

SURFACE ACOUSTIC WAVE FILTER for TV

APPLICATION MANUAL

muRata

*Innovator
in Electronics*

Murata
Manufacturing Co., Ltd.

Introduction

Murata has continued research on surface acoustic wave filters since 1970. In 1976 we offered for sale our first surface acoustic wave filter to be used in the IF of high-fidelity FM tuners. This product attracted the attention of the world, because our surface acoustic wave filter was applied in electronic equipment for consumer use for the first time in the world. Then, we successfully developed and offered for sale the surface acoustic wave filter for the video IF of color television sets. New developments in technology made the television sets smaller in size, which improving their performance year after year. With the discrete circuit integrated to IC, the age has come when most of the circuitry of a television set, with the exception of the power supply and the tuner, is composed of just 4 LSI and a few transistors. Our surface acoustic wave filter for video IF circuits of television succeeded in making the LC filter block into a solid state device previously left behind integration. Murata has recently developed compact, high performance resin mold SIP type package for surface acoustic wave filters.

CONTENTS

1	Terms for Surface Acoustic Wave Filters	2
2	Features	3
3	Fundamentals	4
	3-1. Electrode Pattern Design	4
	3-2. Substrate	5
	3-3. Photolithography	5
	3-4. Sputter	6
	3-5. Assembly	6
	3-6. Electrical Characteristics	7
	3-6-1. Amplitude characteristics	7
	3-6-2. Phase Characteristics	7
	3-6-3. Insertion Loss	8
	3-6-4. Measurement Circuit	9
	3-6-5. Measurement Method	10
4	Application	11
	4-1. Connection of the Surface Acoustic Wave Filter with Other Blocks	11
	4-1-1. Input/Output Impedances of the Respective Blocks	11
	4-1-2. Connection of the Tuner and the VIF Stage	12
	4-2. Application Circuit	14
	4-2-1. Pre-amplifier System	14
	4-2-2. Post-amplifier System	17
	4-2-3. Method for the Compensation of the Insertion Loss without Amplifier	19
5	Appendix	20
	5-1. Two Detection Methods and the Specification of the Surface Acoustic Wave Filter	20
	5-2. TTE and Direct Breakthrough	20
	5-3. Impedance of the Surface Acoustic Wave Filter	22
	5-4. Reliability Test	24
	5-5. Notice (handling)	25

1	Terms for Surface Acoustic Wave Filters
2	Features
3	Fundamentals
4	Application
5	Appendix

1

Terms for Surface Acoustic Wave Filters

● Surface Acoustic Wave (SAW)

An acoustic wave, propagating along a surface of an elastic substrate, whose amplitude decays exponentially with substrate depth.

● Surface Acoustic Wave Filter (SAW Filter)

A filter characterized by a surface acoustic wave which is generated by IDT and propagates along a substrate surface to a receiving IDT.

● SAW Coupling Coefficient

SAW electromechanical coupling coefficient defined by $K_s^2 = 2 |\Delta V/V|$, which means the efficiency to transform electrical energy into acoustic energy or vice versa.

● IDT (Interdigital Transducer)

A comb structure consisting of interleaved metal electrodes whose function is to transform electrical energy into acoustic energy or vice versa by means of the piezoelectric effect.

● Finger

An element of the IDT comb electrode.

● Bus Bar

A common electrode connecting individual fingers together.

● Finger Overlap

The length of a finger pair between which only electromechanical interaction is generated.

● Apodization

Weighting produced by the change of finger overlap.

● Aperture

Maximum IDT finger overlap length

● TTE

Unwanted signals in a SAW filter which has three times traversed the propagation path between input and output IDT's.

● Bulk Wave Signals

Unwanted signals caused by bulk wave excitation, which can be suppressed by grooving the bottom of the substrate.

● Absorber

Surface acoustic wave propagates to the right and to the left because of IDT's symmetrical construction. Silicon rubber is coated on the outer side of IDT's to damp the surface acoustic wave propagates to outer side.

● Feed Through Signals

Unwanted signals from the input appearing at the filter output due to coupling by stray capacitances and other electromagnetic couplings.

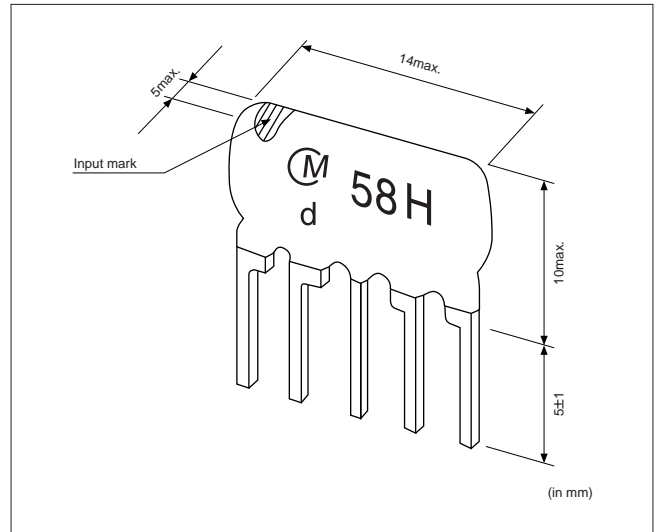

Fig.1 Dimensions

2 Features

- (1) Provides the same characteristics as conventional LC filter block with no adjustment.
- (2) Labor saving for color television VIF circuit assembly line.
- (3) Make the VIF circuit to be compact and integrated.
- (4) Extremely beautiful television pictures possible.
- (5) Temperature coefficient of the trap frequency is small.
- (6) Resin molded type available at low prices.
- (7) Shares very small space on a P.C.B.

3 Fundamentals

3-1. Electrode Pattern Design

The basic configuration of a surface acoustic wave filter is two IDTs on the surface of the piezoelectric substrate. The first IDT connected to the signal source generates a surface acoustic wave, which propagates along a substrate surface to the second IDT, which transforms SAW energy into electrical voltage on a load connected to the IDT. Frequency characteristics of the IDTs can be calculated by means of impulse model. In case of Normal IDT which has a constant pitch and a constant overlap, the IDT and the corresponding impulse is shown in Fig.2 below. When a voltage is fed to the IDT, the direction of the voltage is the positive-negative-positive-negative direction at $\lambda/2$ interval. The voltage is then subjected to expansion and shrinkage of substrate by the piezoelectric effect. One impulse pair of adjacent positive and negative polarities is correspond to one electrode pair.

When the wavelength of the surface acoustic waves generated by each impulse is equal to the electrode pitch λ_0 , we get maximum SAW energy. Wave velocity is V , electrode pitch is λ_0 , number of electrode pair is N , then frequency characteristics of normal IDT can be calculated by the equations shown below.

$$A(f) = \frac{\sin N\pi X}{N\pi X} \quad \text{where } X = \frac{f - f_0}{f_0}, \quad f_0 = \frac{V}{\lambda_0}$$

Frequency characteristics can be changed easily by means of weighting. There are two mainly used weighting method.

- (a) Varying the Finger Overlap (magnitude of impulse), called "apodize".
- (b) Varying pitch (position of impulse), called "variable pitch."

Assuming that impulse of magnitude a_i including signs is at the time t_i , the summation of waves is given by the equations shown below. This represents the Fourier transformation itself. Since the impulse is uniquely determined when electrode pattern is given, frequency characteristics are determined by applying the Fourier Transformation. Optimum pattern that correctly meet any specification is designed by means of computer simulation.

$$F(f) = \sum_{i=1}^N a_i e^{-j2\pi f t_i}$$

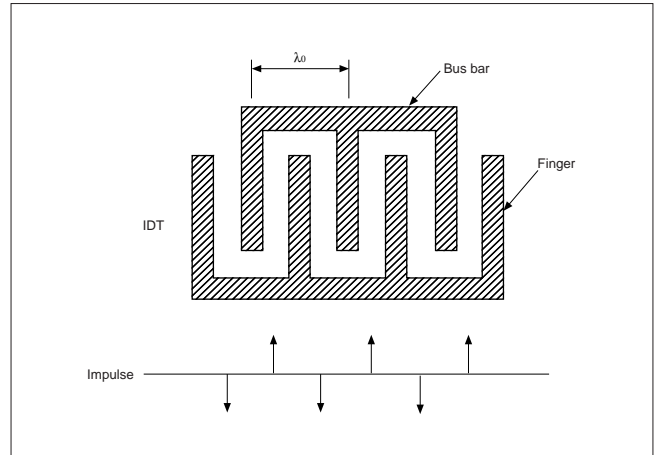

Fig.2 IDT and the corresponding impulse

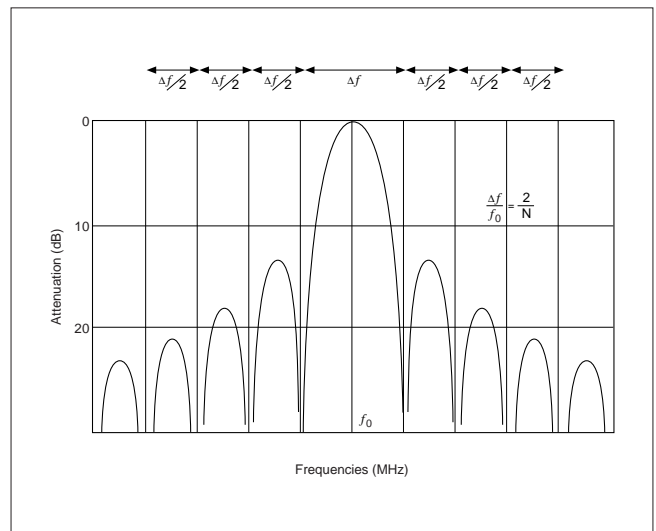

Fig.3 Frequency characteristics of the normal IDT

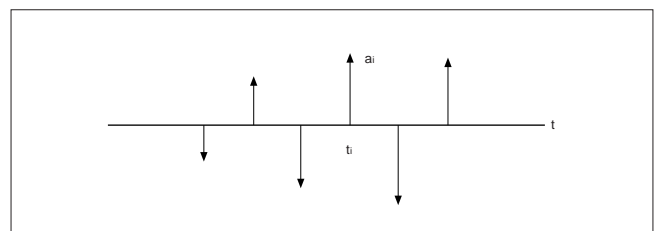

Fig.4 Weighted impulse

3-2. Substrate

ZnO, and single crystal are usually used as substrate materials for the surface acoustic wave filters. Substrates specifically available for the surface acoustic wave filter for color television sets should satisfy the following conditions:

- (1) The surface acoustic wave electromechanical coupling coefficient k_s is large.
- (2) The effective dielectric constant is proper.
- (3) Propagation velocity has a small temperature coefficient.
- (4) Propagation loss of the surface wave is small.
- (5) Stable against heat and little change by aging.
- (6) Cost of producing the substrate is low.
- (7) The material constants in/between substrates have little dispersion.

The characteristics (1) through (4) refer to the electric properties of the surface acoustic wave filter, (5) refer to the reliability, and (6) and (7) refer to the price of the product. The larger the electromechanical coupling coefficient k_s mentioned in (1), the smaller the insertion loss of the surface acoustic wave filter. On the other hand, the dielectric constant of the substrate is related to the impedance of the surface acoustic wave filter. The temperature coefficient of the propagation velocity mentioned in (3) determines the temperature coefficient of the center frequency of the filter. Presently, there is no substrate fulfilling all the requirements listed above, and the available materials have both advantages and disadvantages. Since surface acoustic wave filter for color television needs a relatively large substrate size, substrate material cost should be as low as possible. Using well established ZnO sputter techniques, Murata provides high performance substrates at very low cost. Single crystal substrates are relatively expensive despite good reproducibility and stability.

Substrate materials	Crystal Cut	Propagating Direction	SAW Velocity (m/sec.)	k_s^2 (%)	Temperature Coefficient (ppm/°C)	Dielectric Constant
LiNbO ₃	128° Rotated Y	X	3994	5.6	-74	38
LiTaO ₃	X	112°Y	3296	0.7	-18	51
ZnO/glass*	—	—	2600	1.0	-28	8.5

* Non-alkaline glass

Table 1 Properties of substrate materials for surface acoustic wave filters

3-3. Photolithography

This is a technique for forming fine electrodes on the substrate. Process is producing photomasks based on the designed data, coating resist onto the aluminum evaporated substrate, on which the photomask is set and radiating ultraviolet rays onto the photomask and forming IDT by etching unwanted aluminum. Surface acoustic wave filter treating 58MHz of the television VIF frequency has more than 100 fine finger electrodes, of which width is about 6 micrometers. Surface acoustic wave filters are being manufactured by fully automated production line at strictly environmental controlled room, for fear of disconnection and shorting by dust.

3 Fundamentals

3-4. Sputter

For the purpose of getting piezoelectric thin film on glass, ZnO must be deposited on glass substrate by sputtering. A simplified sputtering apparatus is shown in Fig.5. First, berzia is pumped to high vacuum, then low pressure argon and oxygen gas flow. Then, a high frequency voltage is fed to ZnO ceramic target (cathode) so that the argon gas is ionized. Ionized argon goes to target, makes the target composing element of ZnO sputtered out. These are eventually coated onto the IDT portions of the glass substrate. Murata has established a stable technique that can produce high performance ZnO thin film with high deposition rate and low variation of C axis orientation.

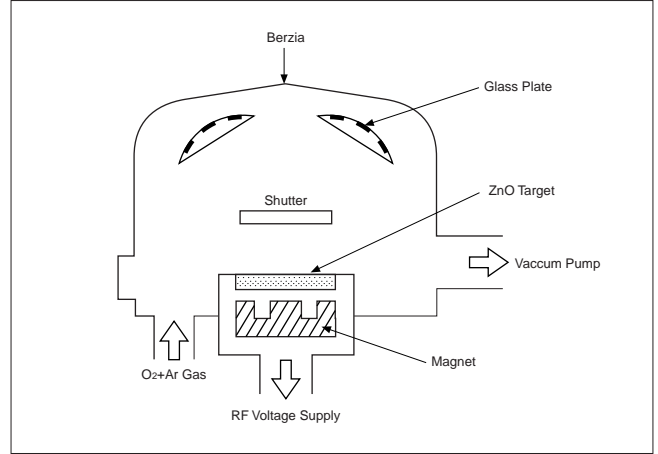

Fig.5 Sputtering apparatus

3-5. Assembly

Lead is soldered directly to the substrate as shown in Fig.6 below, thus providing a strong and steady connection. This connection has no danger of lead wire breaking caused by vibration and corrosion caused by humidity as conventional wire bonding connection. Resin mold and caves on the surface of the substrate are formed by the processes described below. First, wax is coated on the IDT electrodes of element. Then the element is coated with resin by dipping. When resin is cured, the wax is melted by heat and is absorbed into the resin via capillary phenomena, while caves are formed on the surface of the substrate. The first layer of external resin is low expansion coefficient resin used for Murata's FM CERAFIL®. The second layer is moisture-resistant precise resin. (SAFGH Type)

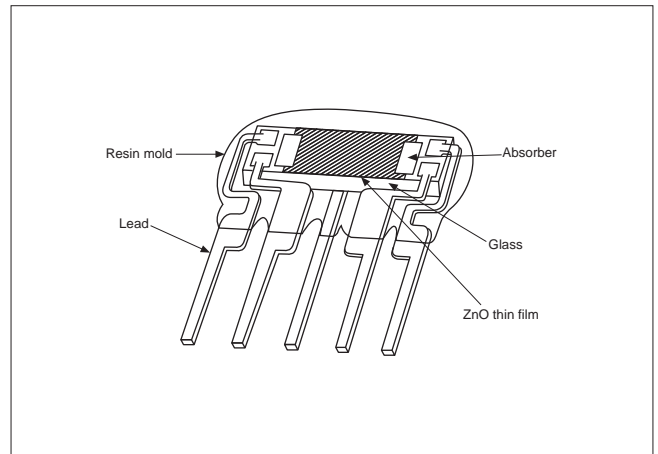

Fig.6 Construction of the SAW filter (SAFGH Type)

3-6. Electrical Characteristics

3-6-1. Amplitude characteristics

Fig.7 shows the characteristics of the surface acoustic wave filter for the television VIF circuit. Being remarkably different from conventional LC filters, the SAW filter has a response of many peaks and bottoms outside the pass band. It is necessary to add the items of spurious attenuation of upper side and lower side.

3-6-2. Phase Characteristics

In the case of surface acoustic wave filters, the output signal has a delay with regard to the input signal, corresponding to the time of propagation from input IDT to output IDT of the surface acoustic wave. For example, when a thin film of ZnO sputtered on glass is used as piezoelectric substrate, the propagation velocity of the surface acoustic wave is approximately 2600m/sec. If the distance between the input and output IDT is 3mm, the propagation time of the surface acoustic wave will be approximately 1.2 μ sec. Since the delay time of the surface acoustic wave filter is relatively large as shown above, the gradient of the phase with regard to the frequency is large, and as a result, it is hard to observe the phase linearity by measuring its phase characteristic. In view of these facts, it is more convenient to observe the variations of the group delay time.

SAFGN58M7VH0Z00B03 (shown in Fig.7) is designed by properly compensating for the group delay time via the chroma bands. Since the short cycle ripple of the group delay time critically affect the performance of these filters, it is sometimes included in the specifications of the filter. In this case, ripple is defined as the maximum value of the difference between neighbouring peak and valley. The ripple is chiefly caused by the TTE (Triple Transit Echo) in most cases, but it may also be caused by the direct breakthrough.

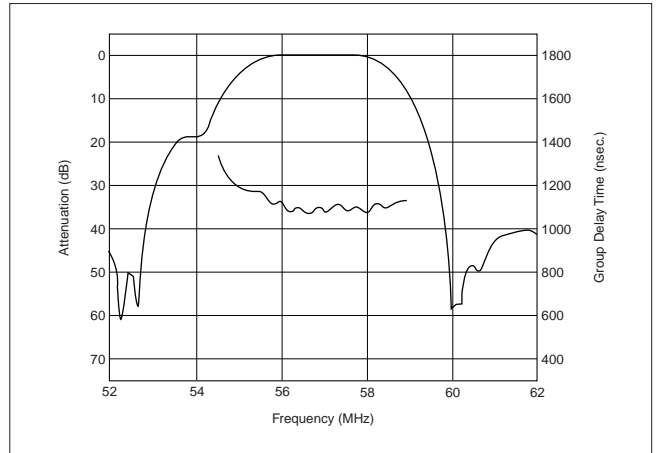

Fig.7 Frequency characteristics of SAFGN58M7VH0Z00B03

3 Fundamentals

3-6-3. Insertion Loss

As terms to express loss there are insertion loss and power loss. In some cases there is confusion regarding these two terms, but here we introduce one term more, i.e., voltage loss, and make a clear distinction between the definitions of each term as follows; In Fig.8 (a) V_s is the signal source voltage, V_L is the output voltage, R_s is the signal source impedance, and R_L is the load impedance. The insertion loss is defined as the ratio of the output voltage V_L when filter is removed and short circuited by jumper wire, as shown in Fig.8 (b), to the maximum output voltage when filter is inserted. In this case, attention should be paid to the fact that the insertion loss is not the ratio of the signal source voltage V_s to the output voltage V_L . Even when the ratio of V_s to V_L is constant, the insertion loss can be changed when the ratio of R_s to R_L is changed. In this brochure the ratio of the signal source voltage V_s to the output voltage V_L , i.e., $20 \log (V_s/V_L)$ is defined as voltage loss. From the considerations presented above, the following relation can be obtained:

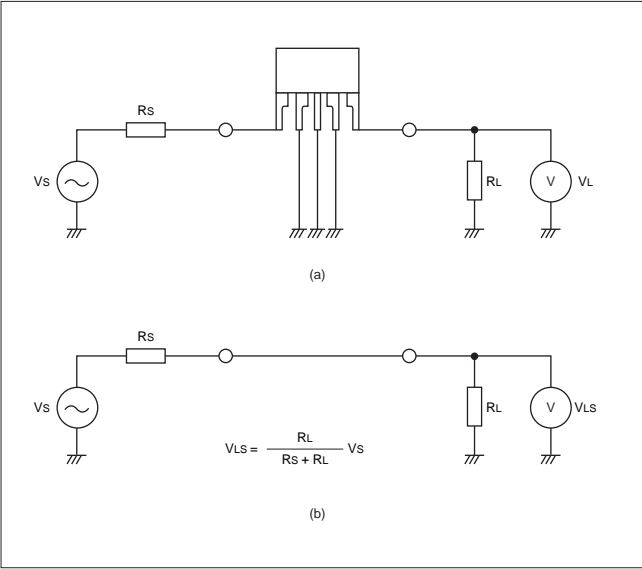

Fig.8 Effect of power dissipation by incorrect insertion of SAW filter

$$\text{Insertion loss} = \text{Voltage loss} - 20 \log \frac{R_s + R_L}{R_L} \dots\dots (1)$$

Power loss is defined as the ratio of the available power of the signal source and the power supplied of the load as follows:

$$\begin{aligned} \text{Power loss} &= 10 \log (V_s^2/4R_s) / (V_L^2/R_L) \\ &= 20 \log (V_s/V_L) + 10 \log (R_L/4R_s) \end{aligned}$$

Thus,

$$\text{Power loss} = \text{Voltage loss} + 10 \log (R_L/4R_s) \dots\dots\dots (2)$$

From (1) and (2) we obtain the following relation:

$$\text{Power loss} = \text{Insertion loss} + 10 \log (R_s + R_L)^2 / 4R_sR_L \dots\dots\dots (3)$$

From (3) it is possible to see that when $R_s = R_L$, we have:

$$\text{Power loss} = \text{Insertion loss}$$

The following considerations are developed based upon the definitions above. The power loss of a SAW filter is determined by the relation of the impedance of the filter itself and the terminating impedances at input and output sides. Close to the center frequency of the SAW filter, the input and output impedances of the filter itself is expressed as a capacitance and a resistance in parallel. This resistance is called radiation resistance, and the power consumed by this resistance becomes the surface wave energy. Thus, the power loss can be reduced by performing an effective consumption of power by this radiation resistance. When the signal source impedance R_s and the load impedance R_L are

purely resistive, assuming R_s is equal to the absolute value of the input impedance Z_{in} of the SAW filter, and R_L is equal to the absolute value of the output impedance Z_{out} of the SAW filter, the power loss becomes minimum.^(*)

^(*) Strictly speaking, the condition for minimum power loss slightly differs from the condition $R_s = |Z_{in}|$, $R_L = |Z_{out}|$

Since Z_{in} and Z_{out} have capacitive components, the power loss can be further decreased by performing the cancellation of these capacitive components by means of inductance, and matching the remaining pure resistive components with R_s and R_L . In this case the power loss is actually minimized thanks to the conjugate impedance matching. As described above, the power loss can be reduced by means of the impedance matching of the input/output impedances of the SAW filter, but it is known that the level of the TTE (Triple Transit Echo) and the power loss are in conflicting relation, i.e., when the power loss is reduced the TTE increases. A required suppression of the TTE in cases of practical use is -40dB, and in order to attain that value, it is said theoretically that the power loss of the SAW filter should be larger than 16dB. Thus, in cases of practical application, instead of matching perfectly, the SAW filter is mismatched to some extent, with a power loss larger than 16dB (in order to make possible a certain margin of safety, the actual value of the power loss should be larger than 18dB).

3-6-4. Measurement Circuit

Fig.9 shows measuring circuit of SAFGN58M7VH0Z00B03. To reduce the power loss, parallel tuning coil is used. Since the insertion loss of SAW filters is large, output signal becomes low. And feed through signals make the accurate measurement difficult, requiring attention to the shielding of the test fixture.

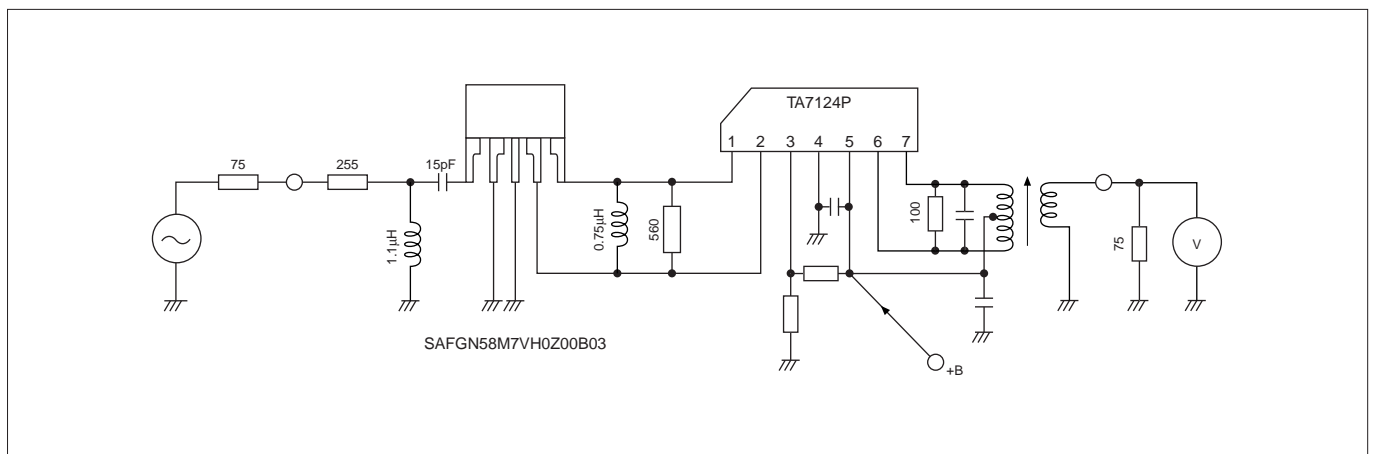

Fig.9 Measuring Circuit

3 Fundamentals

3-6-5. Measurement Method

• Measurement by means of network analyzer

Amplitude and phase, group delay time characteristics can be measured directly by means of the RF network analyzer. Network analyzer for this use is made by several makers. Surface acoustic wave filter for video IF of television sets has many specified points. Murata adopted the synthesizer type programmable network analyzer, which measures quickly and accurately, judges of go or no go for the specifications automatically.

• Measurements in the time domain

The measurement system used to verify the spurious levels of the TTE, etc., is shown in Fig.10. Typical pulse responses are shown in Fig.11. Pulse rise time should be optimally long, because "ears" may appear in the response waveforms due to the band limitations of the filter which disturbs measuring.

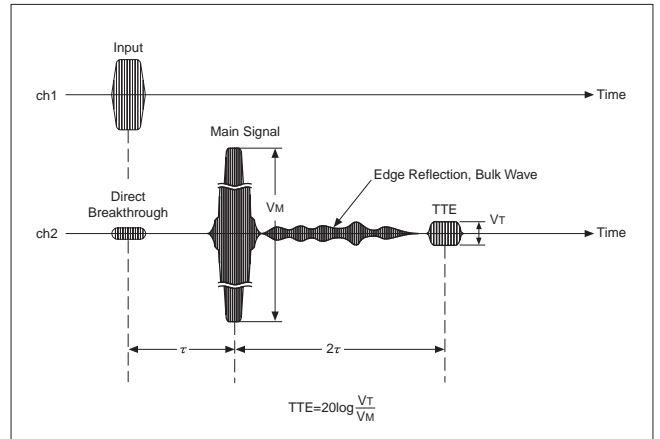

Fig11 Typical Pulse Response Waveform

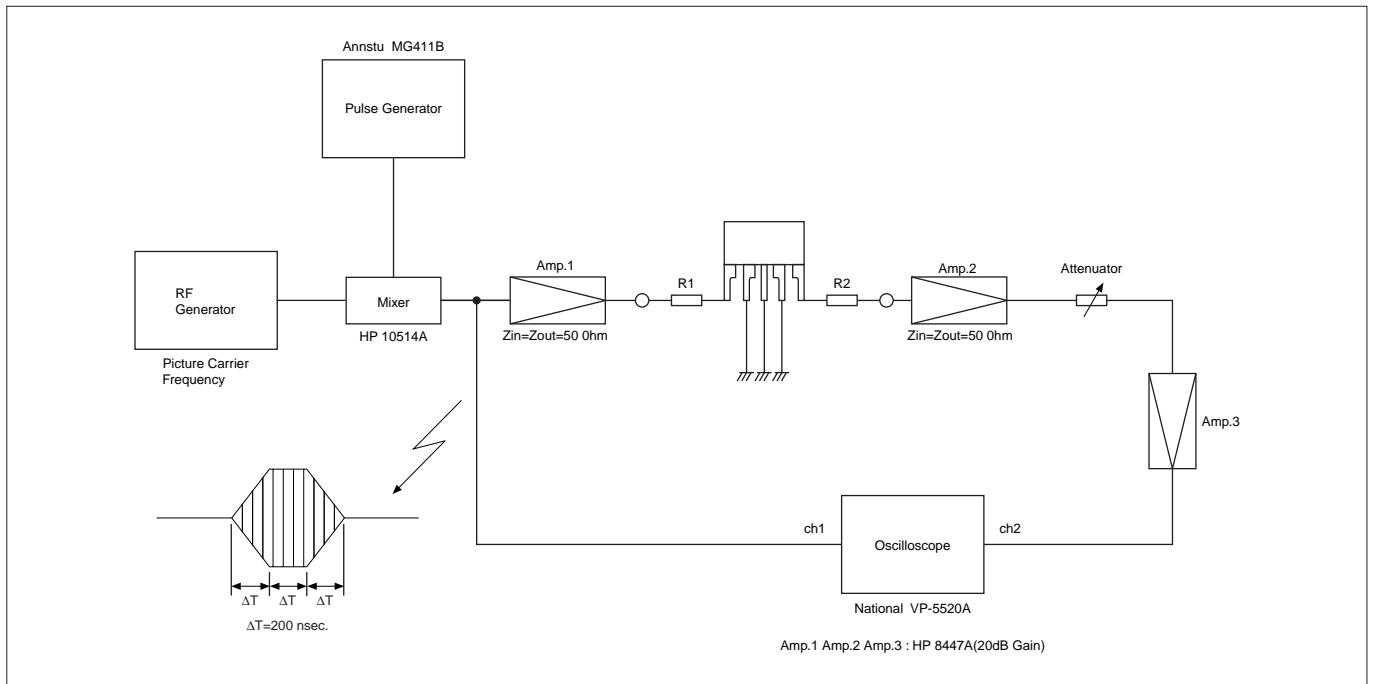

Fig.10 Block Diagram of Pulse Response Measurement System

4 Application

4-1. Connection of the Surface Acoustic Wave Filter with Other Blocks

4-1-1. Input/Output Impedances of the Respective Blocks

The most common method to compensate the high insertion loss of the SAW filter is putting an amplifier. In this case, the connection of the four stages listed below becomes very important in order to use the SAW filter perfectly.

- (1) Tuner
- (2) SAW filter
- (3) Amplifier for compensation of the insertion loss
- (4) One chip IC for color television VIF stage.

As described before, the characteristics of the SAW filter (especially the insertion loss and TTE) are influenced by impedance matching. In order to connect the SAW filter to the stages before and after, we must cleverly consider the facts described above. For the first time we will calculate the impedance of the each stage.

(1) Tuner

Since most of the tuners use coaxial cable, their nominal output impedance is 75Ω (50Ω). On the other hand, as a consequence of the popularization of the electronic tuner, which is sometimes connected to the VIF Stage directly without coaxial cable by mounting the UHF and VHF tuner on the main PCB of the television set. In this case the tuner can be designed to have a high output impedance.

(2) SAW Filter

The input and output impedances of the SAW filter are determined by piezoelectric substrate material mainly. As described previously, the equivalent circuit of the SAW filter is expressed by a resistance and a capacitance in parallel or in series (Fig.12). Table (2) presents the results of actual measurements performed with SAW filters manufactured by us. Since the capacitance C_p is cancelled when parallel coil is put, the impedance of the SAW filter (including the coil in parallel) at the center frequency is given by R_p . In this case the value of the impedance becomes larger than the value of no tuning impedance R_p/C_p . When series coil is put, parallel expression of Fig.12 (a) should be changed into the series expression of Fig.12 (b). Since in this case the tuning coil and C_s are in series resonance, the impedance of the SAW filter (including the tuning coil) becomes equal to R_s . This value is smaller than the impedance of the filter without tuning coil (R_p/C_p).

(3) Amplifier for compensation of the insertion loss.

Amplifier for compensation of insertion loss is composed of a discrete bipolar transistor, for its low cost. Now, we assume that the amplifier has the configuration mentioned above. Used with emitter grounding, the amplifier will have a low input impedance, of the order of 50Ω to 100Ω . The output impedance depends upon the resistor connected to the collector, but if this resistor has a small value the gain of the amplifier is reduced,

		SAFGN58M7 VH0Z00B03	SAFGN45M7 VA0Z00B03	SAFGN38M9 VZ0Z00B03
Input	Rpi	2.1k Ω	4.9k Ω	17k Ω
	Cpi	8.1pF	6.8pF	4.7pF
	Rsi	57 Ω	58 Ω	53 Ω
	Csi	8.4pF	6.9pF	4.7pF
Output	Rpo	1.7k Ω	4.0k Ω	11k Ω
	Cpo	6.2pF	5.0pF	3.3pF
	Rso	110 Ω	130 Ω	150 Ω
	Cso	6.6pF	5.2pF	3.4pF

Table 2 Equivalent Circuit Constants of SAW filters

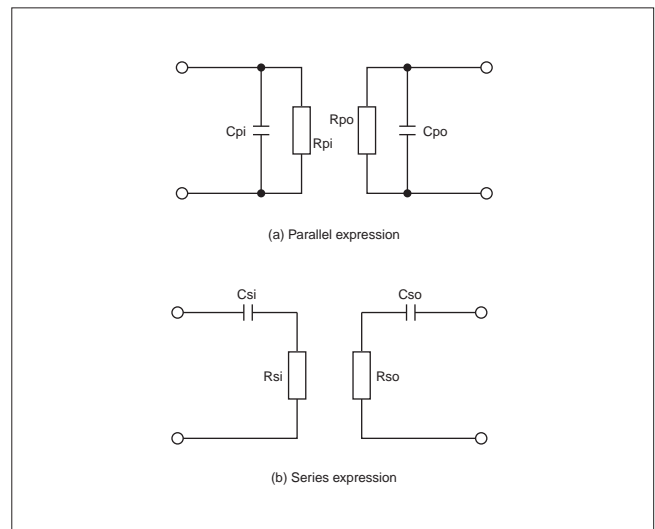

Fig.12 Equivalent Circuits of the Surface Acoustic Wave Filter

4 Application

and if it is a large value, the output impedance of the transistor itself will be upper limit. Thus, it is of the order of 100Ω to $1\text{ k}\Omega$ is useful.

(4) One chip IC for VIF

The input impedance of the one chip IC for television VIF is of the order of $1\text{ k}\Omega$ to $3\text{ k}\Omega$.

4-1-2. Connection of the Tuner and the VIF Stage

When using the SAW filter, the importance of its relation with the impedances of the stages located after and before the SAW filter was already described. In addition, the connection between the tuner and the next stages requires special attention. As shown in Fig.13,

there are many types of IF output circuits of the tuner. The most commonly used circuit is that shown in (a), but the double tuning system of (b) and (c), and the cascade circuit of (d) and (e) are also used. The IF output frequency characteristics of the tuner depend upon the circuit used. The overall frequency characteristic of the television set is determined by the combination of the frequency characteristic of the tuner IF output stage and the frequency characteristic of the SAW filter. Thus, even when the overall characteristic of the VIF stage of the television set is known, the required frequency characteristic of the SAW filter can be changed if the IF characteristic of the tuner, used together with the SAW filter, is changed. In other words, if there is a SAW filter with a given characteristic, it is necessary to connect with a tuner presenting characteristics conveniently matched with the SAW filter. For example, to combine a VIF stage to a tuner with single tuning IF output circuit, in some cases, it is required to make a resonant circuit between the IF output circuit of the tuner and input circuit of the VIF stage, as shown in Fig.14, virtually performing a double tuning circuit. In this case, if the LC of the VIF stage is removed and replaced by a SAW filter, the circuit will be a single tuning one, and as a result the overall bandwidth may become narrower. When the overall bandwidth is narrow, the most simple solution is the use of the resistor in parallel with the input of the VIF stage to damp the Q of the circuit to widen the IF output bandwidth. However, this action makes the voltage level to be reduced, it is recommended to change the tuner with another one to have a wider bandwidth. In order to increase the bandwidth of the IF output stage, one must adopt the double tuning as shown in Fig.13 (b), (c) or damp the Q of the circuit by means of damping resistor, as shown in (d) and (e) a cascade circuit is used for fear of gain reduction due to the Q-damping and also to improve the stability of the circuit. On the other hand, in circuits like that shown in (a), it is possible to widen the bandwidth by changing the circuit constant, as shown in (a'). The nominal output impedance of the tuner is 75Ω , but in actual cases it often has strong frequency dependence as shown in

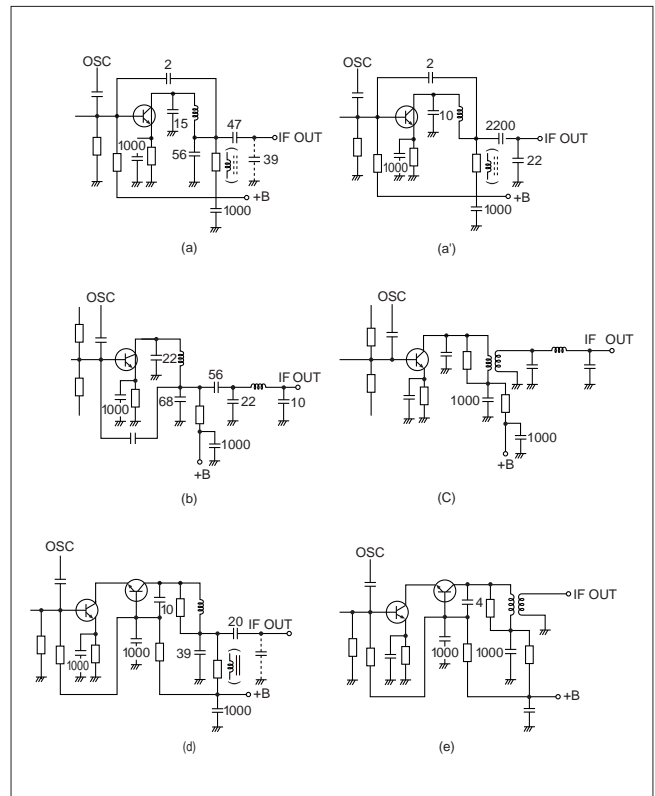

Fig.13 Various Types of IF Output Circuit of the Tuner

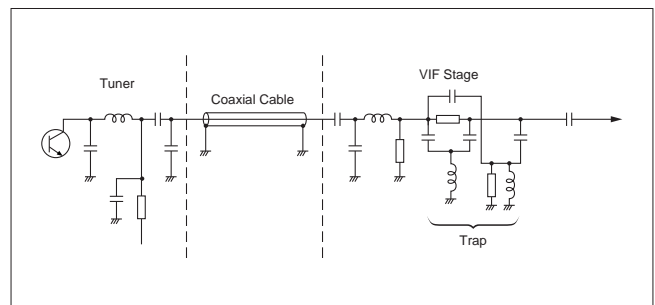

Fig.14

Application 4

Fig.15. Figure 15 (a) corresponds to the Fig.13 (a) with the popular π type circuit, and Fig.15 (b) corresponds to the Fig.13 (b) with the double tuning circuit. Fig.15 (c) corresponds to the case of Fig.13 (a'), and in this circuit the output impedance has a very weak frequency dependence. Connecting the tuner output to the SAW filter directly (for example, the case of the post amplifier system described later), the strong frequency dependence of the tuner output impedance may be difficult problem. Reactance of tuner output changing frequency to frequency will change the tuning state of SAW filter to make the shape of amplitude characteristics of the SAW filter change from its own one. Thus, in the post-amplifier system it is desirable to use a tuner with nearly constant output impedance, as shown in Fig.15 (c). On the other hand, in the preamplifier system described later, output impedance changing of the tuner is not so difficult problem, being sufficient to consider only the bandwidth of the IF output stage. In other words, since the preamplifier plays the role of a buffer, the SAW filter connected after it is not influenced by the tuner output impedance.

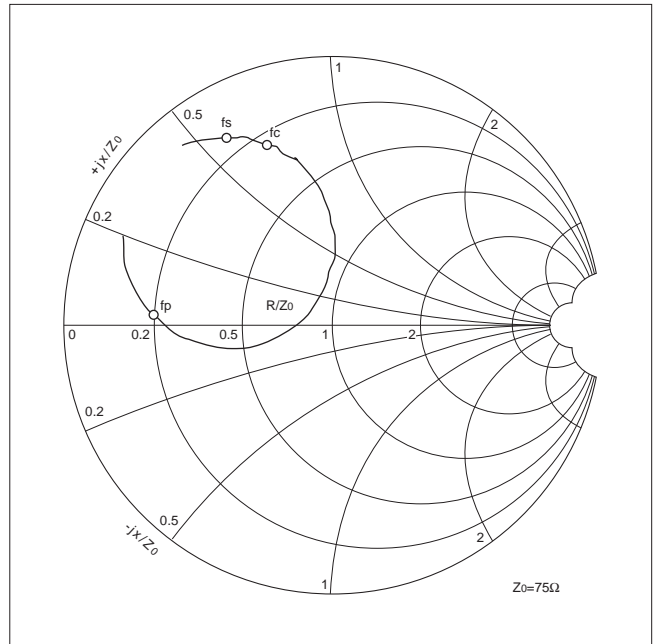

Fig.15 (a) IF Output Impedance of the Tuner

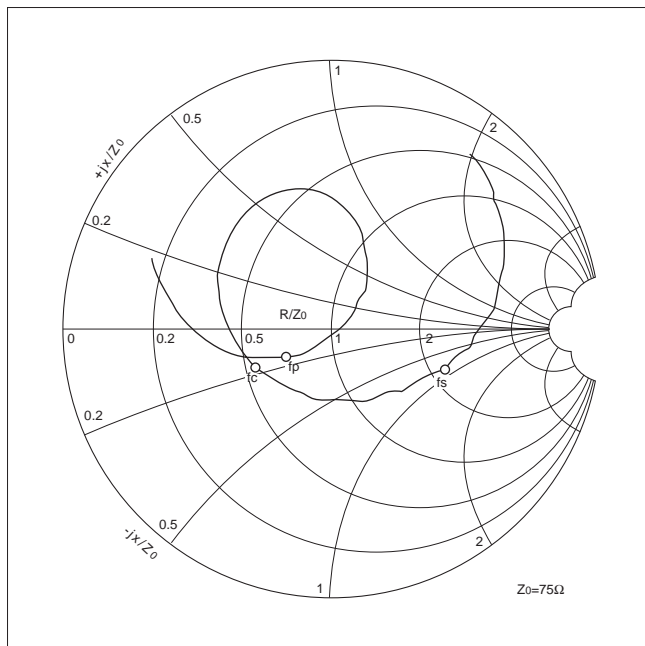

Fig.15 (b) IF Output Impedance of the Tuner

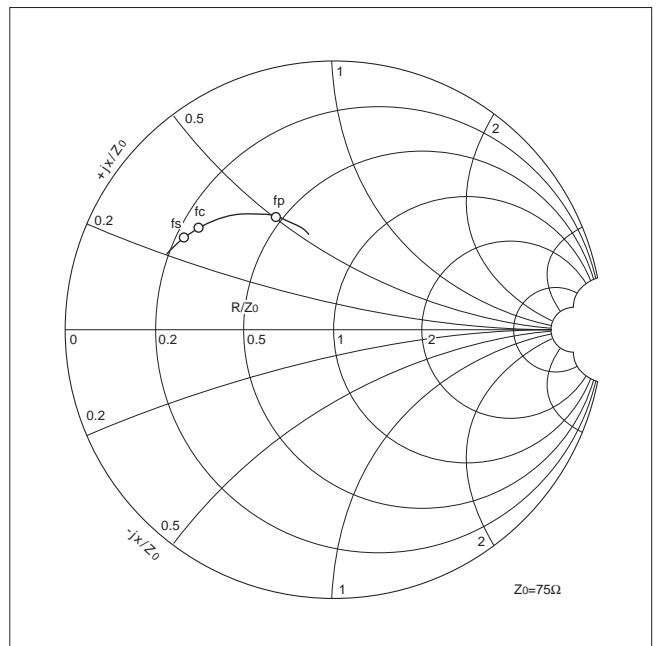

Fig.15 (c) IF Output Impedance of the Tuner

4 Application

4-2. Application Circuit

4-2-1. Preamplifier System

● Preamplifier system

The system where the insertion loss compensation amplifier is placed before the SAW filter is called a preamplifier system. Fig.16 (a) is an example of a preamplifier system, and it can be converted into the configuration shown in Fig.16 (b) in AC operation. The value of R_s shown in Fig.16 (b) can be controlled by changing the value of R_1 . On the other hand, R_L can also be controlled by changing the value of R_2 . As described previously, the insertion loss of the SAW filter depends upon the impedance matching. To make the external terminating impedance equal to the impedance of the SAW filter (impedance of the SAW filter including the tuning coil, when such a coil is used), gets minimum insertion loss. But SAW filter should be mismatched in order to suppress the TTE. When in no tuning and in parallel tuning, making the terminating impedance to be mismatched to the lower side makes TTE reduced (so that the ripple on the group delay time characteristic is reduced as shown in Fig.17). On the contrary, the mismatching to the higher side makes TTE increase. Too small R_s and R_L bring high power loss, the values of R_s and R_L must be determined with making compromise between the TTE suppression and the voltage gain. In the case of series coil tuning the situation is inverse. As shown in Fig.18, when the external terminating impedance is mismatched to the higher side, the TTE reduces.

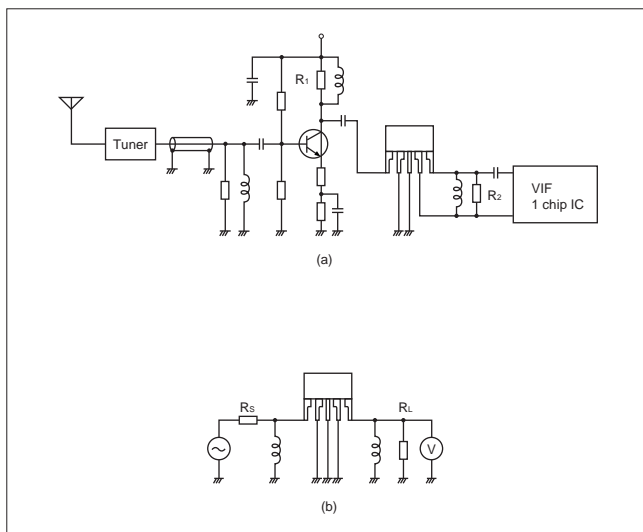

Fig.16 Preamplifier System

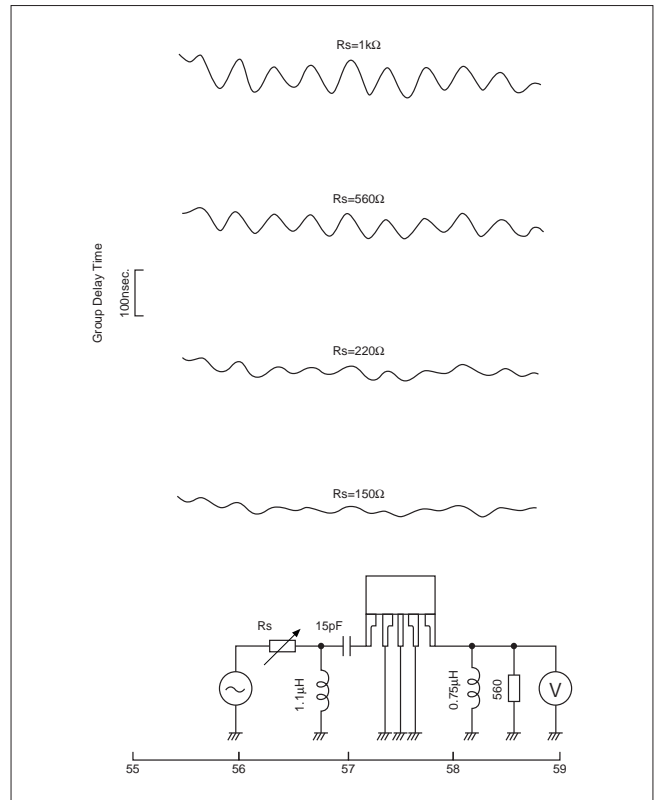

Fig.17 Relation between the Terminating Impedance and the Ripple of the Group Delay Time Characteristic (Parallel tuning)

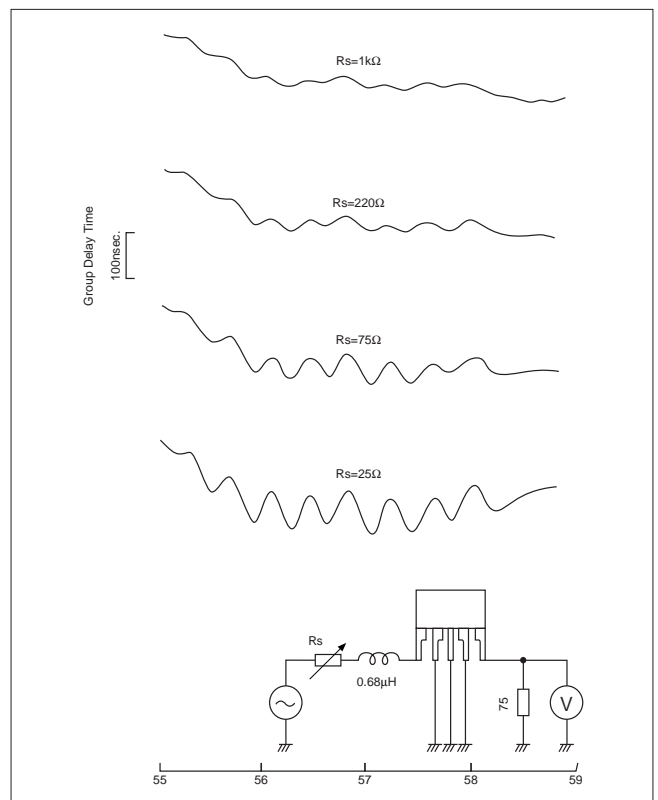

Fig.18 Relation between the Terminating Impedance and the Ripple of the Group Delay Time Characteristic (Series Tuning)

Application 4

● Considerations referring to the gain in the preamplifier system.

In Fig.20, since capacitance of the SAW filter, transistor and VIF IC can be cancelled by means of the coil connected in parallel, only the resistive component may be taken into consideration. The simplified equivalent circuit of Fig.19 will have the final configuration shown in Fig.20. The circuit shown in Fig.20, is considered equivalent to the actual working state of Fig.19. The last circuit is used as test circuit. In Fig.20 the voltage gain G between the input and the output is expressed as:

$$G = 20 \log (e_0/e_i) \dots\dots\dots (1)$$

Assuming insertion loss of SAW filter is L (dB) ($L > 0$), and output voltage when $L = 0$ is E_0 (equivalent to the situation with the filter removed and short circuited by the jumper wires), the following relation is valid:

$$E_0 = e_i \cdot gm \cdot R_s \cdot R_L / (R_s + R_L) \dots\dots\dots (2)$$

Thus, from the definition of the insertion loss in 3-6 we have:

$$G = 20 \log (e_0/e_i) = 20 \log (E_0/e_i) - L$$

$$= 20 \log (gm \cdot R_s \cdot R_L / (R_s + R_L)) - L \dots\dots\dots (3)$$

Assuming the power loss of the SAW filter is K (dB), the equations 3-6-3, (3) give the following equation.

$$G = 20 \log (gm \cdot R_s) + 10 \log (R_L/4R_s) - K \dots\dots\dots (4)$$

In order to increase the value of G , the values of $20 \log (gm \cdot R_s)$ and $10 \log (R_L/4R_s)$ should increase and the value of K should be reduced. However, K should be more than 16 or 18 dB in order to suppress the TTE. $20 \log (gm \cdot R_s)$ is the voltage gain of the preamplifier, gm depends upon collector current of the transistor. When the source voltage is given, the maximum output level is determined as a consequence of linearity of the amplifier, and thus, in actual cases the voltage gain of the preamplifier can be considered constant.

Consequently, only $10 \log (R_L/4R_s)$ remains undetermined. R_L/R_s should be as large as possible, (a power loss of the order of 16 - 18 dB). For example, if the power loss K of the SAW filter is assumed as 16dB (constant), the total voltage gain and R_L/R_s will present the relation shown in Fig.21. Fig.21 shows that when the gain of the preamplifier is constant, the total gain increases with the ratio R_L/R_s .

● Cautions for preamplifier system

Since the signals of the preamplifier are amplified to high levels, it is necessary to prevent distortions due to the intermodulation. To insert resistance of negative feed back on emitter is commonly used. The preamplifier system is suited for high impedance SAW filters. Using a low impedance SAW filter with the preamplifier system, the values of R_s and R_L shown in Fig.20 will be very low for fear of TTE, and as a result the gain of the preamplifier, $20 \log (gm \cdot R_s)$ is reduced. In the preceding chapter, R_s change could be

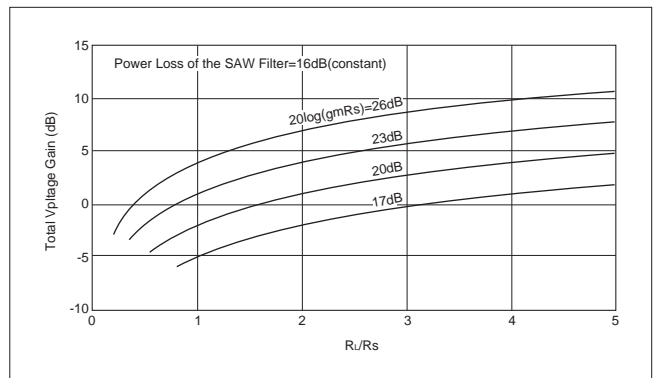
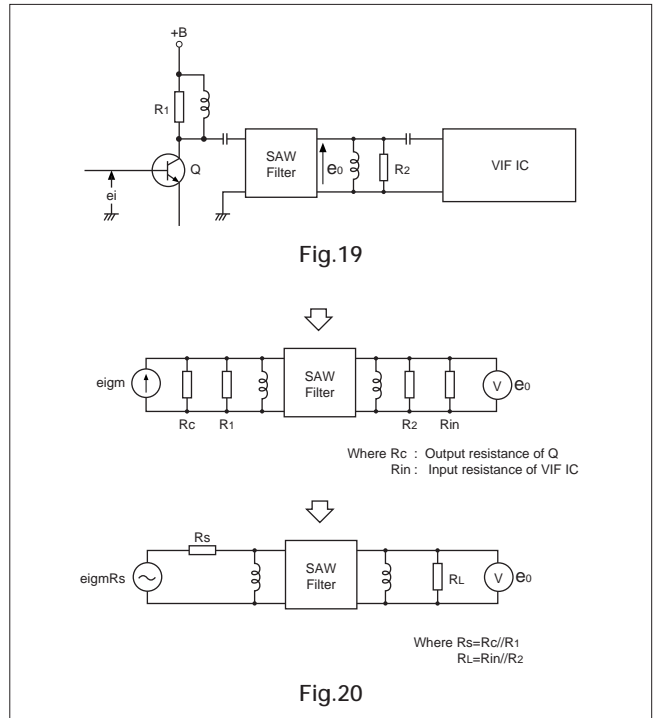

Fig.21 Relation between the Total Voltage Gain and R_L/R_s

4

4 Application

compensated for by changing gm as a result of changing the collector current, resulting therefore in a constant value of $20 \log (gm \cdot R_s)$. However, when the value of R_s is too small, the collector current is limited by its maximum collector dissipation, gm are not become so high. Consequently it is not possible to compensate the reduction of R_s . In using low impedance SAW filters in the preamplifier system, the following modifications are required.

- Use of the low impedance SAW filter in the preamplifier system.

An impedance conversion circuit is required for the use of a low impedance SAW filter in the preamplifier system. Fig.22 shows an example of use of a low impedance SAW filter in the preamplifier system. A well-known impedance conversion circuit using transformer tap down shown in Fig.23 (a) can be modified to the circuit shown in Fig.23 (b), with capacitance tap down, the capacitance of the SAW filter in Fig.22 corresponds to the capacitance C_2 of Fig.23 (b). The coil plays a part of transformer as well as a tuning coil. In Fig.23 (b) the equivalent transformation ratio is given by $C_1 : (C_1 + C_2)$, and the impedance ratio is given by $C_1^2 : (C_1 + C_2)^2$. Thus, an arbitrary impedance transformation can be attained by selecting a convenient value of C_1 . In the circuit in Fig.22, the impedance at the input side of the SAW filter can be reduced by stepping-down, and at the output side the impedance can be increased by stepping-up. Thus, in this case it is possible to use a low impedance SAW filter with the same peripheral circuit used in the case of a high impedance SAW filter.

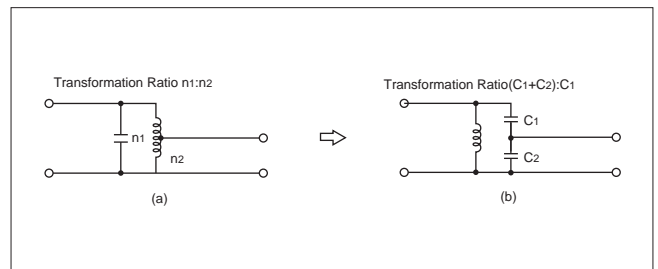

Fig.23 Transformation Circuits

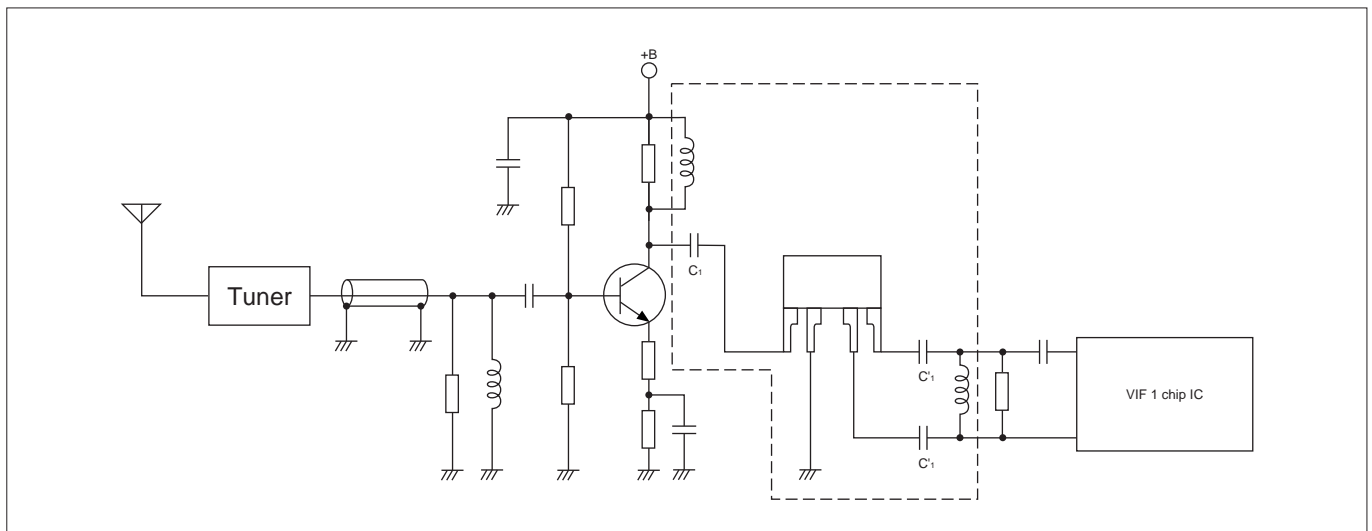

Fig.22 A Circuit Using a Low-impedance SAW Filter in the Preamplifier System

Application 4

4-2-2. Postamplifier System

• Postamplifier system

The system using the amplifier for compensation of the insertion loss after the SAW filter is called postamplifier system. Fig.24 shows an example of postamplifier system. If the postamplifier is composed of an emitter grounded bipolar transistor, the input impedance will have a value of the order of 50 to 100Ω. Usually the output impedance of the tuner has a nominal value of 75Ω. The external terminating impedances of the postamplifier system can not be changed so easily as the preamplifier system. When both input and output of the high impedance SAW filter are terminated by 75Ω, the mismatching rate is too much, resulting in large insertion loss, it is necessary to modify the circuit as described below section. When low impedance SAW filter is terminated by 75Ω, both the TTE suppression and the insertion loss can be arranged at a suitable value. However, since the input impedance of the SAW filter seen from the tuner is not perfectly 75Ω, the frequency characteristic of the IF output stage of tuner is sometimes influenced by SAW filter impedance. For example, if the input impedance of the SAW filter is larger than 75Ω, the Q factor of the IF output circuit of the tuner becomes high, and as a result the bandwidth may become narrower. To prevent this, it is necessary to insert a Q damping resistor in parallel with the input terminals of the SAW filter.

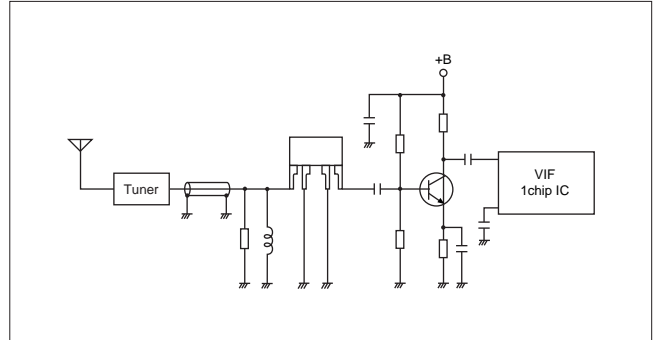

Fig.24

• Considerations about the relation between the power loss of a SAW filter and the noise figure of the postamplifier system

In the postamplifier system, for reason of the low signal level after the SAW filter, they suspect a deterioration in the noise figure. The noise figure of the block diagram shown in Fig.25 should be discussed. Here, in order to simplify the discussion, the SAW filter is assumed as an attenuator with gain G_f . Assuming that only thermal noise is generated, and that both the tuner and the SAW filter have the same bandwidth B , the noise figure F_f of the SAW filter will be expressed as follows:

$$F_f = \frac{(\text{Sin}/k_B T B)}{(\text{Sout}/N_{\text{out}})} = \frac{(\text{Sin}/k_B T B)}{\left(\frac{G_f \cdot \text{Sin}}{(1+G_f)k_B T B} \right)} = 1 + \frac{1}{G_f}$$

Where k_B is Boltzman's constant, T is the absolute temperature of the filter, B is the bandwidth and N_{out} is the output noise level. The noise figure of this system will be given by:

$$F = F_t + \frac{F_f - 1}{G_t} + \frac{F_a - 1}{G_t G_f} + \frac{F_v - 1}{G_t G_f G_a}$$

Fig.26 shows the relation between the power loss of the SAW filter and the noise figure of the total system, with

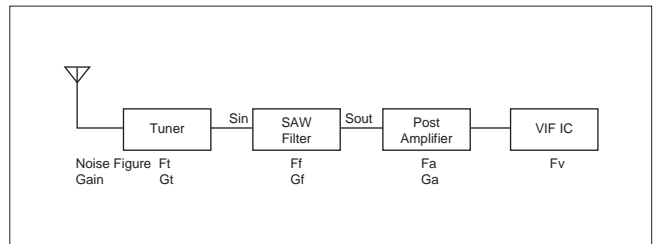

Fig.25

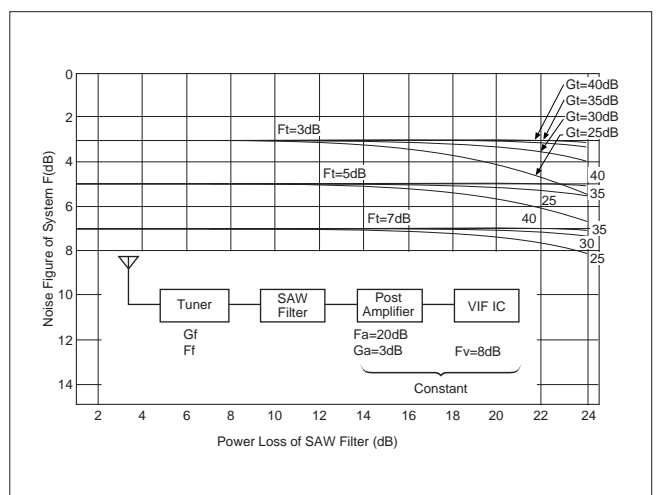

Fig.26

4 Application

the tuner gain G_t and the tuner noise figure F_t taken as parameters. According to Fig.26 on the condition that the tuner gain is larger than 30dB, the deterioration of the noise figure of the total system does not exceed 1dB even when the power loss of the SAW filter is 24dB. Thus, when using a SAW filter in the postamplifier system it is desirable to connect a high gain tuner, and in order to prevent the deterioration of the SN ratio at high input level, it is desirable to use a tuner which has higher signal level at which AGC begins to operate. (i.e., Handling signal level of mixer transistor (or FET) of the tuner is high). Fig.27 shows calculation results of the noise figure of total system assuming postamplifier noise figure is 2dB, 3dB and 4dB. These results show that the noise figure of postamplifier has less effective upon the noise figure of total system than the gain and noise figure of the tuner, Fig.28 presents the calculation results of the noise figure of the total system assuming that VIF ICs noise figure is 6dB, 8dB and 10dB. The 3 curves are almost superimposed. As a result, the deterioration of the SN ratio due to the insertion loss of the SAW filter can be avoided by using the convenient tuner.

- Use of a high impedance SAW filter in the postamplifier system.

We have said that the low impedance SAW filter is better to use for postamplifier system because the terminating impedance of SAW filter is limited to low, high impedance SAW filters can also be usable by means of series coil tuning, as described below. The SAW filter impedance can be expressed by means of the parallel expression and the series expression, as shown in Fig.12, which can be converted mutually. For series coil tuning, it is easier to analyze with the equivalent circuit with the series expression. Tuned with series coil, the apparent impedance of the SAW filter becomes R_{si} (R_{so}). Table (2) shows the R_{si} (R_{so}) of the series expression is very small compared with R_{pi} (R_{po}) of the parallel expression. The impedances of high impedance type SAW filter SAFGN58M7VH0Z00B03, SAFGN45VA0Z00B03 become very low of the order of 50Ω. Thus, even the high impedance SAW filters can be used in the postamplifier system by means of the series coil tuning. Fig.29 shows an example of a circuit using a high impedance type SAW filter in the postamplifier system. Since the output side of the SAW filter is connected to the postamplifier, of which input impedance is of the order of 50 to 100Ω, which brings a heavy mismatching. The input side of the SAW filter is close to the matching thanks to the series tuning coil, as a whole total power loss becomes high to suppress the TTE.

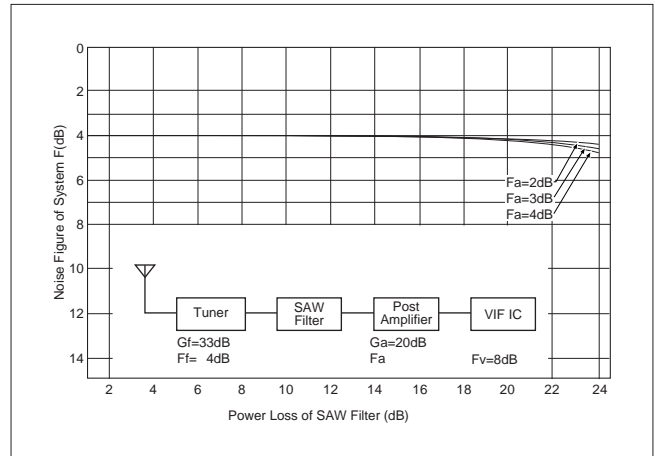

Fig.27

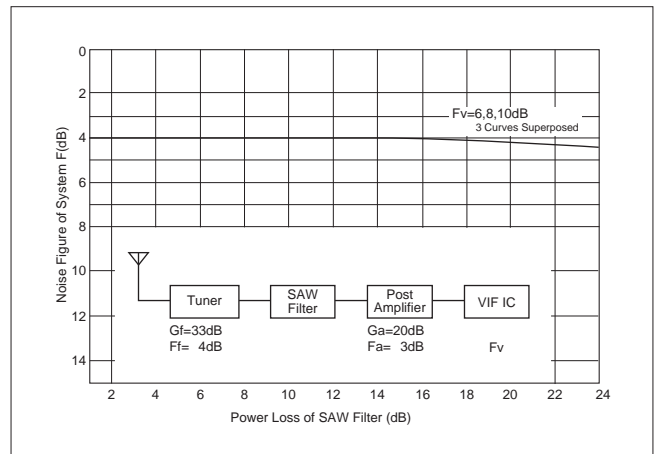

Fig.28

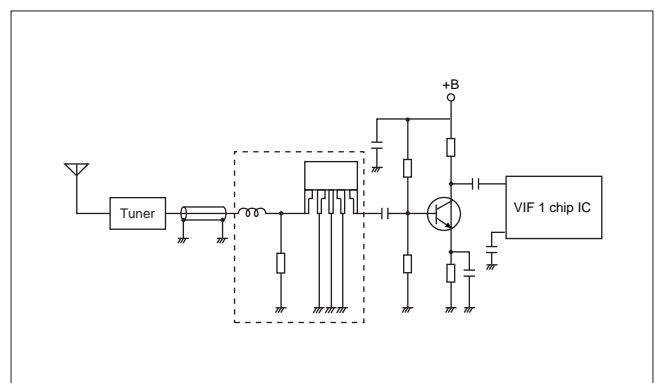

Fig.29 Use of a High Impedance Type SAW Filter in the Postamplifier System

Application 4

4-2-3. Method for the Compensation of the Insertion Loss without Amplifier

The gain of the 1 chip VIF IC can be increased, it is possible to leave out the insertion loss compensation amplifier, as shown in Fig.30. From another point of view, it is possible to say that the postamplifier described previously was absorbed in the VIF 1 chip IC. Now, the power loss and the voltage loss are related as follows, as described in 3-6-3,

$$\text{Power loss} = \text{Voltage loss} + \log (R_L/4R_s)$$

Assuming that the power loss has a certain value (const.) to suppress the TTE, the voltage loss can be made small by increasing the R_L/R_s ratio. The output impedance of the tuner, which is the signal source of the SAW filter, is assumed to have a fixed value of 75Ω . On the other hand, generally the input impedance of the 1 chip IC for VIF, at the load side, is relatively high, of the order of 1 to $3k\Omega$. Thus, it is desirable to use it without reducing the impedances have a fixed values, like this case, it is necessary to modify the circuit constants to adopt SAW filter for the given conditions. Fig.31 shows examples of circuits with high impedance type SAW filter and low impedance type SAW filter, respectively. In case of the high impedance type of Fig.31 (a), the output side is tuned by means of a parallel coil, and is practically matched with the $1k\Omega$ load impedance. In the low impedance case of Fig.31 (b), since the impedance of a SAW filter has a low value, of the order of several hundred Ohms even when tuned by a parallel coil, the impedance is increased by means of a transformation circuit like that described in 4-2-1. As both circuits can attain the insertion loss of approximately 12dB, as a result, the amplifier for compensation of insertion loss can be abridged, provided the VIF 1 chip IC's gain is increased a little.

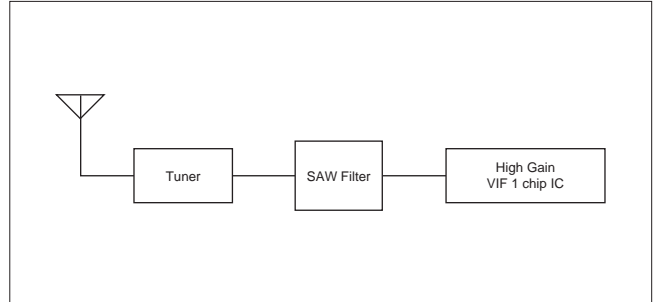

Fig.30 Configuration without Amplifier for Compensation of Insertion Loss

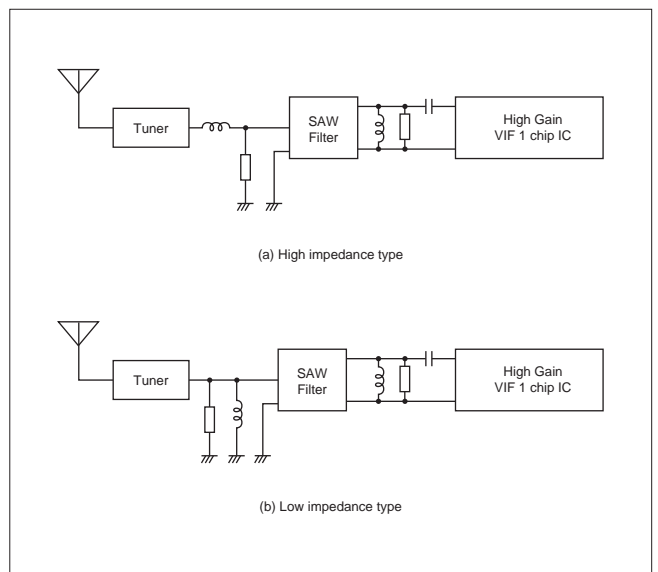

Fig.31

4

5 Appendix

5-1. Two Detection Methods and the Specification of the Surface Acoustic Wave Filter

There are two detection methods for the 1 chip IC of the VIF, which are shown in Fig.32 (a) and (b). Both methods adopt the LLD (Low Level Detector), of a synchronous detection method. In (a) the intercarrier type sound IF detection and video detection are performed by the same detector, but in (b) they are separated. In (b) the signal is divided in two, one is supplied to the sound IF detector and another is supplied to the video detector through the sound carrier trap. In (a) there is the problem of the 920kHz beat ($f_c - f_s$). we can not increase excessively the level of the sound carrier, so that sound carrier attenuation of the SAW filter should be required of the order of 18dB to 24dB from the peak. On the other hand, in the method (b), since a sound carrier trap is inserted before the video detector, there is no problem of 920kHz beat. In this case, in order to increase the output of the sound IF, sound carrier attenuation of the SAW filter should be required to have the order of 10dB to 18dB from the peak. As a result there are two required frequency characteristics of SAW filter (especially the attenuation at the sound carrier frequency) depending upon the type of IC used (detection method used).

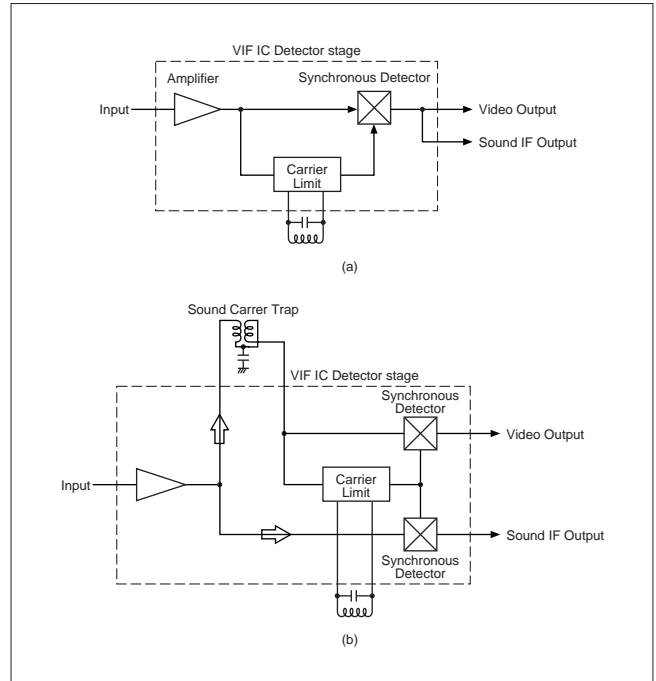

Fig.32 Two Detection Methods

5-2. TTE and Direct Breakthrough

Suppose the TTE and the direct breakthrough are not sufficiently suppressed, there will be a superposition of signals with time delay (or advance) upon the main signal, producing as a result ghost troubles upon the picture of the television set. For the TTE, since its delay is 2τ sec. with regard to the main signal, the ghost will appear at the right side, and for the direct breakthrough, the ghost will appear at the left side due to its τ sec. advance^(*). Whether TTE and direct breakthrough are suppressed sufficiently can be observed by the amplitude characteristics and the group delay time characteristics of the VIF stage. In other words, as TTE or direct breakthrough interferences with the main signal, to result in periodic ripples in the amplitude characteristics and group delay time characteristics, the suppression of the TTE and direct breakthrough can be inferred from magnitude of the ripples. The ripple period Δf is $1/2\tau$ Hz when caused by the TTE, and $1/\tau$ Hz when caused by the direct breakthrough. Thus, we can imagine roots of ripple by seeing the period of ripples. For example, in case of SAFGN58M7VH0Z00B03 τ is approximately 1.0 μ sec., and thus the period of the ripples due to TTE is

(*) See Fig.12

approximately 500kHz. High level of direct breakthrough makes not only the ripples in the group delay time and amplitude but also the trap depths reduction as shown in Fig.33, with deterioration in the attenuation level outside the pass band. As described previously TTE level can be suppressed to less than -40dB by increasing the power loss to a value larger than 18dB, by means of the mismatching. On the other hand, the level of the direct breakthrough is influenced by the printed circuit layout. The causes of the direct breakthrough can be classified in 3 items:

- Electrostatic causes like stray capacitance, etc.
- Electromagnetic inductions due to the currents passing through the printed pattern
- Due to the residual resistance of the common ground.

With regard to the electrostatic causes, the printed Input/Output patterns should be made sufficiently small and short, VIF stage including VIF IC, SAW filter etc. should be shielded from other stage, In many cases, the design of the earth pattern has an important influence upon the direct breakthrough level. In conventional LC filters, every free space on the printed circuit board is filled as much as possible with earth pattern, which is mutually connected wherever possible. However, this configuration is not suited for the case of the SAW filter. This configuration creates many earth path loops, and the currents passing through these loops often make the coupling between the input and output. Due to same reasons, the earth position of the bypass capacitor of the amplifier for insertion loss compensation must be selected with special care. When designing the pattern of the printed circuit, it is recommendable to prepare initially a provisional pattern, and then cut some of the many earth path by means of the cut and try method, until minimizing the bottom level outside the pass band. Fig.34 shows the frequency characteristic of the video detector output when the direct breakthrough is sufficiently suppressed, and when the suppression is not sufficient, respectively. In Fig.34 (a) , since the direct breakthrough is sufficiently suppressed, only the small TTE ripple with $1/2\tau$ period exists. In Fig.34 (b) there is a superposition of the double period ripple caused by the direct breakthrough upon the TTE ripple, and as result large ripple and small ripple appear alternatively.

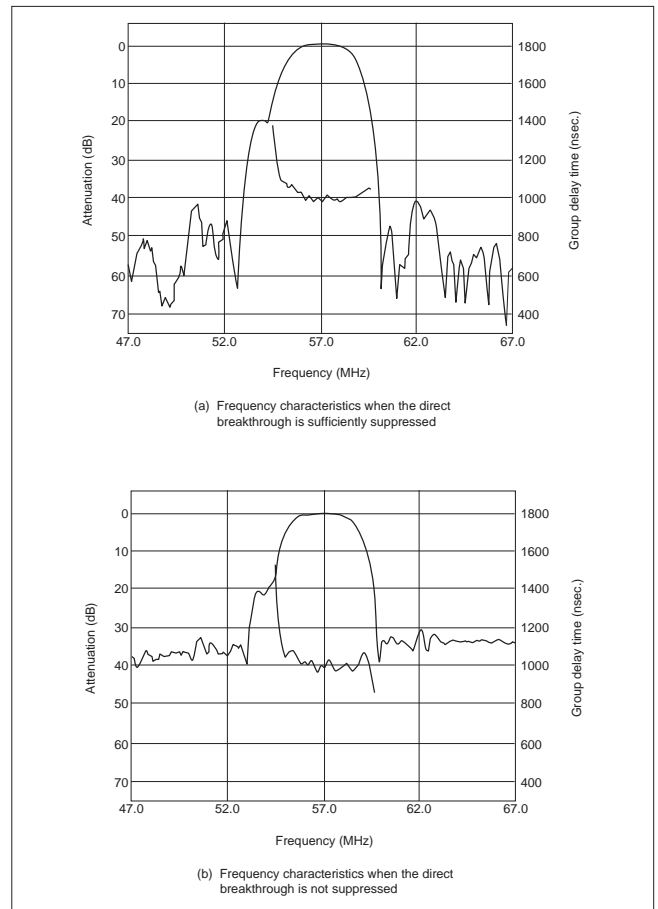

Fig.33

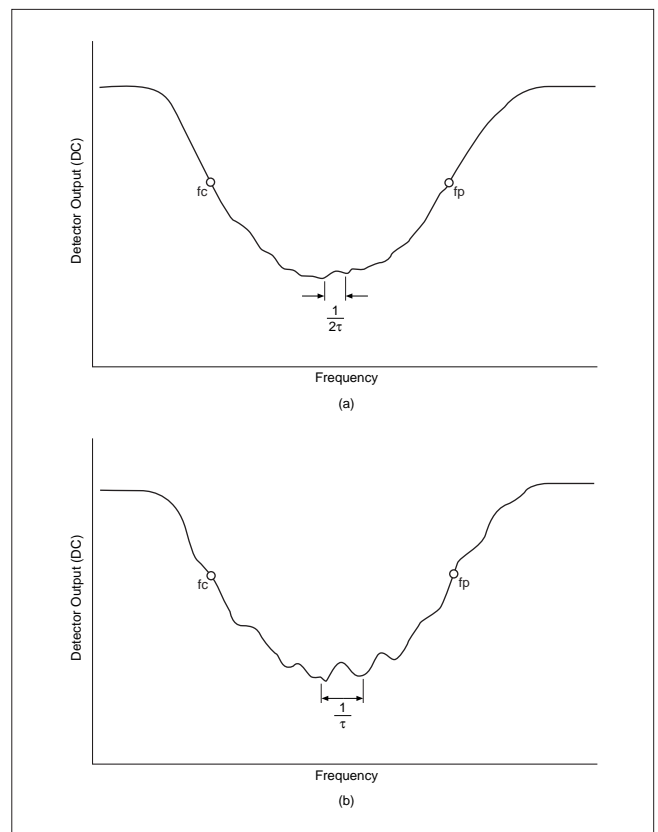

Fig.34

5 Appendix

5-3. Impedance of the Surface Acoustic Wave Filter

So far, the discussions related to the impedance of the SAW filter refer to the equivalent circuit of Fig.12 with the value of the resistor and the capacitor considered as constant value. However, the values of both capacitor and resistor present a frequency dependence. For example, Fig.35 and 36 present the frequency characteristics of R_{pi} , C_{pi} and R_{po} and C_{po} of SAFGN58M7VH0Z00B03. The input side (R_{pi} , C_{pi}) and the output side (R_{po} , C_{po}) present different frequency characteristics due to the difference of the IDT. While output the IDT is of normal electrode of the constant overlap and constant pitch, the input IDT is of the apodized (weighted) one. The measurement result of the input impedance of SAFGN58M7VH0Z00B03 including the series tuning coil plotted in a Smith chart is shown in the dotted line of Fig.37 (Since SAFGN58M7VH0Z00B03 is a high impedance type filter, it is tuned in series in order to lower its impedance to around 75Ω). For the purpose of reducing the return loss of mismatching and the remarkable change in the frequency characteristic by the direct connection of the tuner output and the SAW filter, it is necessary to minimize the variation of the impedance of SAW filter including matching network from 75Ω . One action is adding a resistor as shown in Fig.38 which is effective to adjust input impedance of SAW filter constant. Solid line of Fig.37 shows the impedance characteristic when the resistor is added and we can see variation from 75Ω become small. However, In this case, the power consumed by the attached resistor increases the loss. We have said at 4-1-2 that it is a problem that tuner output impedance varies much with frequencies in case of the direct connection of tuner and SAW filter. The connection can be easily made if impedance of SAW filter is adjusted constant by means of this method.

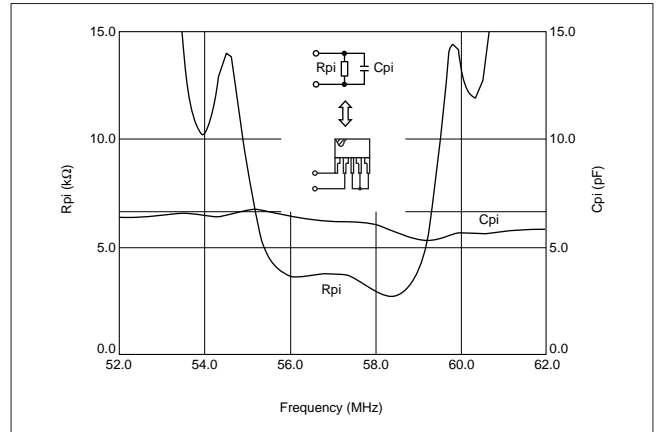

Fig.35

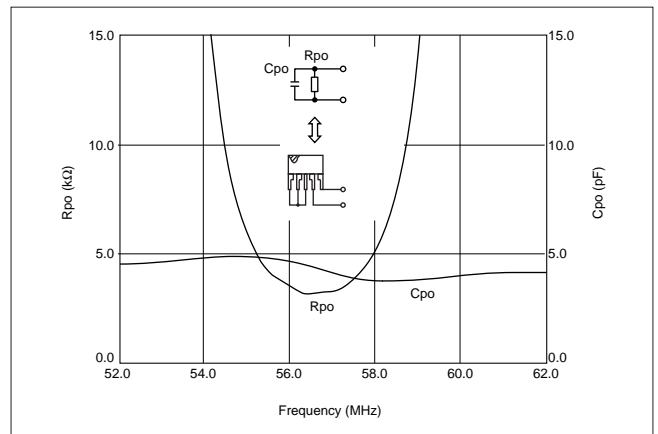

Fig.36

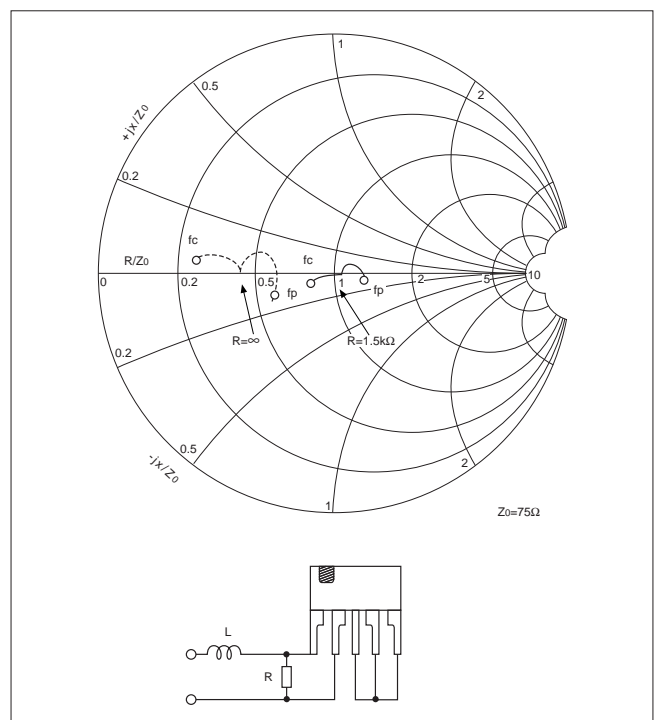

Fig.37

Appendix 5

● Reference

When the impedance is adjusted by adding a resistance, as shown in Fig.38 (a), (b), (c), there is an additional advantage, which is the damping of the frequency dependence of the radiation resistance R_P (R_s), but at the same time it has a disadvantage, which is the increase of loss. The transformation of impedance without the increase of power loss can be performed as shown in Fig.39 (a) and (b), but the damping of the radiation resistance variation can not be expected.

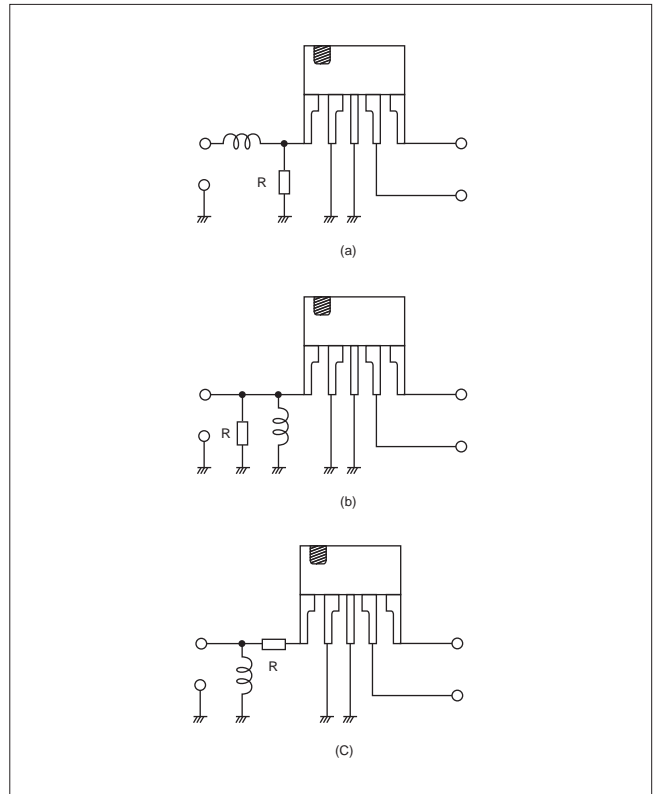

Fig.38 Impedance Adjustment by Means of the Resistor R

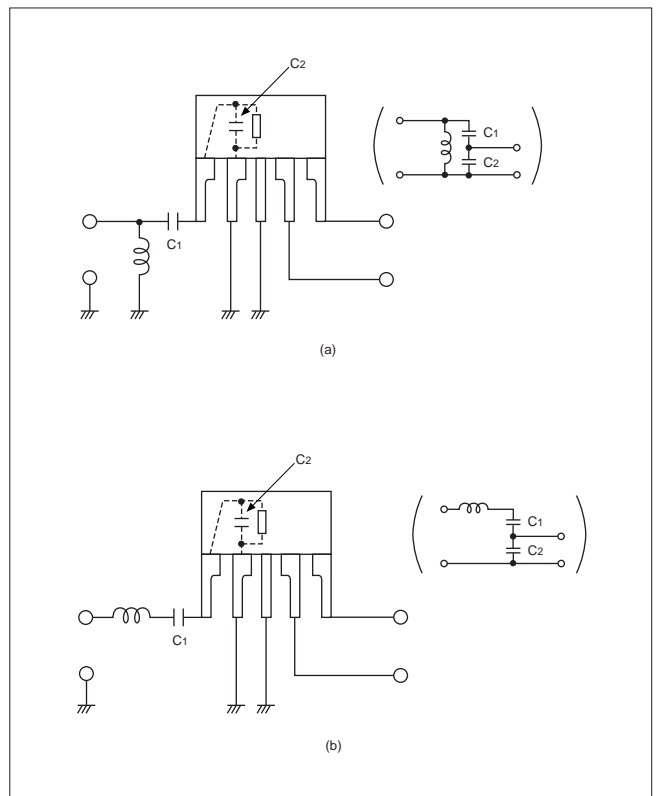

Fig.39

5 Appendix

5-4. Reliability Test

Surface acoustic wave filter should be used carefully not to exceed the maximum rating shown in Table 3 below. Murata performs periodic reliability tests for the SAW filter. The conditions of them are shown in Table 4. The data of SAFGN58M7VH0Z00B03 are shown in Fig.40, which shows that the variation is small enough compared to the limit. (Table 5).

Test Items	Test Conditions
Vibration	600 - 3300 r.p.m. Amplitude (P.P.) 1.5mm X,Y,Z directions, 2h each
Drop	100cm, 3 times
Lead Pull	1 kg, 15 seconds
Lead Bend	0.3kg, 1 return
Heat Resistivity for Melt Solder	260°C, 10 seconds
Soldering	230°C 5sec. covered with solder more than 90% of the lead
Humidity Test	60°C, 500 hours, 95% RH
Thermal Stress Test	-55°C 30 min. □ +85°C 30 min. 5 cycles
High Temperature Test	85°C, 500 hours
Low Temperature Test	-40°C, 500hours

Table 4 Reliability Test Conditions

Items	Maximum Rating
DC Voltage	10V
Pulse Voltage	150V/200pF
Input Signal Voltage	5Vp-p
Operating Temperature	-20 - +60°C.
Storage Temperature	-40 - +85°C.

Table 3 Maximum Ratings

Insertion Loss Variation	±1.5dB max.
fp Variation	±1dB max.
fc Variation	±1dB max.
fs Variation	±1.5dB max.

Table 5 Limit

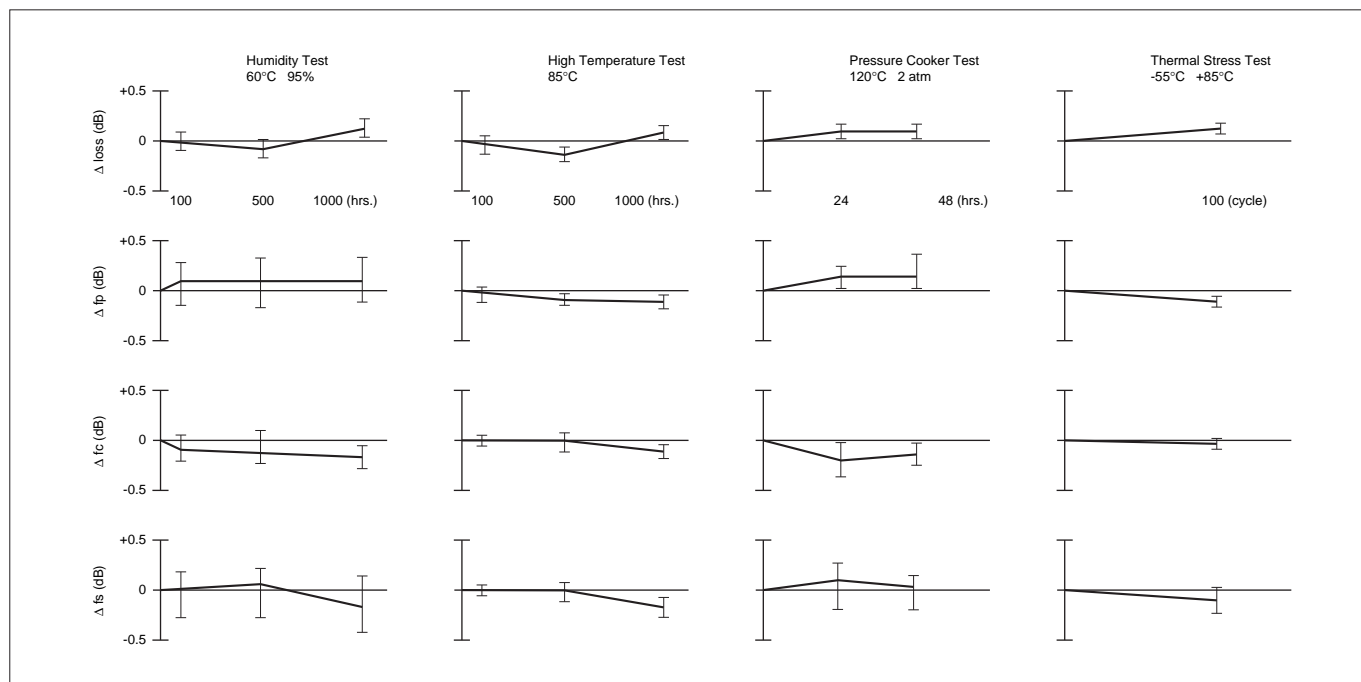

Fig.40 Reliability Test Result of SAFGN58M7VH0Z00B03

5-5. Notice (handling)

- Electric characteristics may vary if you use SAW filter without cutting off the DC voltage.
- If static high voltage is applied between input terminals or output terminals, the SAW filter may be destroyed.
- Electric characteristics may vary if the lead is contact with a heated soldering iron for a long time.
- Inserting SAW filter in the direction opposite to the input mark makes frequency characteristics degraded.

⚠Note:

1. Export Control

⟨For customers outside Japan⟩

No muRata products should be used or sold, through any channels, for use in the design, development, production, utilization, maintenance or operation of, or otherwise contribution to (1) any weapons (Weapons of Mass Destruction (nuclear, chemical or biological weapons or missiles) or conventional weapons) or (2) goods or systems specially designed or intended for military end-use or utilization by military end-users.

⟨For customers in Japan⟩

For products which are controlled items subject to the "Foreign Exchange and Foreign Trade Law" of Japan, the export license specified by the law is required for export.

2. Please contact our sales representatives or product engineers before using the products in this catalog for the applications listed below, which require especially high reliability for the prevention of defects which might directly damage a third party's life, body or property, or when one of our products is intended for use in applications other than those specified in this catalog.

- | | |
|-----------------------------|--|
| ① Aircraft equipment | ② Aerospace equipment |
| ③ Undersea equipment | ④ Power plant equipment |
| ⑤ Medical equipment | ⑥ Transportation equipment (vehicles, trains, ships, etc.) |
| ⑦ Traffic signal equipment | ⑧ Disaster prevention / crime prevention equipment |
| ⑨ Data-processing equipment | ⑩ Application of similar complexity and/or reliability requirements to the applications listed above |

3. Product specifications in this catalog are as of August 2001. They are subject to change or our products in it may be discontinued without advance notice.

Please check with our sales representatives or product engineers before ordering. If there are any questions, please contact our sales representatives or product engineers.

4. Please read rating and ⚠CAUTION (for storage, operating, rating, soldering, mounting and handling) in this catalog to prevent smoking and/or burning, etc.

5. This catalog has only typical specifications because there is no space for detailed specifications. Therefore, please approve our product specifications or transact the approval sheet for product specifications before ordering.

6. Please note that unless otherwise specified, we shall assume no responsibility whatsoever for any conflict or dispute that may occur in connection with the effect of our and/or a third party's intellectual property rights and other related rights in consideration of your use of our products and/or information described or contained in our catalogs. In this connection, no representation shall be made to the effect that any third parties are authorized to use the rights mentioned above under licenses without our consent.

7. No ozone depleting substances (ODS) under the Montreal Protocol are used in our manufacturing process.

***muRata* Murata Manufacturing Co., Ltd.**

<http://www.murata.com/>

Head Office
1-10-1, Higashi Kotari, Nagaokakyo-shi, Kyoto 617-8555, Japan
Phone: 81-75-951-9111

International Division
3-29-12, Shibuya, Shibuya-ku, Tokyo 150-0002, Japan
Phone: 81-3-5469-6123 Fax: 81-3-5469-6155 E-mail: intl@murata.co.jp

Cat. No. P06E-3