

# Thin Film Circuit Substrate (RUSUB™) For Photo Diode Module

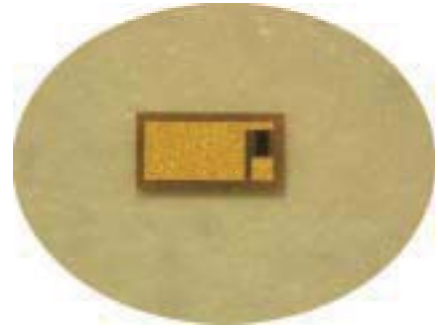

RUCYT101K00009GNTC  
(Size: 1.0 × 0.5mm)

## Example

【Example of circuit block for Photo Diode Module】

【Example of surface-mounted component for Photo Diode Module】

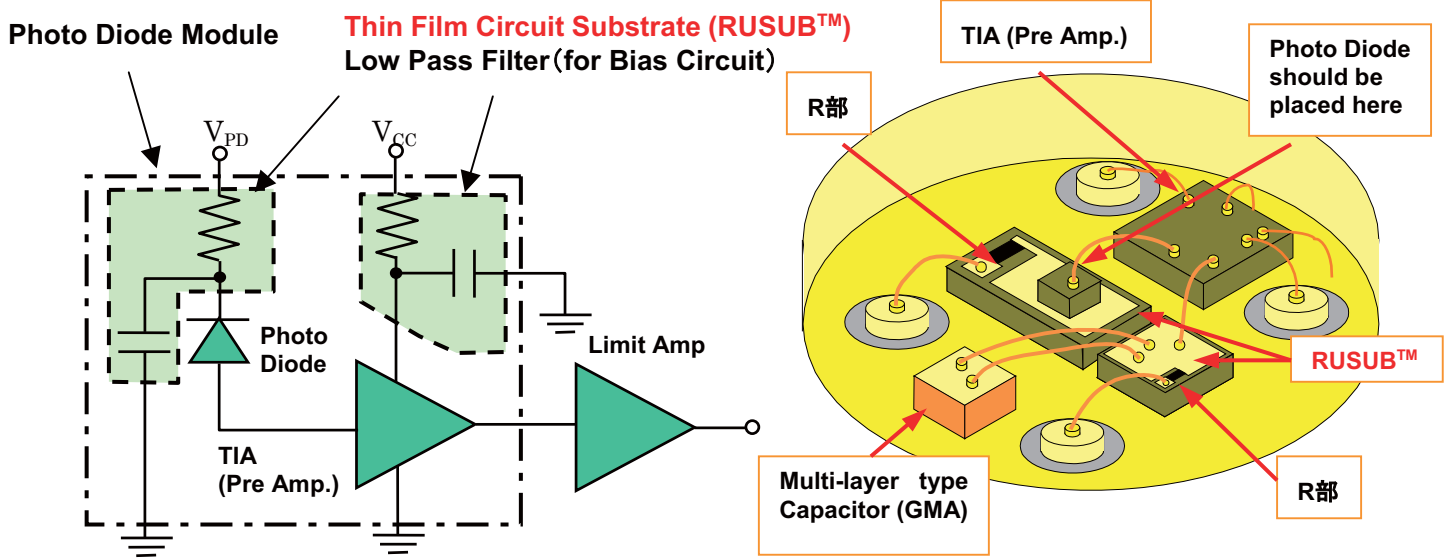

Photo Diode on RUSUB™

## Features

- RUSUB™ technology provides single-layer capacitor and thin film resistor formed in one chip. It reduces not only numbers of parts to build a device, but also the assembly costs. It will also contribute to make a device smaller.
- The single-layer structure makes its self-resonant frequency higher. It allows the devices to operate stable even at a high frequency range.
- Short distance between the capacitor and thin film resistor makes the residue inductance smaller and it contributes to attenuate unnecessary noise. So the device can work at its best characteristics.
- Since it has gold electrode, it is feasible to be installed inside a module, and it allows wire-bonding with gold wire.
- AuSn pre-coating finish is also available.
- It is very suitable for APD(Avalanche Photo Diode), because the capacitor has withstanding voltage of 100V.

## Main Application

- Low pass filter for power supply of PD(Photo Diode).
- Low pass filter for power supply of TIA (Transimpedance Amp. = Pre Amp.) .

## The effect of C+R substrate

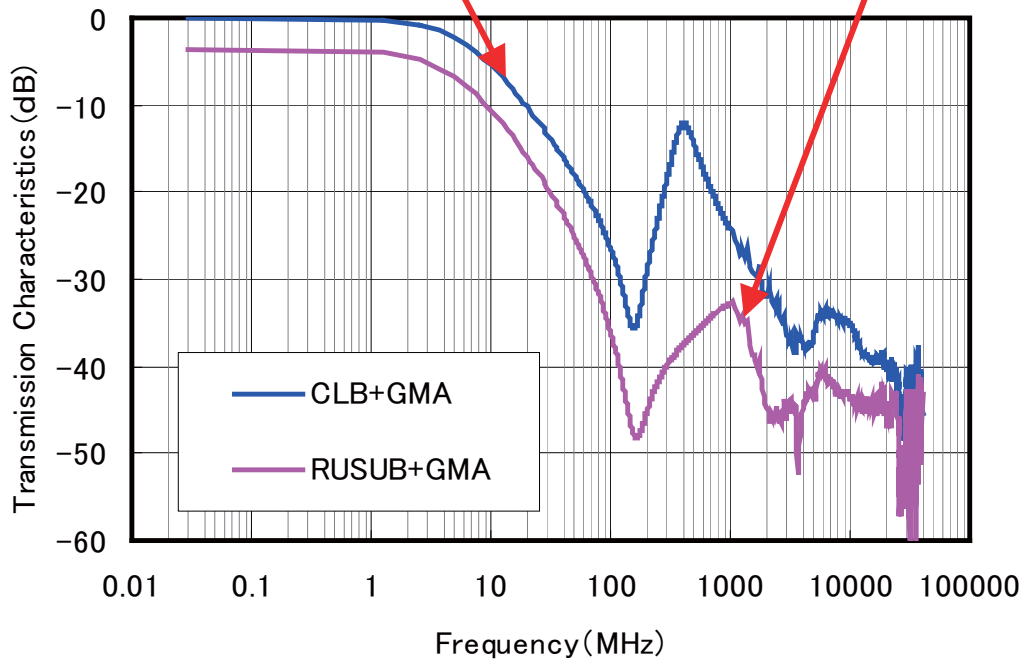
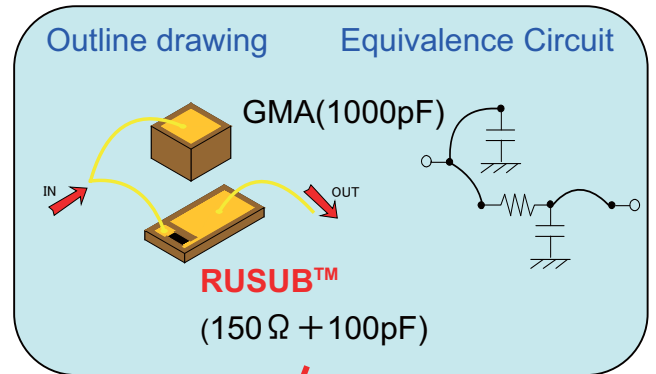
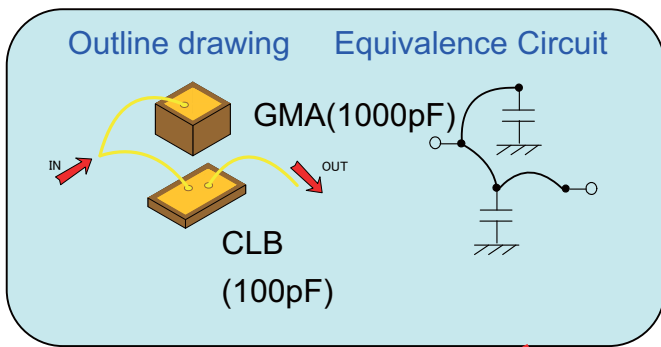

**Parallel circuit of GMA and CLB cuts off the noise but can't provide flat attenuation.**

**However GMA and RUSUB™ provide flat attenuation through out the wide band.**

## Specification

Parameter	Value
Temperature characteristics of Capacitance (TC) @-25° C to +85° C	+/- 10%
Capacitor Rated Voltage	100V
Temperature Coefficient of Resistance (TCR)	-70 ± 50ppm/° C
Resistor Rated Power	100mW/mm <sup>2</sup>
Dielectric constant (εr)	3000(typ.)
Structure of metalized film	Top Side : Ta/N/Ti/Pd/Au(Mn 4um) Bottom Side : Ti/Pd/Au(Mn 4um)

## Product Example

- Six types of standard samples of RUSUB™ C+R (Capacitor + Resistor) for evaluation are available.
- The individual substrate size, capacity, resistance value, and electrode pattern shape is available upon request.

Part Number	Size	Thickness	Capacitance	Resistance
RUCYT101K00009GNTC	1.0mm x 0.5mm	0.11 +/- 0.025mm	100pF +/- 10%	50Ω +/- 20%
RUCYT101K00011GNTC	1.0mm x 0.5mm	0.11 +/- 0.025mm	100pF +/- 10%	100Ω +/- 20%
RUCYT101K00012GNTC	1.0mm x 0.5mm	0.11 +/- 0.025mm	100pF +/- 10%	200Ω +/- 20%
RUCYT201K00010GNTC	1.0mm x 1.0mm	0.12 +/- 0.025mm	200pF +/- 10%	50Ω +/- 20%
RUCYT201K00013GNTC	1.0mm x 1.0mm	0.12 +/- 0.025mm	200pF +/- 10%	100Ω +/- 20%
RUCYT201K00014GNTC	1.0mm x 1.0mm	0.12 +/- 0.025mm	200pF +/- 10%	200Ω +/- 20%

## Shape

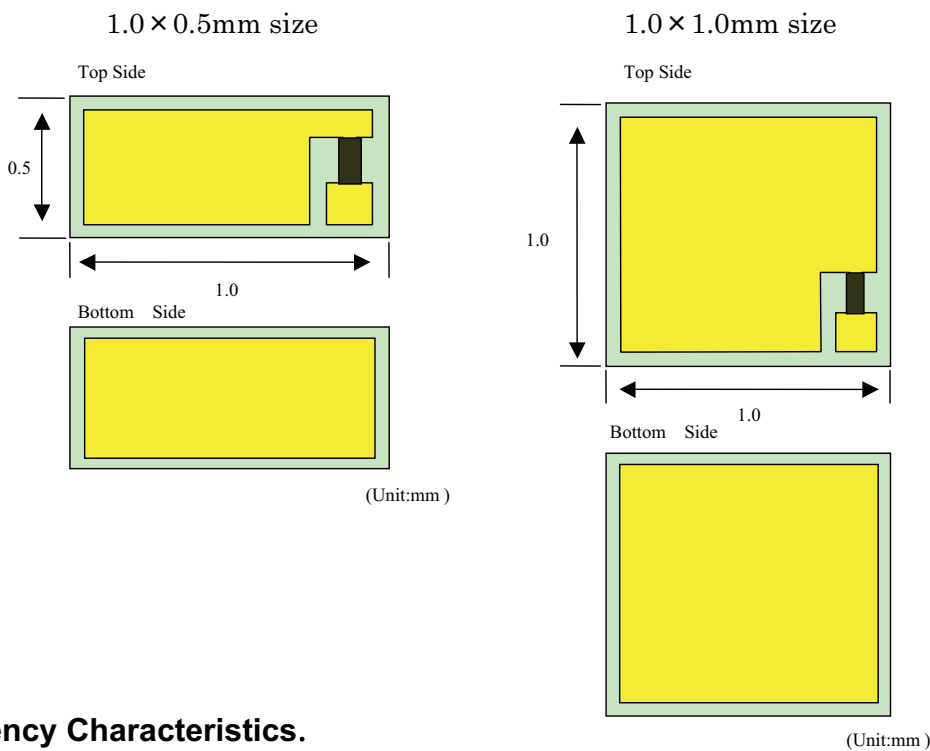

## Frequency Characteristics.

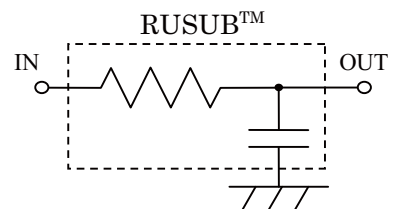
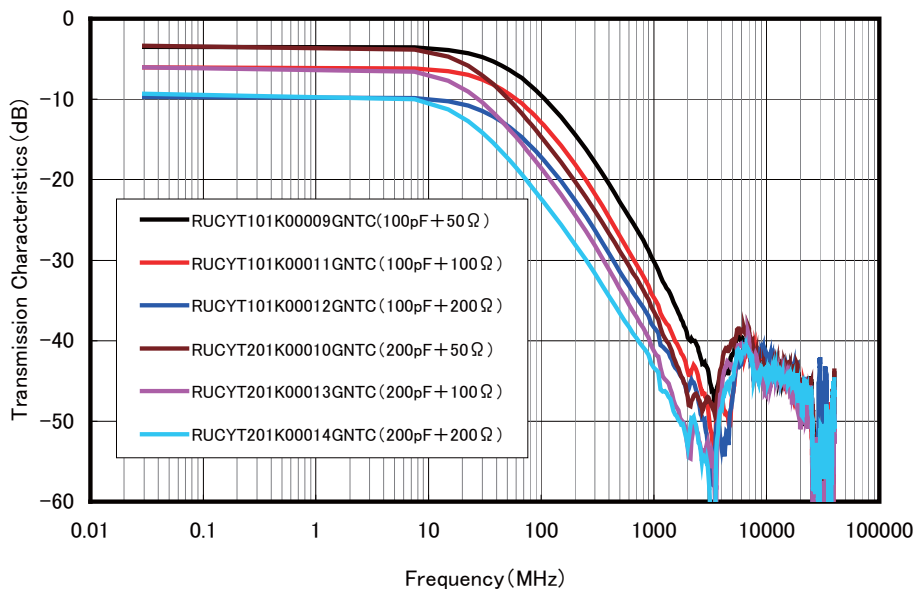

Fig. Equivalent circuit  
(Measured at 50ohm)