

# Piezoelectric Sound Components

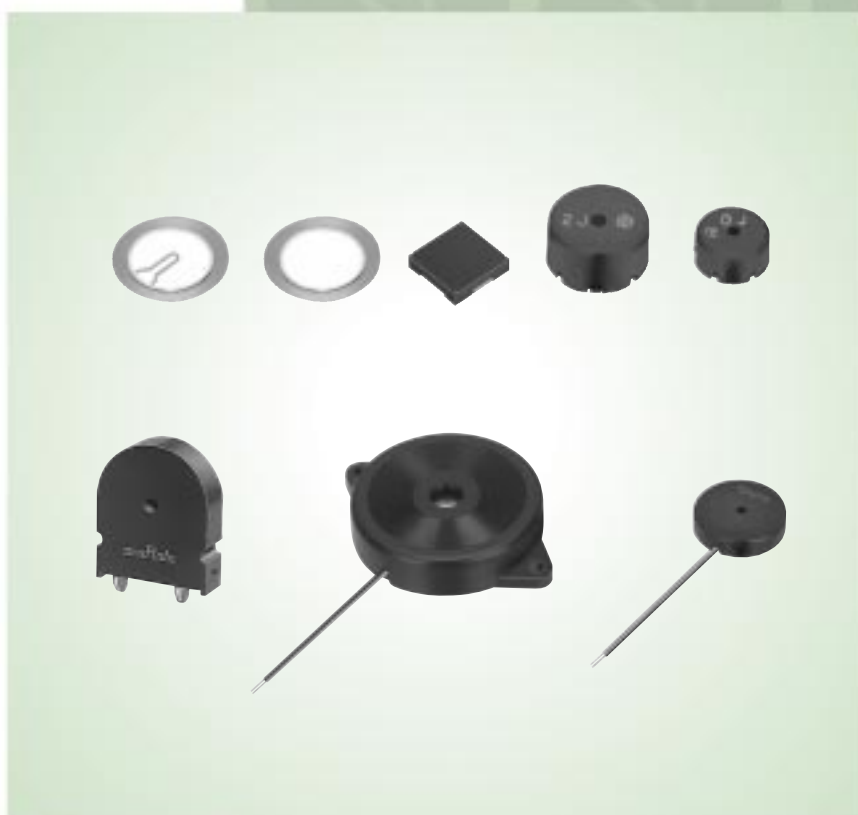

## *Application Manual*

***muRata*** *Innovator  
in Electronics*

**Murata  
Manufacturing Co., Ltd.**

## **Introduction**

---

Murata is active in R&D of new electronic components, seeking infinite possibilities with ceramic materials.

Particularly, as a pioneer in the development of piezoelectric ceramics, Murata has met the needs of the technical revolution in electronics with original products.

Our ceramic resonators (CERALOCK®), ceramic filters (CERAFIL®), piezo sound components and various ultrasonic transducers have contributed to the development of electronics.

The "Piezoelectric sound components" introduced herein operate on an innovative principle utilizing natural oscillation of piezoelectric ceramics. Today, piezoelectric sound components are used in many ways such as home appliances, OA equipment, audio equipment telephones, etc. And they are applied widely, for example, in alarms, speakers, telephone ringers, receivers, transmitters, beep sounds, etc.

This manual is made for customers to use piezoelectric sound components efficiently and with no trouble. It is recommended that the manual be read while referring to the catalog.

<b>1</b>	<b>Type of Piezoelectric Sound Components and Oscillating System</b> .....	2
	1. Type of Piezoelectric Sound Components .....	2
	2. Oscillating System .....	2
<b>2</b>	<b>Procedures</b> .....	3
	1. Soldering Procedures .....	3
	2. Design Procedures .....	3
	3. Drive Procedures .....	4
	External drive method .....	4
	Self drive method .....	5
	4. To Raise Up Sound Pressure Level (S.P.L.) .....	6
<b>3</b>	<b>Characteristics and Measuring Method</b> .....	8
	1. Characteristics .....	8
	2. Measuring Procedure .....	8
	Measurement of Resonant Frequency and Resonant Impedance ...	8
	Measurement of Sound Pressure Level (S.P.L.) .....	9
<b>4</b>	<b>Environmental Characteristics</b> .....	10
	1. Voltage and Temperature Characteristics .....	10
	2. Environmental Tests .....	10

# CONTENTS

## 1 Type of Piezoelectric Sound Components and Oscillating System

## 2 Procedures

## 3 Characteristics and Measuring Method

## 4 Environmental Characteristics

# 1 Type of Piezoelectric Sound Components and Oscillating System

## 1. Type of Piezoelectric Sound Components

Type	Driving Procedures			Standard Part Number
	External Drive	Self Drive	Built-in Circuit	
Piezoelectric Diaphragm	○	○		7BB-15-6, 7BB-35-3C
Piezoelectric Sounder	○	○		PKLCS1212E4001-R1, PKM13EPYH4002-B0
Piezoelectric Buzzer		○	○	PKB24SPCH3601-B0

## 2. Oscillating System

Basically, the sound source of a piezoelectric sound component is a piezoelectric diaphragm. A piezoelectric diaphragm consists of a piezoelectric ceramic plate which has electrodes on both sides and a metal plate (brass or stainless steel, etc.).

A piezoelectric ceramic plate is attached to a metal plate with adhesives. Fig. 2 shows the oscillating system of a piezoelectric diaphragm.

Applying D.C. voltage between electrodes of a piezoelectric diaphragm causes mechanical distortion due to the piezoelectric effect. For a misshaped piezoelectric element, the distortion of the piezoelectric element expands in a radial direction. And the piezoelectric diaphragm bends toward the direction shown in Fig. 2 (a). The metal plate bonded to the piezoelectric element does not expand. Conversely, when the piezoelectric element shrinks, the piezoelectric diaphragm bends in the direction shown in Fig. 2 (b). Thus, when AC voltage is applied across electrodes, the bending shown in Fig. 2 (a) and Fig. 2 (b) is repeated as shown in Fig. 2 (c), producing sound waves in the air.

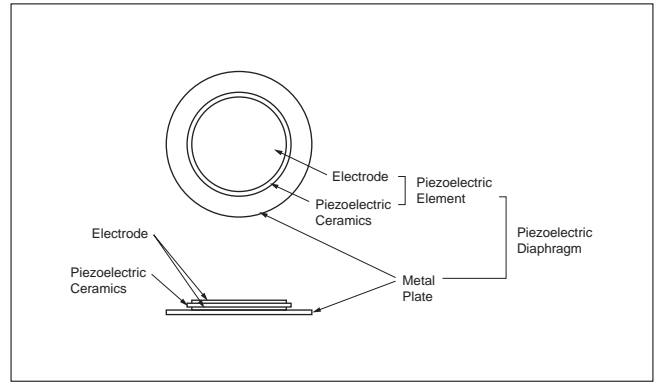

Fig. 1 Structure of Piezoelectric Diaphragm

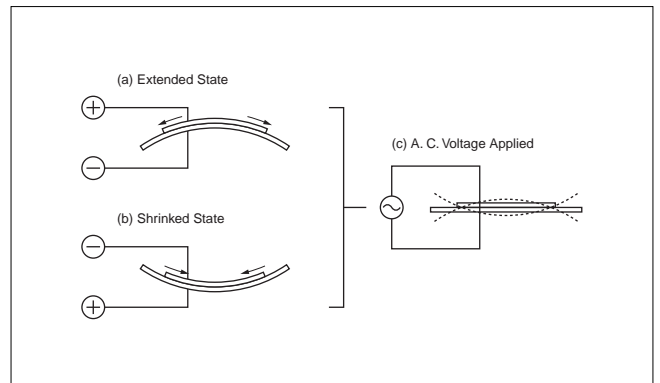

Fig. 2 Oscillation System

# 2 Procedures

## 1. Soldering Procedures

A lead wire is needed to apply voltage to the piezoelectric diaphragm. When using a soldering iron, the optimum temperature for soldering a lead wire to a metal plate is 320 to 350°C for 3 seconds and the same temperature for the ceramic electrode for 0.5 second or less. The lead wire should be as fine as possible, as it works as a load restricting oscillation of the piezoelectric diaphragm (Example: AWG32).

## 2. Design Procedures

In general, man's audible frequency range is about 20 Hz to 20kHz. Frequency ranges of 2kHz to 4kHz are most easily heard. For this reason, most piezoelectric sound components are used in this frequency range, and the resonant frequency ( $f_0$ ) is generally selected in the same range too. As shown in Fig. 3, the resonant frequency depends on methods used to support the piezoelectric diaphragm. If piezoelectric diaphragms are of the same shape, their values will become smaller in the order of (a), (b) and (c). In general, the piezoelectric diaphragm is installed in a cavity to produce high sound pressure (Fig. 4). The resonant frequency ( $f_{cav}$ ) of the cavity in Fig. 4 is obtained from Formula (1) (Helmholtz's Formula). Since the piezoelectric diaphragm and cavity have proper resonant frequencies, ( $f_0$ ) and ( $f_{cav}$ ) respectively, sound pressure in specific frequencies can be increased and a specific bandwidth can be provided by controlling both positions.

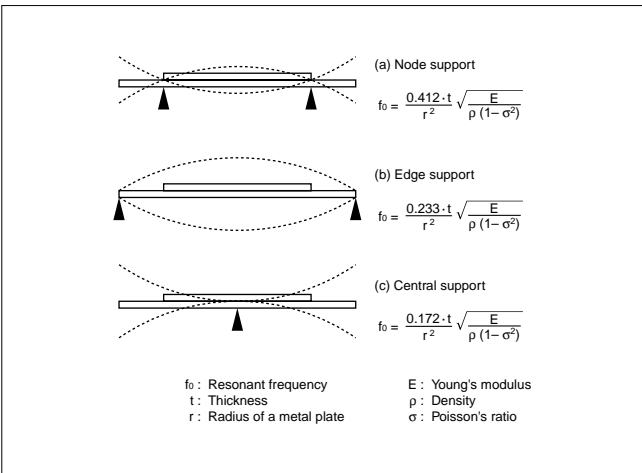

Fig. 3 Supporting Method

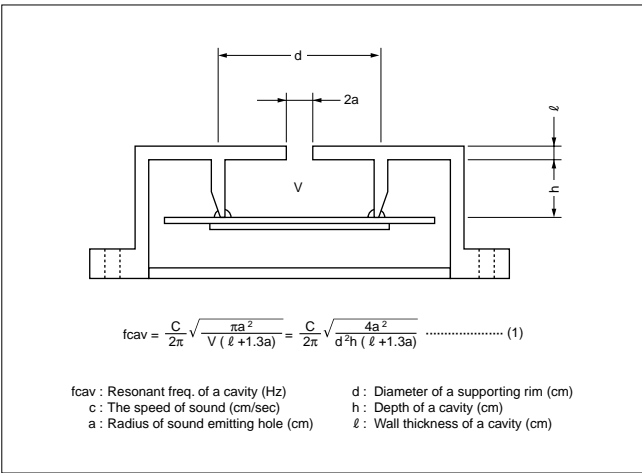

Fig. 4 Sectional View of a Cavity

## 2 Procedures

### 3. Drive Procedures

Drive procedures for piezoelectric sound components include (a) external drive method and (b) self drive method as shown in Fig. 5.

#### External Drive Method

This method produces sound by driving the piezoelectric diaphragm with electric signals supplied from an external oscillating circuit such as a multivibrator. Using this method, the piezoelectric buzzer can work as a speaker. In this method, a mechanical oscillation  $Q_m$  of the piezoelectric diaphragm is damped properly to provide a wider frequency band of the sound pressure. This is applied to a switching sounds of home electric appliances, key-in sounds of OA equipment, alarm sounds of digital watches and the multiple sounds like those used in electronic games. This method is also applied to the ringers, transmitters, receivers of telephone sets, card radios and speakers of crystal TV's. Fig. 6 shows examples of the circuit to which the external drive method is applied:

(i) represents a circuit driven by output signals of the unstable multivibrator; (ii) represents a circuit using 2 NAND gates, which is oscillated or stopped by ON / OFF operations of the input signal; (iii) represents a circuit driven by output signals of CMOS LSI; (iv) and (v) represent examples of the piezoelectric diaphragm connected to telephone tone ringer IC.

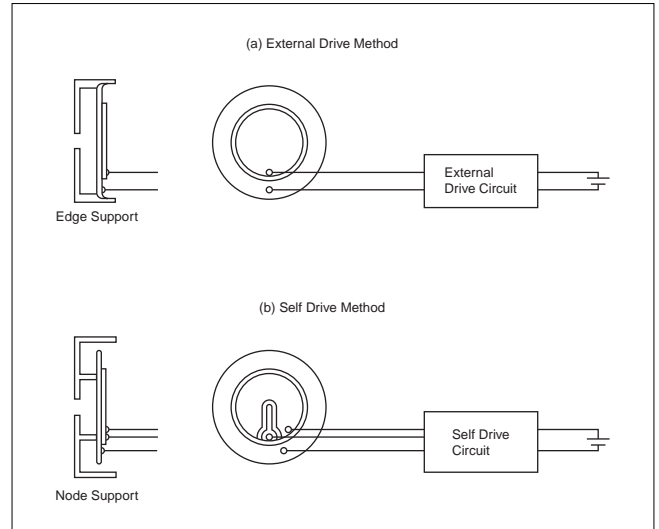

Fig. 5 Drive Procedures

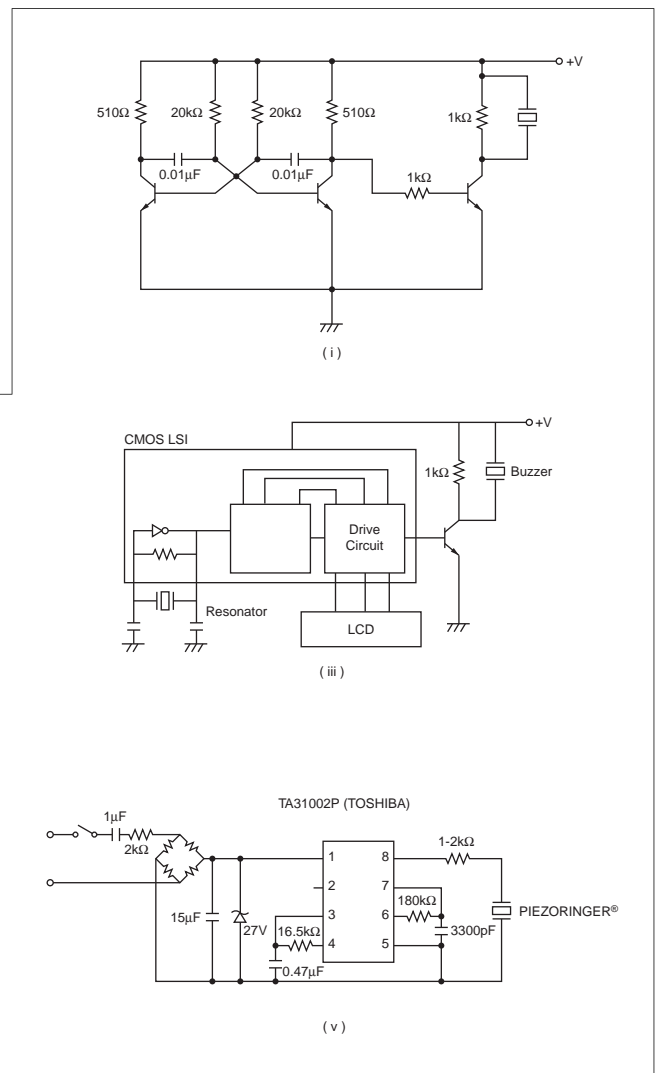

Fig. 6 Examples of the external drive circuits

## Procedures 2

### Notice (Handling) In Using External Drive Method

- 1) Electric charges accumulated in the piezoelectric diaphragm due to thermal and mechanical shock may cause high voltage which may destroy LSI. Use the method using a Zener diode as shown in Fig. 7 to prevent this.
- 2) Applying D.C. voltage to the piezoelectric diaphragm in the environment of high humidity causes Ag migration. Therefore, design a circuit which does not require D.C. voltage be applied for a long time.
- 3) Consider the following points in connecting a piezo ringer and tone ringer IC.
  - i) For external capacitors and resistors, especially when the ringing frequency is changed by adjusting variable resistor, tone may be distorted.
  - ii) Ringer ICs; ringer ICs are produced by many manufacturers, and have different characteristics. When using a ringer IC, consult us or its manufacturer for operating procedures.
  - iii) If tone is distorted as described in Fig. 8 (a), place a resistor in series to vary resistance as described in (b) and select a resistance with which the distortion can be eliminated. The recommended resistance is in a range between 1kohms to 2kohms. Alternatively, it is recommended to place a diode in parallel with the piezo ringer.

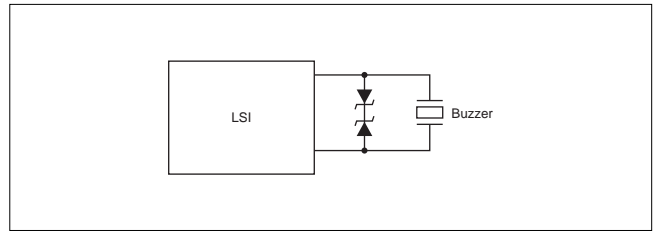

Fig. 7 Protect Circuit

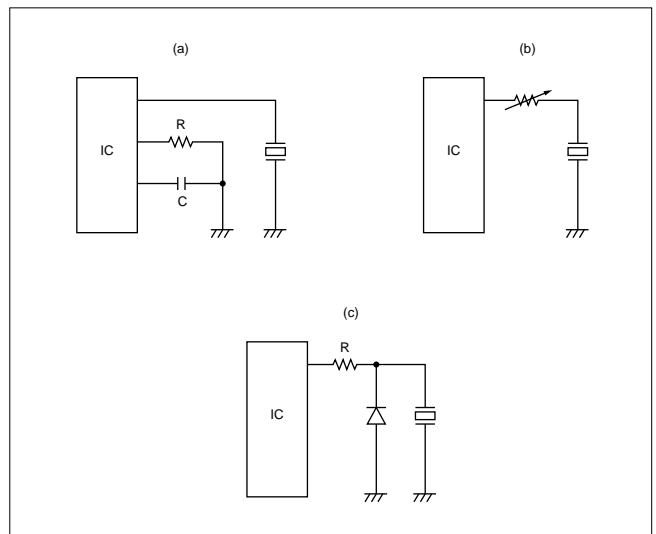

Fig. 8 Circuits for Piezo Ringers

### Self Drive Method

Fig. 9 shows a typical application of the self drive method. The piezoelectric diaphragm provided with feedback electrode shown in Fig. 9 (i) is involved in the closed loop of a Hartley types oscillation circuit. When the frequency is closed to the resonant frequency, the circuit satisfies oscillating conditions, and the piezoelectric diaphragm is driven with the oscillating frequency. Fig. 9 (ii) shows a simple oscillating circuit consisting of one transistor and three resistors. In general, the node support shown in Fig. 3 (a) is popular in the self drive method. Proper resonance of the piezoelectric diaphragm by the node support provides stable oscillation with high mechanical Qm of vibration but also a single high pressure tone.

Basic oscillating conditions of this circuit are shown below.

- a. Phase difference between  $v_o$  and  $v_f$  shown in Fig. 9 must be 180 degrees.
- b. The following conditions must be satisfied:

$$v_f / v_o \geq \frac{R_2 + h_{ie}}{h_{fe} \cdot R_3}$$

where;

$h_{ie}$ : Input impedance of transistor

$h_{fe}$ : Current amplification

- c. Set  $R_1$  so that the D.C. bias point of transistor, VCE is half of supply voltage.
- d. Adjust  $R_2$  so that spurious oscillation is not applied to oscillating waves.

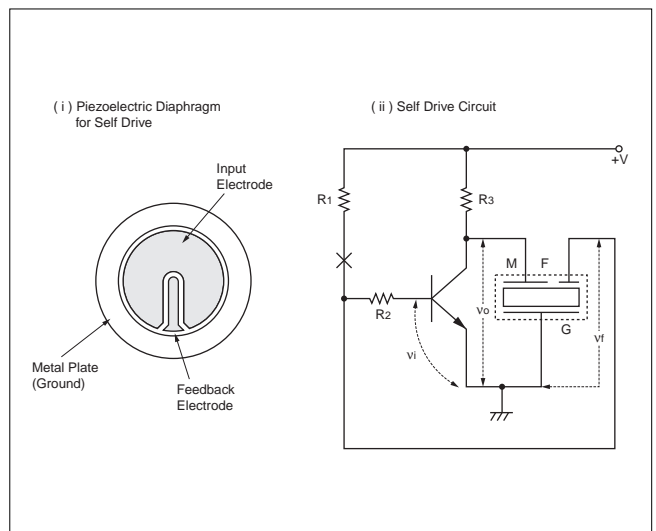
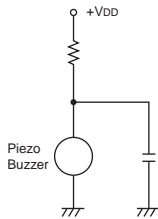

Fig. 9 Self Drive Circuit

## 2 Procedures

### Notice (Handling) In Using Self Drive Method

- 1) When the piezoelectric buzzer is set to produce intermittent sounds, sound may be heard continuously even when the self drive circuit is turned ON / OFF at the "X" point shown in Fig. 9. This is because of the failure of turning off the feedback voltage.
- 2) Build a circuit of the piezoelectric sounder exactly as per the recommended circuit shown in the catalog.  $h_{fe}$  of the transistor and circuit constants are designed to ensure stable oscillation of the piezoelectric sounder.
- 3) Design switching which ensures direct power switching.
- 4) The self drive circuit is already contained in the piezoelectric buzzer. So there is no need to prepare another circuit to drive the piezoelectric buzzer.
- 5) Rated voltage (3.0 to 20Vdc) must be maintained. Products which can operate with voltage higher than 20Vdc are also available.
- 6) Do not place resistors in series with the power source, as this may cause abnormal oscillation. If a resistor is essential to adjust sound pressure, place a capacitor (about 1 $\mu$ F) in parallel with the piezo buzzer.



- 7) Do not close the sound emitting hole on the front side of casing.
- 8) Carefully install the piezo buzzer so that no obstacle is placed within 15mm from the sound release hole on the front side of the casing.

## 4. To Raise Up Sound Pressure Level (S.P.L.)

It is probable that the S.P.L. of Piezoelectric sound components is larger as the input voltage is larger because Piezoelectric sound components are driven by voltage. The relationship between S.P.L. and the input voltage is basically shown in the following formula:

$$\text{S.P.L. after increased input voltage (dB)} = \text{previous S.P.L.} + 20 \log(V_2/V_1)$$

V1: previous input voltage  
 V2: increased input voltage

Therefore, S.P.L. is theoretically getting 6dB larger as the input voltage is twice larger.

Fig. 10 represents S.P.L. - frequency characteristics for PKLCS1212E4001-R1 in which the input voltage is varied. We can see that S.P.L. is approximately getting 6dB larger as the input voltage is twice larger.

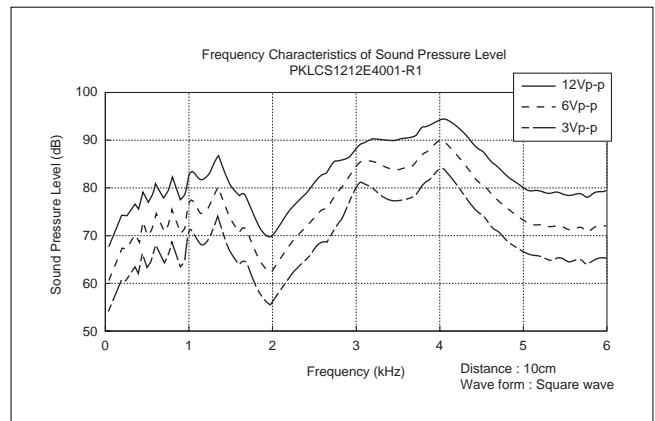

Fig. 10 Frequency Characteristics of Sound Pressure Level

## Procedures 2

In summary, the following are typical examples of raising S.P.L.

- ① (i), (ii), (iii) in Fig. 6, input D.C. voltage for Piezoelectric sound components should be getting larger.  
Variable range of input voltage should be less than Maximum input voltage.
- ② (i), (ii), (iii) in Fig. 6, the resistor that is connected in parallel should be changed to a booster coil (approx. 20-50mH).
- ③ In case that is driven by IC directly like as Fig. 11, input voltage of Piezoelectric sound components should be twice larger by BTL (Bridge Tied Load) drive circuit Involved an inverter.

In addition to the previous methods based on the electrical circuit, it is also possible for Piezoelectric sound components to raise up S.P.L. by using a resonant cavity based on Helmholtz's Formula in Fig. 4 of Page 3. Concerning these items, please feel free to contact the sales division.

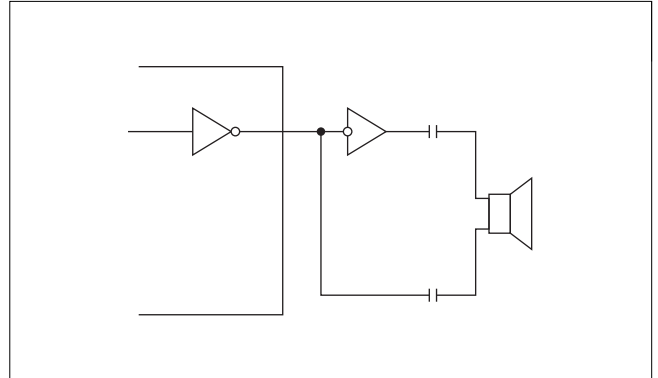

Fig. 11 Example of BTL Drive Circuit by 1-port Output IC for Buzzer

# 3 Characteristics and Measuring Method

## 1. Characteristics

Type	Resonant Frequency	Resonant Impedance	Capacitance	Sound Pressure Level	Oscillating Frequency	Current Consumption	Input Voltage	Operating Voltage
Piezoelectric Diaphragm	○	○	○					
Piezoelectric Sounder (External Drive)			○	○			○	
Piezoelectric Sounder (Self Drive)				○	○	○		○
Piezoelectric Buzzer				○	○	○		○
Remarks	Common Conditions : Operating Temp. Range / Storage Temp. Range Measurement Instruments : LCR Meter (Capacitance) / Freq. Counter (Oscillating Freq.) Multi Meter (Current Consumption)							

## 2. Measuring Procedure

### Measurement of Resonant Frequency and Resonant Impedance

When the piezoelectric diaphragm oscillates freely in air, the node does not move as shown in Fig. 12. With this point held with a measuring terminal, the resonant frequency ( $f_0$ ) and resonant impedance ( $R_0$ ) are measured in the constant-current circuit as shown in Fig. 13.

#### Measuring Procedure

- 1) Connect the switch to side "a" and adjust frequency of the oscillator to read the frequency and the voltage when the voltmeter indicates a minimum value.
- 2) Next connect the switch to side "b" and vary the variable resistor to have the same voltage as in 1). Then, read the value of the resistor.
- 3) The resonant frequency ( $f_0$ ) can be obtained from 1) and the resonant impedance ( $R_0$ ) from 2).

\*: Actual measurement is performed using a measuring unit in accordance with the above principles.

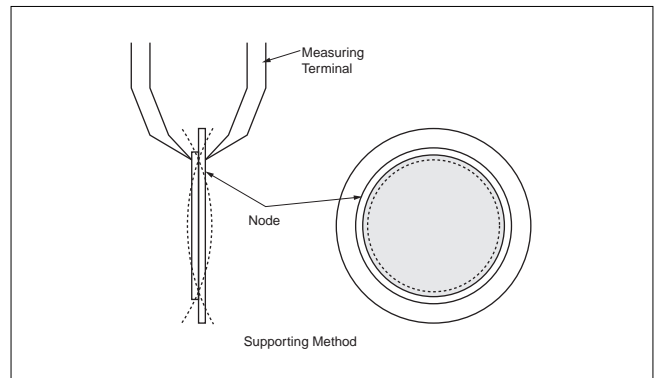

Fig. 12 Measurement of Piezoelectric Diaphragm

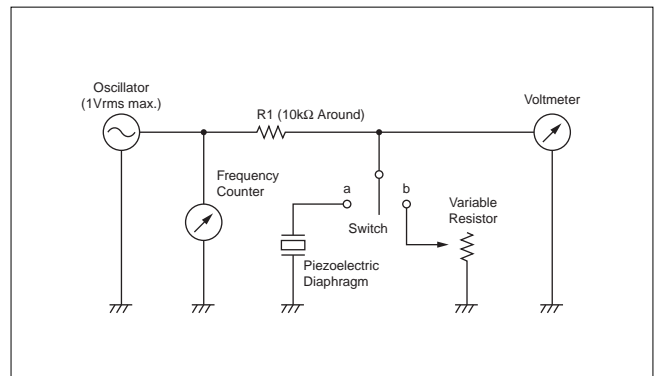

Fig. 13 Measurement Set Up of Resonant Freq. and Resonant Impedance

## Characteristics and Measuring Method 3

### Measurement of Sound Pressure Level (S.P.L.)

The sound pressure level is measured with a sound pressure level meter as shown in Fig. 14 (Fig. 14 shows an example of the self drive piezoelectric sounder).

\*: The relation between sound pressure level and distance, between sound pressure level and voltage can be expressed with Formula (2). The value of the sound pressure level under different operating conditions can be easily calculated using values specified in the catalog.

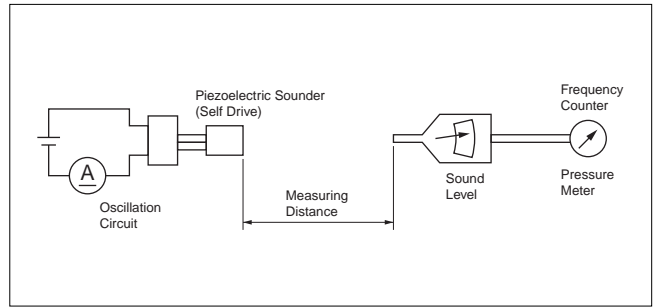

Fig. 14 Measurement Set Up of S.P.L.

$$\begin{aligned}
 & \text{S.P.L. (dB) [under actual operating conditions]} \\
 & = \text{S.P.L. (dB) [value specified in catalog]} \\
 & \quad - 20 \log A/B \text{ (dB)} \dots\dots\dots(2)
 \end{aligned}$$

- In case of relation with distance:
- A = Actual distance
  - B = Distance specified in catalog
- In case of relation with voltage:
- A = Voltage specified in catalog
  - B = Actual operating voltage

# 4 Environmental Characteristics

Various environmental changes such as change in room temperature, atmosphere and vibration should be considered at storage installation and actual operation of the piezoelectric buzzer. Typical voltage and temperature characteristics and environmental tests are shown using the piezoelectric sounder PKM24SPH3805 as an example.

## 1. Voltage and Temperature Characteristics

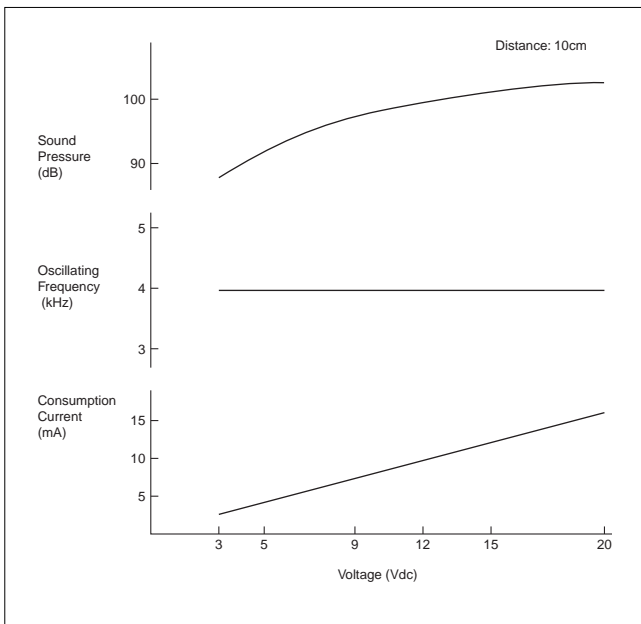

Fig. 15 Voltage Characteristics

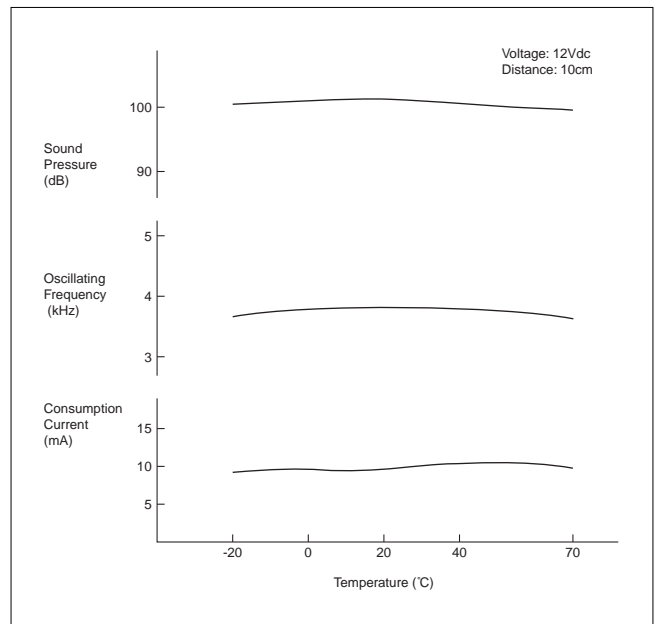

Fig. 16 Temperature Characteristics

## 2. Environmental Tests

No	Item	Condition	Deviations
1	High Temperature	+85±2°C, 240 Hrs.	S.P.L. : Initial value ±10dB Oscillating freq.: Initial value ±10% Consumption current: Initial value ±10%
2	Low Temperature	-40±2°C, 240 Hrs.	
3	Humidity	+60±2°C, R.H. 90-95%, 240 Hrs.	
4	Temperature Cycle	Following cycle 5times; -40±2°C (30 min.) → +20°C (15 min.) → +85±2°C (30 min.) → +20°C (15 min.)	
5	Vibration	10 to 55Hz (1 cycle, 1 min.) Amplitude 1.5 mm 2 Hrs for each three mutually perpendicular directions	
6	Shock	+100G sine wave 3 times for each three mutually perpendicular direction	

After following test, samples should be left in a natural condition (Temp. 25°C) for more than 4 hours.

**Note:**

1. Export Control

〈For customers outside Japan〉

No muRata products should be used or sold, through any channels, for use in the design, development, production, utilization, maintenance or operation of, or otherwise contribution to (1) any weapons (Weapons of Mass Destruction (nuclear, chemical or biological weapons or missiles) or conventional weapons) or (2) goods or systems specially designed or intended for military end-use or utilization by military end-users.

〈For customers in Japan〉

For products which are controlled items subject to the "Foreign Exchange and Foreign Trade Law" of Japan, the export license specified by the law is required for export.

2. Please contact our sales representatives or product engineers before using the products in this catalog for the applications listed below, which require especially high reliability for the prevention of defects which might directly damage a third party's life, body or property, or when one of our products is intended for use in applications other than those specified in this catalog.

- |                             |  |
|-----------------------------|--|
| ① Aircraft equipment        | ② Aerospace equipment  |
| ③ Undersea equipment        | ④ Power plant equipment  |
| ⑤ Medical equipment         | ⑥ Transportation equipment (vehicles, trains, ships, etc.)   |
| ⑦ Traffic signal equipment  | ⑧ Disaster prevention / crime prevention equipment   |
| ⑨ Data-processing equipment | ⑩ Application of similar complexity and/or reliability requirements to the applications listed above |

3. Product specifications in this catalog are as of July 2007. They are subject to change or our products in it may be discontinued without advance notice. Please check with our sales representatives or product engineers before ordering. If there are any questions, please contact our sales representatives or product engineers.

4. Please read rating and **CAUTION** (for storage, operating, rating, soldering, mounting and handling) in this catalog to prevent smoking and/or burning, etc.

5. This catalog has only typical specifications because there is no space for detailed specifications. Therefore, please approve our product specifications or transact the approval sheet for product specifications before ordering.

6. Please note that unless otherwise specified, we shall assume no responsibility whatsoever for any conflict or dispute that may occur in connection with the effect of our and/or a third party's intellectual property rights and other related rights in consideration of your use of our products and/or information described or contained in our catalogs. In this connection, no representation shall be made to the effect that any third parties are authorized to use the rights mentioned above under licenses without our consent.

7. No ozone depleting substances (ODS) under the Montreal Protocol are used in our manufacturing process.