

## 2 Example of Noise Suppression in Notebook PCs

### Noise Suppression in LCD

The connection between the graphic controller and LCD driver contains many lines that switch on and off simultaneously. This switching creates instantaneous large current flows into the GND and power supply line. Therefore, it is necessary to suppress the current flow from the signal lines. The BLM series (Chip Ferrite Bead) is typically used for this purpose. On the clock line, especially at high operating speeds and high noise levels, a filter with high and steep attenuation is used, such as the NFW31S series (Chip EMIFIL<sup>®</sup> for signal lines).

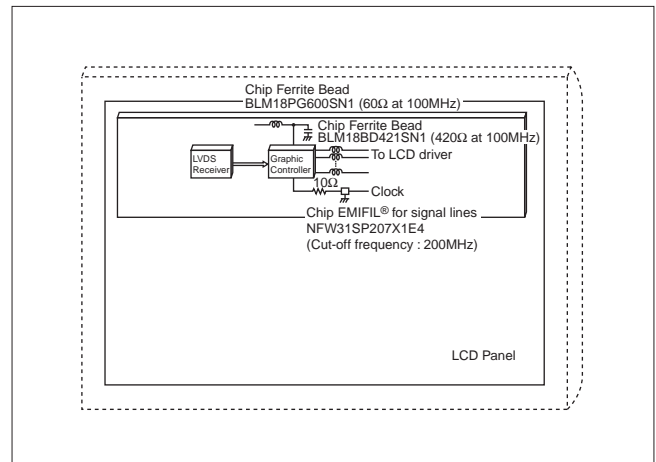

### Installing EMI filters on Interface Cable Ports

On the lines to the interface cable, three terminal capacitor the NFM21C series and Chip Ferrite Bead BLM series are generally installed in combination. In some cases, the EMIFIL<sup>®</sup> for signal lines is used. It is important to design the circuitry to minimize the high frequency impedance between the EMI filter's GND and the metal plate.

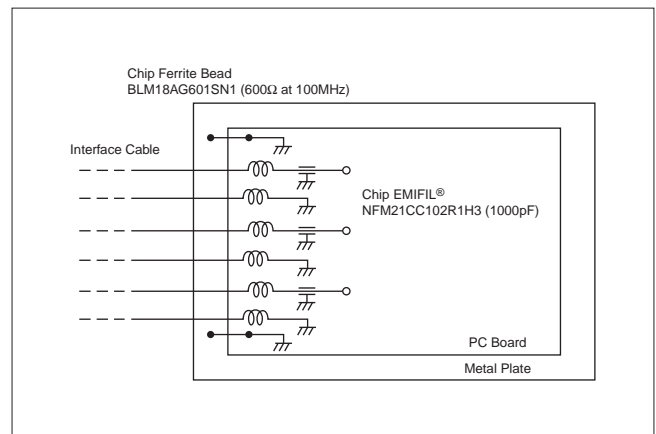

### Installing EMI Filters on the DC Power Supply Input

Since noise is radiated from the DC power supply cable of the AC adapter, some noise suppression is necessary at input to DC power supply of personal computer. The DC power supply line contains both differential mode noise and common mode noise. Both mode noises need to be suppressed.

The GND and metal plate are first connected together. The NFM55P series (Chip EMIFIL<sup>®</sup>) and the BLM□□P series (Chip Ferrite Bead) are used for differential mode noise suppression. The DLW5BS/AH series (Chip Common Mode Choke Coil) is used for common mode noise suppression.

