



Murata's High-Speed DC/DC Converter Tames Fast Load Transient

Data communication equipment and intelligent household electric appliances use numerous data processing ICs such as digital signal processors (DSPs), field programmable gate arrays (FPGAs), and microprocessors. These ICs require low operating voltage (1.0 to 1.5V) and increased load current coupled with a reduction in power consumption and the improvement in efficiencies. In these ICs, a load current suddenly increases and decreases depending on a processing task. As a result, the output voltage of a DC/DC converter may fluctuate causing a system failure.

A feeding configuration at the Point of Load (POL) in which a DC/DC converter is placed just near the load is used to address such a problem. Moreover, various external capacitors are connected in parallel to achieve the low-impedance voltage source across a broad frequency range. To cope with such conditions, the necessity for a high-speed DC/DC converter with minimal output voltage variation in

response to the fast load transient, and an ability to maintain a low impedance in high frequency domain has increased.

Murata Manufacturing Co., Ltd. has developed a ripple detection control system that has the highest-level load transient response performance in the industry. The company has produced on a commercial scale the "ripple converter extreme" MPDRX series, which can maintain the required voltage precision even with lower external capacitors. Fig. 1 illustrates the outside dimensions of the converters.

The following paragraphs will discuss the features of the MPDRX series. Upcoming expansion of this lineup will be addressed as well.

Ripple Detection Control System

The ripple detection control system improves upon a previously established technique known as ripple converter. In the ripple converter system, self-oscillation is achieved based on the system's delay time. The original ripple converter system had

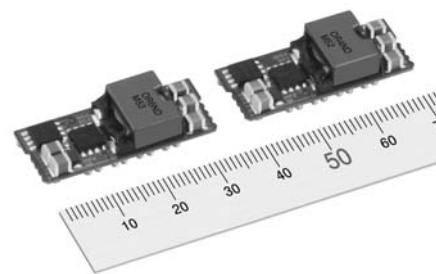

"Ripple converter extreme" MPDRX series

some performance issues to resolve though its response characteristics were excellent. First, the operating frequency remarkably decreases when a ceramic capacitor is used for the output capacitance. Second, the operating frequency varies depending on the presence of external capacitance.

Fig. 2 shows the principle drawing of a ripple detection control system. In the conventional pulse width modulation (PWM) control system that is generally used, there is a large delay in principle because the differential voltage between the output voltage and reference voltage is detected using an integrating circuit.

In a ripple detection system, a response delay can be made very small because an output voltage is directly compared with the reference voltage. Murata's unique

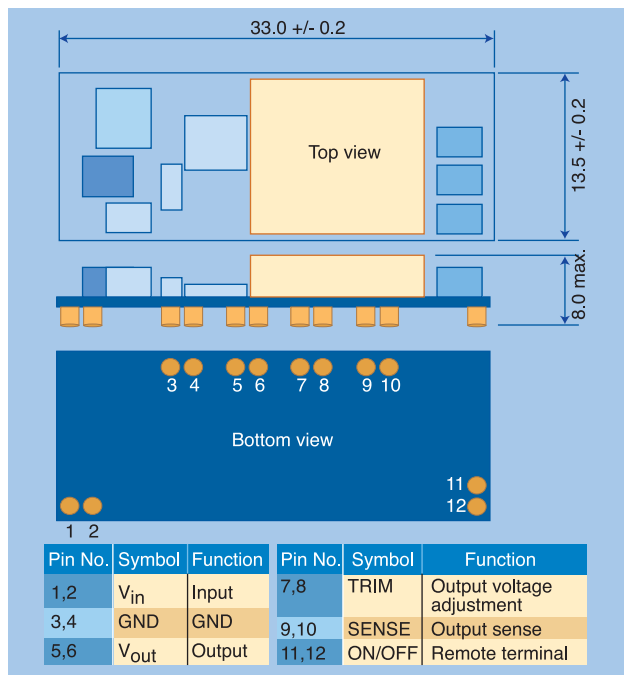

Fig. 1: Dimensions of MPDRX001S and MPDRX003S

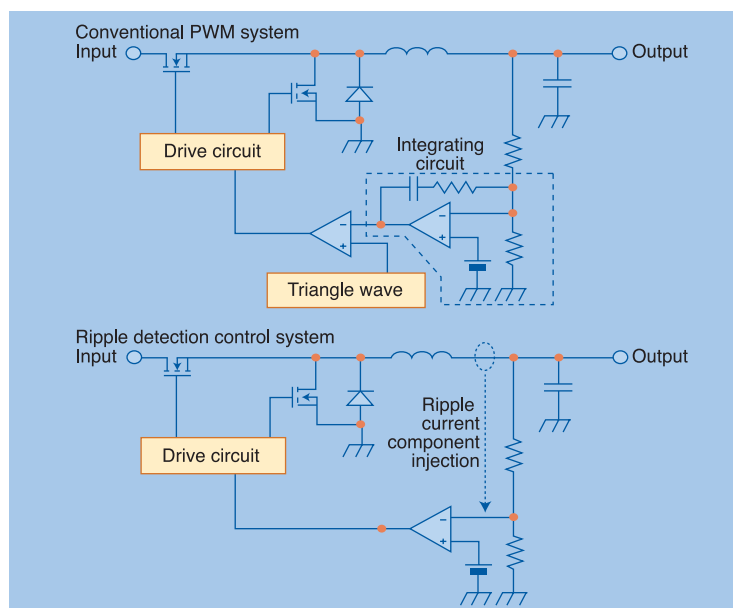

Fig. 2: Principle drawing of ripple detection control system

Table 1: Product specifications of “Ripple Converter Extreme”

	MPDRX001S	MPDRX003S
Dimensions	33 × 13.5 × 8.0mm	
Weight	5g (typ)	
Input voltage	4.5V~5.5V	10.8V~13.2V
Output voltage range	0.8V to 1.8V	
Output current	16A	12A
Static output voltage precision	±2.5%	
Voltage fluctuation during load transient	±40mV	±50mV
	Vo=1.8V, Io=50%→100%, Ta=25°C Cout=100uF, di/dt=2A/us	
Output ripple voltage	15mVpp(TYP)	
	Vo=1.8V, Io=MAX, BW=20MHz, Ta=25°C	
Conversion efficiency	90%	88%
	Vo=1.8V, Io=16A	
Operating temperature range	-40 to +85°C	

technology, which detects a current ripple component and AC-couples it to a feedback voltage, solves the problem occurring in the conventional ripple converter.

Introducing the MPDRX Series

The MPDRX001S has a 5V input and 0.8 to 1.8V, 16A output. The MPDRX003S has a 12V input and 0.8 to 1.8V, 12A output. These models conform to a de facto industry standard footprint and dimension of 33.0 × 13.5mm. Table 1 shows the product specifications.

Low voltage fluctuation

Fig. 3 compares the MPDRX001S and conventional products' voltage fluctuation during load transient. Fig. 3a shows a comparison of voltage fluctuations with an external capacitance of 100µF. With the MPDRX001S, the voltage fluctuation during a load transient is reduced to less than one-fourth that of conventional products. This shows that the likelihood of a system-failure event is markedly decreased when the IC's current consumption changes suddenly.

Fig. 3b highlights the result when the external capacitance of the conventional PWM device is increased until the voltage output variation achieves that of the MPDRX001S. With the MPDRX001S, the output voltage recovery time following a load transient is reduced to less than one-fifth, and the mounting area can be reduced substantially. Thus, the MPDRX series has a significant benefit when used for addressing large fluctuations in load.

Low output impedance

For data processing ICs, load fluctuates in a frequency of about 10Hz to 100kHz. A power source that keeps impedance sufficiently low in this frequency domain must be used. Fig. 4 shows the

result when the frequency dependence of the MPDRX001S' output impedance is compared with conventional products. When conventional products are used, the output impedance increases significantly between 1 and 100kHz. This implies the DC/DC converter's control loop cannot respond to fluctuations in this frequency range. Previously, in this frequency domain, impedance was decreased by connecting multiple capacitors (for example, aluminum electrolytic capacitors and ceramic capacitors) having different resonance frequencies in parallel.

With the MPDRX001S, output impedance does not rise until 100kHz is reached. This indicates that an electrolytic capacitor, which covers a low-frequency domain, can be eliminated. In other words, a low-impedance voltage source can be realized across a wide frequency range. This is partially enabled with a simple ceramic ca-

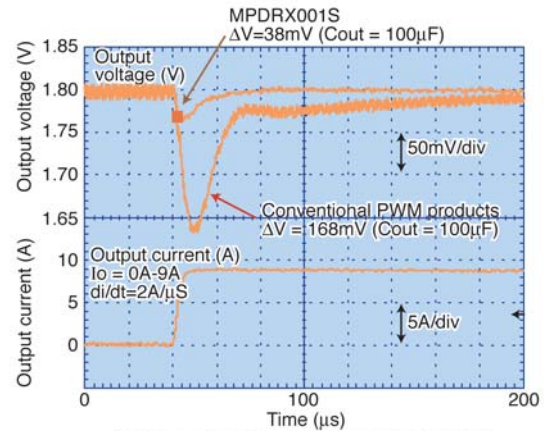

(a) Comparison in external capacity of 100µF

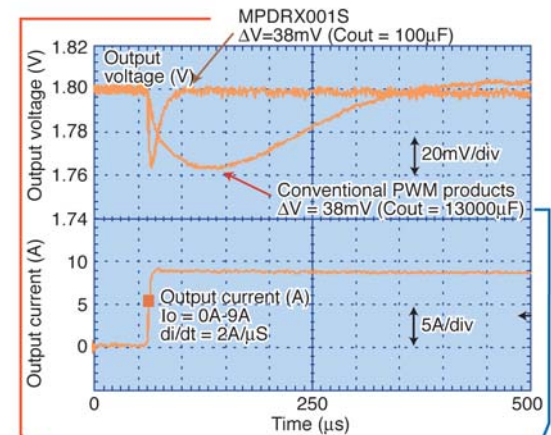

(b) When external capacity is increased so that ΔV is the same

Fig. 3: Comparison of voltage fluctuation during sudden change in load in MPDRX001S and conventional PWM products

pacitor to cover the high-frequency domain that the DC/DC converter is unable to track.

(Continued on page34)

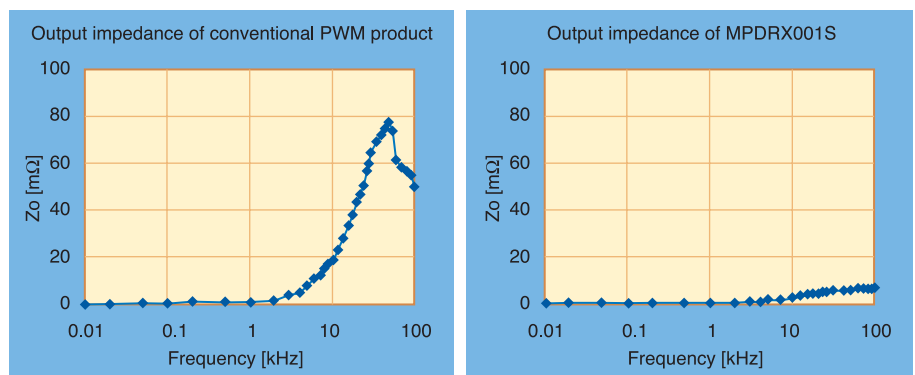

Fig. 4: Frequency characteristics of output impedance

Murata's High-Speed DC/DC Converter Tames...

(Continued from page 32)

High efficiency

Fig. 5 shows the efficiency comparison of high-speed products from other companies and Murata's MPDRX001S. The MPDRX001S maintains a high conversion efficiency though it features excellent characteristics during sudden load changes relative to other companies' products. The primary reason is that the operating frequency in the hundreds-of-kilo-hertz domain can be used because the control system is essentially based on a high-speed control.

Into The Future

Murata Manufacturing has developed

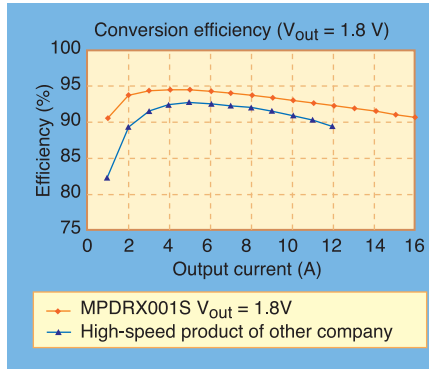

Fig. 5: Comparison of conversion efficiency

a ripple detection control system-based DC/DC converter. It is most suitable for

a low voltage, high current and load-current fluctuation required by DSPs, FPGAs, and microprocessors. The use of this product can reduce mounting area and decrease the possibility of system failure caused by insufficient regulation of power supply voltage. The company eyes the expansion of the lineup in terms of module shape, output current range, and input voltage range.

About This Article:

The author, Takashi Noma, is Chief of Product Development Section 2, Power Device Products Division, Murata Manufacturing Co., Ltd.