

Low Profile Isolated DC-DC Converter Application Manual

MPD6D12_S Series

Murata Manufacturing Co., Ltd
Product Development Section
Power Supply Modules Department

⚠Note • Please read rating and ⚠CAUTION (for storage, operating, rating, soldering, mounting and handling) in this catalog to prevent smoking and/or burning, etc.
• This catalog has only typical specifications because there is no space for detailed specifications. Therefore, please approve our product specifications or transact the approval sheet for product specifications before ordering.

1. Features

- 1-1 Ultra Low Profile (45.0 × 45.0 × 4.2mm Typ.) SMD
- 1-2 High efficiency and High power density achieved via Murata proprietary synchronous rectifier circuit.
- 1-3 Wide Operating Temperature Range (-40 to +85 degreeC)
- 1-4 Wide Input Range 36 to 75V
- 1-5 Up to 10 Devices in Parallel Operation
- 1-6 Input to Output Isolation: 1.5kV (DC) for One Minute
- 1-7 Built-In Over Current Protection, Over Voltage Protection and Over Heating Protection
- 1-8 UL60950 Recognized, CE Marking (LVD and EMC Directive)

2. Product Line Up

2-1 TN30W Series

Nominal Output Voltage (V)	Part No.
1.2	MPD6D122S
1.5	MPD6D123S
1.8	MPD6D124S
2.5	MPD6D126S
3.3	MPD6D127S
5.0	MPD6D128S

3. Ratings

- 3-1 Operating Temperature Range -40 to +85 degreeC (Please refer to the temperature derating table.)
- 3-2 Operating Humidity Range 20 to 85%RH (No condensation)
- 3-3 Storage Temperature Range -45 to +90 degreeC
- 3-4 Storage Humidity Range 10 to 95%RH (No condensation)

4. Electrical Characteristics

4-1 Absolute Maximum Ratings

Items	Unit	Maximum	Remark	
Minimum Input Voltage	V	0		
Maximum Input Voltage	Time	Continuous	V	75
RC Pin Voltage				
ALM Pin Voltage	200us	V	90	Slew Rate : 42V/10us
PO Pin Voltage	V	8		
ALM Pin Maximum Sink Current	mA	10		

4-2 General Characteristics (Statics, Ambient Temperature: Ta=-40 to +85 degreeC)

Item	Unit	Value	Remark
Rated Input Voltage	V	48	
Input Voltage Range	V	36 to 75	With Natural Air Convection 0.2m/s (40LFM)
Turn-On Input Voltage	V	32.0 to 36.0	
Hysteresis Voltage	V	Minimum 2	Input Voltage Difference between Turn-on/off
Galvanic Isolation Voltage	Vdc	Minimum 1,500	For One Minute between Input and Output
EMC (Radiated EMI/Conduction)		In Accordance with CISPR Publication22, Class A (VCCI Class A)	Refer to Section 10. Measurement Setup
Safety Standards		UL60950 (UL/C-UL)	Recognized
CE Marking		Attached	Self-Declaration

▲Note • Please read rating and ▲CAUTION (for storage, operating, rating, soldering, mounting and handling) in this catalog to prevent smoking and/or burning, etc.
• This catalog has only typical specifications because there is no space for detailed specifications. Therefore, please approve our product specifications or transact the approval sheet for product specifications before ordering.

4-3 Output Characteristics Ta = -40 to 85 degreeC

Items	Model	MPD6D12_S						Unit
		122	123	124	126	127	128	
Nominal Output Voltage		1.2	1.5	1.8	2.5	3.3	5.0	V
Output Voltage Regulation Vin=36 to 75V Output Current Range=0 to 100%		+5, -3						%
Nominal Output Current		12	11	11	10	9	6	A
Output Current-Limit Inception	Min.	12.3	11.3	11.3	10.3	9.3	6.2	A
Over Voltage Protection Note 1	Min.	1.44	1.80	2.16	3.00	3.96	6.00	V
Low Voltage Protection Note 2	Max.	1.08	1.35	1.62	2.25	2.97	4.50	V
Efficiency (Typ.) Ta=25°C, Vin=48V, Nominal Output Current		84	86	88	90	91	92	%
Output Ripple and Noise	Max.	50 Note 3						mVp-p
Output Ripple	Max.	30 Note 3						mVp-p

Note 1: Output halted in latch-up mode after mask time 0.5ms (typ.), preventing DC-DC Converter from malfunction by external noise and/or transient output voltage change.

Note 2: Output halted in latch-up mode after mask time 500ms (typ.), preventing DC-DC Converter from malfunction by external noise and/or transient output current change.

Note 3: Refer to section 10. Measurement Setup.

5. Operation Information

5-1 Reset Condition

In order to reset all functions, the input voltage (Vin) must be set under 5V for 1s. min.

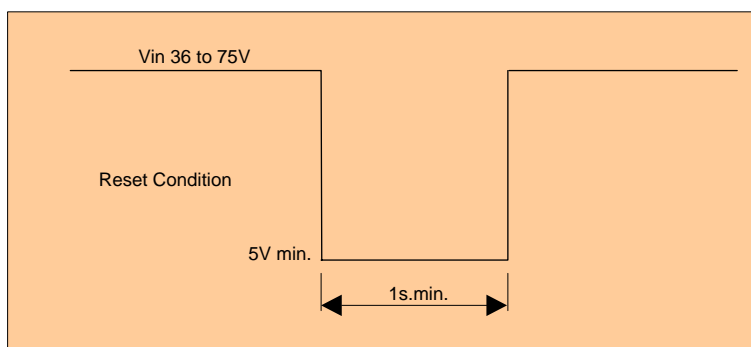

5-2 Over Voltage Protection (OVP)

The Isolated DC-DC Converter enters latch-up mode after typical 0.5ms. mask time, when the output voltage is over the value specified in Over Voltage Protection (Section 4-3) by failure of internal control circuit.

In order to reset, the input voltage must be set under 5V for 1s. min.

Output voltage might exceed the point at which OVP starts to function under conditions of transient input voltage or output current changes.

Therefore, OVP is set to wait for the mask time 0.5ms.

It is recommended to evaluate your appliances installed with the DC-DC Converter.

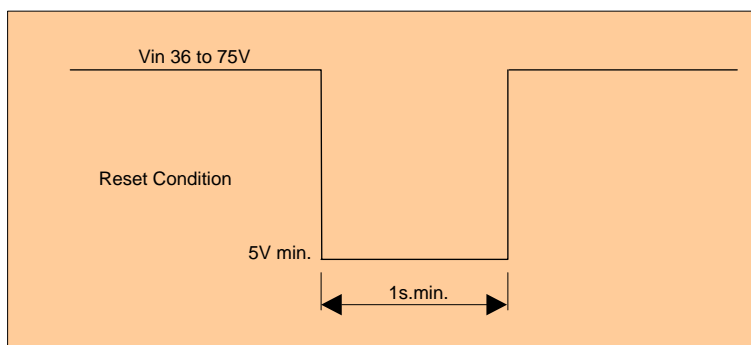

⚠Note • Please read rating and ⚠CAUTION (for storage, operating, rating, soldering, mounting and handling) in this catalog to prevent smoking and/or burning, etc.

• This catalog has only typical specifications because there is no space for detailed specifications. Therefore, please approve our product specifications or transact the approval sheet for product specifications before ordering.

5-3 Low Voltage Protection (LVP)

The Isolated DC-DC Converter enters latch-up mode after typical 500ms. mask time, when the output voltage is under the value specified in Low Voltage Protection (Section 4-3) by operating Over Current-Limit Inception due to failure of internal control or over load.

In order to reset, the input voltage must be set under 5V for 1s. min.

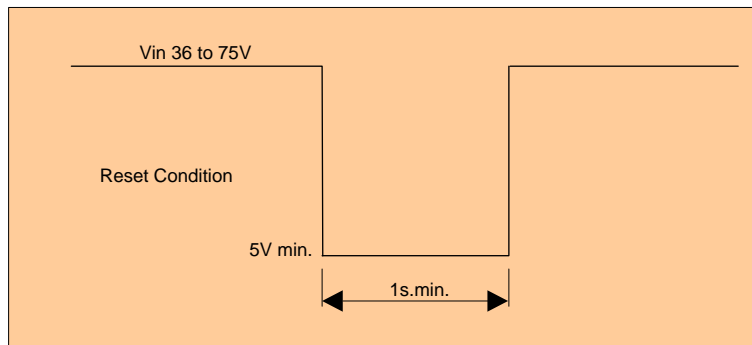

5-4 Remote On/Off Control

The connection to a RC pin controls an Isolated DC-DC Converter to turn on/off.

While the Isolated DC-DC Converter is halted via the remote control feature, the alarm function will not operate; refer to Alarm Output (Section 5-5).

Start: RC open or connected to -Vin

Halt: RC connected to +Vin

5-5 Alarm Output (ALM)

The Alarm Output can be down to the level of -Vin (Open Drain Output), when Over Voltage Protection or Low Voltage Protection features are activated. The sink current in ALM pin is 10mA max. Multiple Isolated DC-DC Converters running independently and/or in parallel operation can be simultaneously halted by connecting all ALM pins, when the Over Voltage Protection or Low Voltage Protection functions are activated by any single DC-DC Converter. The maximum number connected running DC-DC Converters is 10pcs.

To connect more than 10, please consult Murata.

5-6 Synchronous Turn-On/Off

Multiple Isolated DC-DC Converters running independently and/or in parallel operation can be synchronously toggled on/off timing among the running converters, of which the input voltage detection circuits are tied to the detection voltage of a single reference Isolated DC-DC Converter. Every PO pin must be connected for multiple and/or parallel operation. The Maximum number connected running DC-DC Converters is 10pcs.

To connect more than 10, please consult Murata.

6. Parallel Operation

6-1 Parallel Operation Description (Current Sharing)

When the output current required is more than that available from one DC-DC Converter an alternative to choosing a higher power rated DC-DC Converters is to operate multiple DC-DC Converters in parallel.

It is possible to run up to 10 DC-DC Converters in parallel operation.

Combining different Murata model devices with identical output voltages (designed for telecomm/datacomm equipment) is possible. To optimize this feature all PO pins should be connected so that the turn-on/off of all connected DC-DC Converters are synchronized. Additionally connecting the ALM pins of the devices in parallel operation enables simultaneous shut down of all DC-DC Converters when one is halted and generates an ALM signal due to an OVP or LVP condition.

Note • Please read rating and **CAUTION** (for storage, operating, rating, soldering, mounting and handling) in this catalog to prevent smoking and/or burning, etc.

• This catalog has only typical specifications because there is no space for detailed specifications. Therefore, please approve our product specifications or transact the approval sheet for product specifications before ordering.

6-2 Load Balance in Parallel Operation

No external load balancing circuit or reverse-current prevention circuit is necessary for Murata's DC-DC Converters operating in parallel. Murata's DC-DC Converters are designed to regulate load balancing and prevent reverse-current.

The combined devices operated in parallel provide an output voltage within the tolerance specified for either device (e.g. +5/-3%). This tolerance is maintained throughout the output current variance from zero to the rated current value. This feature automatically balances the output currents from all of the parallel DC-DC Converters.

7. Appearance and Dimensions

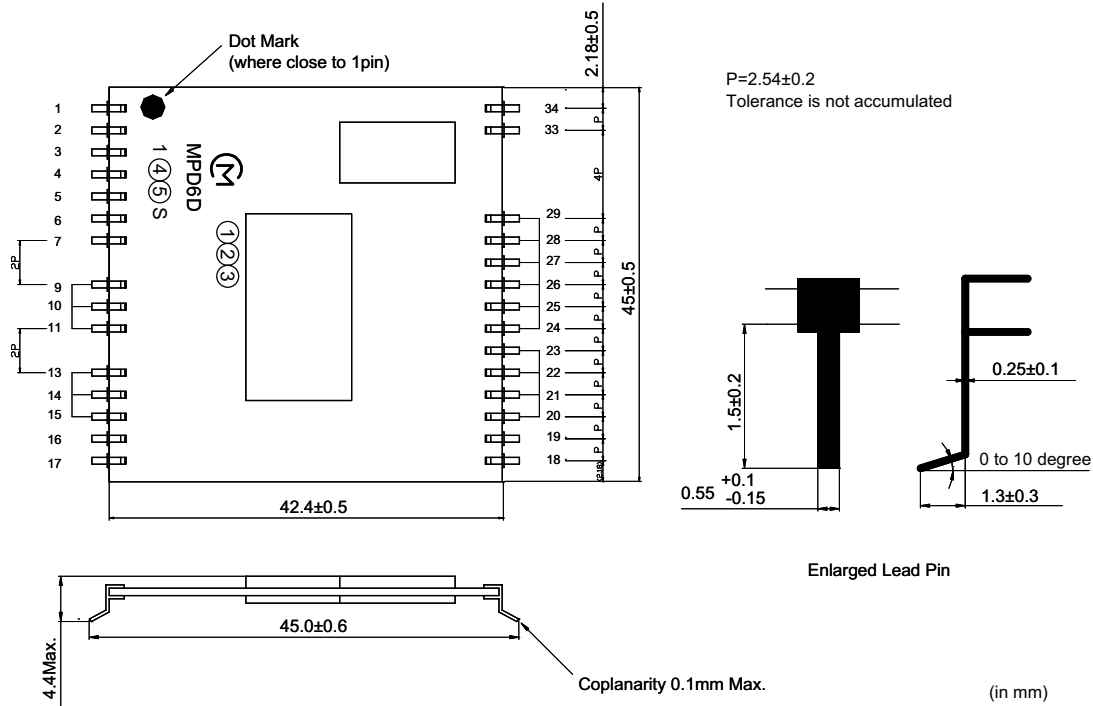

Marking

Part Number

MPD6D12_S

Murata CM Mark



Lot Number

- ① Factory symbol
- ② The last number of production year. Example: 2 stands for 2002
- ③ Production month. Example: 1 stands for January
 -
 - 9 stands for September
 - O stands for October
 - N stands for November
 - D stands for December

④ 22,23,24,26,27,28 which is __ of MPD6D1__S

⚠Note • Please read rating and ⚠CAUTION (for storage, operating, rating, soldering, mounting and handling) in this catalog to prevent smoking and/or burning, etc.
 • This catalog has only typical specifications because there is no space for detailed specifications. Therefore, please approve our product specifications or transact the approval sheet for product specifications before ordering.

Pin Number and Function

Pin No.	Pin Symbol	Function
1,2,4,6,16,17,18,19,33,34	NC	Not Connected Note 1
3	ALM	Alarm Note 2
5	RC	Remote On/Off Control
7	PO	Parallel Operation Note 3
9,10,11	-Vin	-Input
13,14,15	+Vin	+Input
20,21,22,23	+Vout	+Output
24,25,26,27,28,29	-Vout	-Output

Note 1: It is recommended that pins at the four corners of the substrate be bonded to the assembly board with a thermal setting resin when DC-DC Converters are mounted on the assembly board's underside. Otherwise DC-DC Converters may fall from the assembly board during the secondary reflow process.

Note 2: Any DC-DC Converter halted by abnormal operation forces all DC-DC Converters, connected via ALM pins for parallel and/or multiple operation, to discontinue operation.

Note 3: DC-DC Converters connected via PO pins can start via synchronized timing for parallel and/or multiple operation.

8. Recommendable Solder Land Pattern

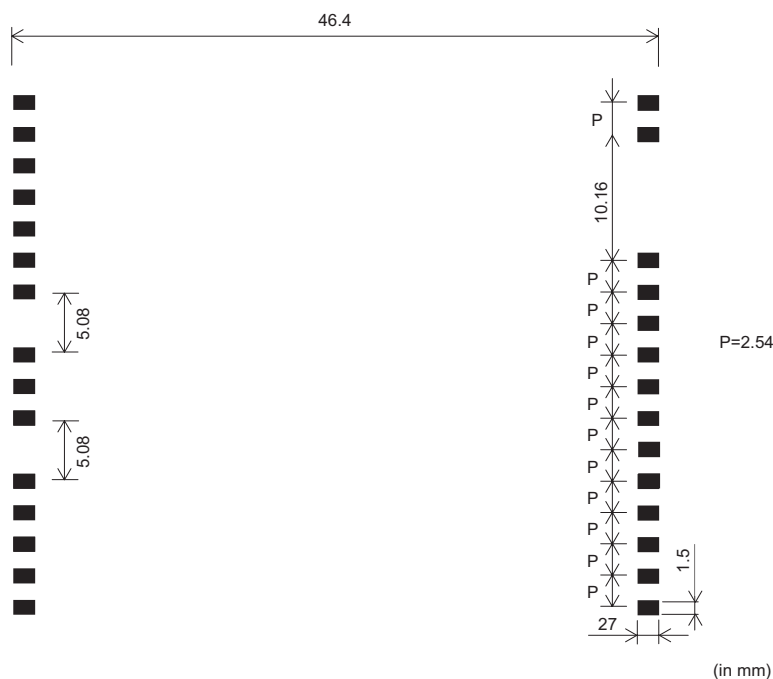

⚠Note • Please read rating and ⚠CAUTION (for storage, operating, rating, soldering, mounting and handling) in this catalog to prevent smoking and/or burning, etc.

• This catalog has only typical specifications because there is no space for detailed specifications. Therefore, please approve our product specifications or transact the approval sheet for product specifications before ordering.

9. Typical Power Derating

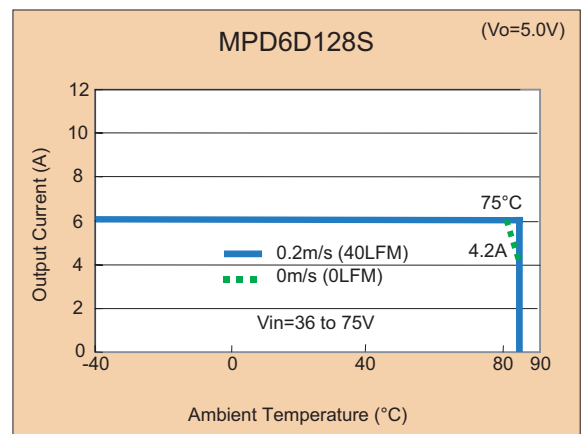
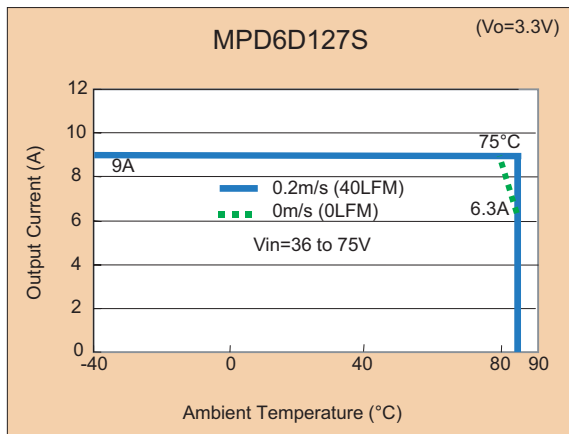
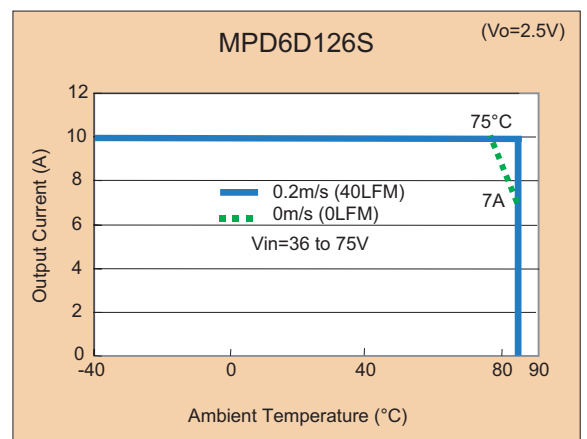
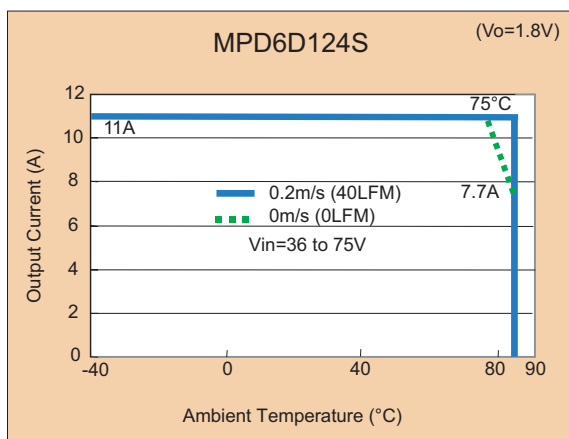
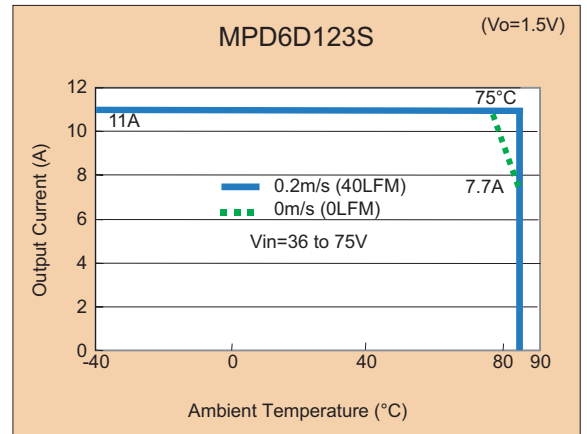
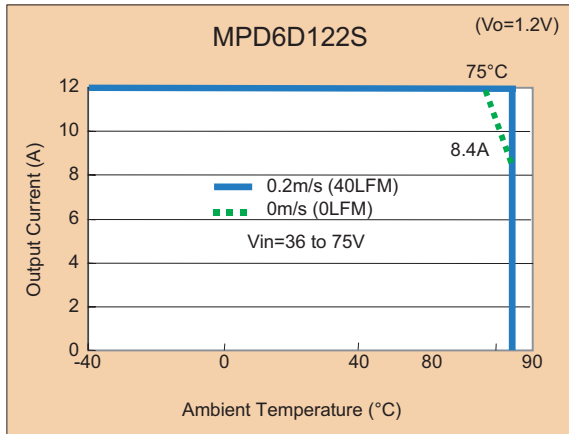

⚠ Note • Please read rating and ⚠ CAUTION (for storage, operating, rating, soldering, mounting and handling) in this catalog to prevent smoking and/or burning, etc.
 • This catalog has only typical specifications because there is no space for detailed specifications. Therefore, please approve our product specifications or transact the approval sheet for product specifications before ordering.

10. Measurement Setup

Please follow the below indicated connections when measurements are conducted.
 Otherwise measured values may deviate from the specifications.

10-1 General Measurement Circuit

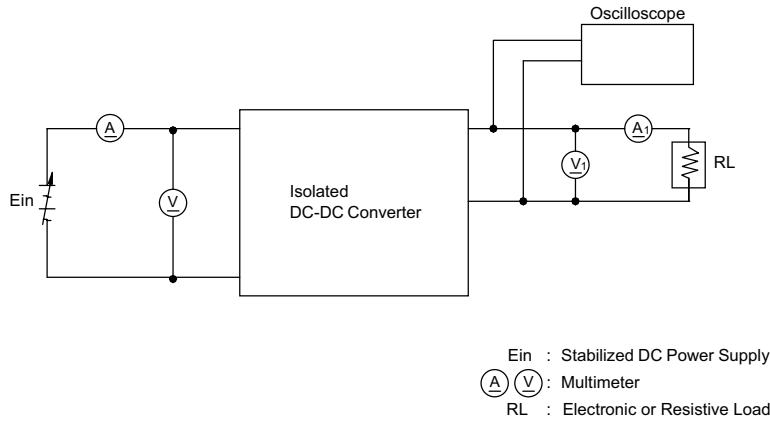

10-2 Output Ripple and Noise

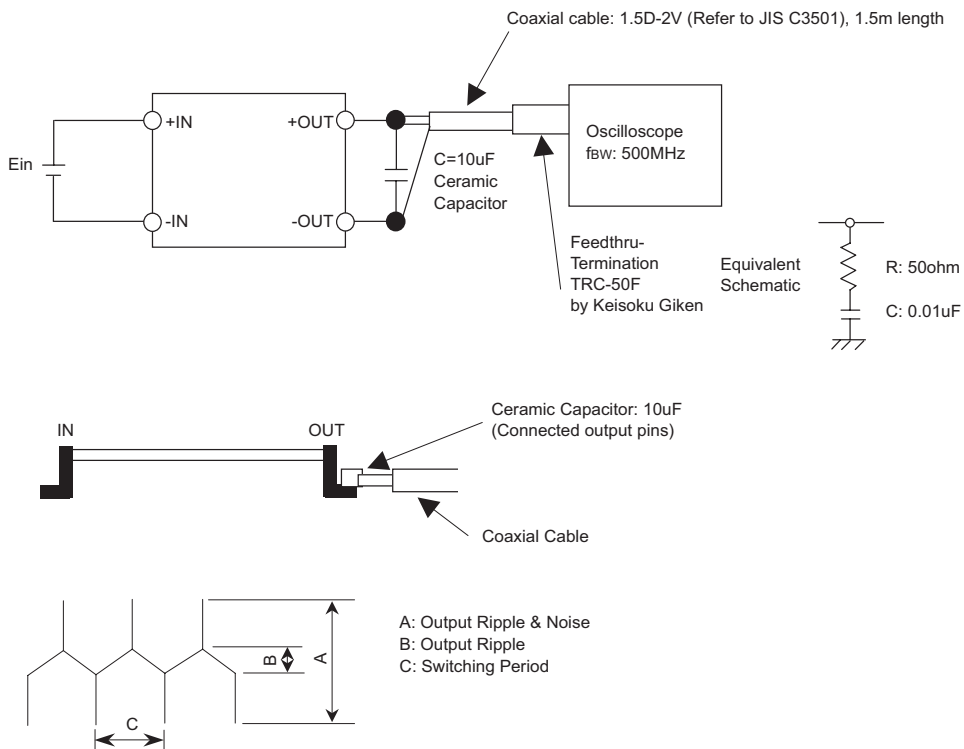

⚠Note • Please read rating and ⚠CAUTION (for storage, operating, rating, soldering, mounting and handling) in this catalog to prevent smoking and/or burning, etc.
 • This catalog has only typical specifications because there is no space for detailed specifications. Therefore, please approve our product specifications or transact the approval sheet for product specifications before ordering.

10-3 Radiated EMI and Conduction Noise

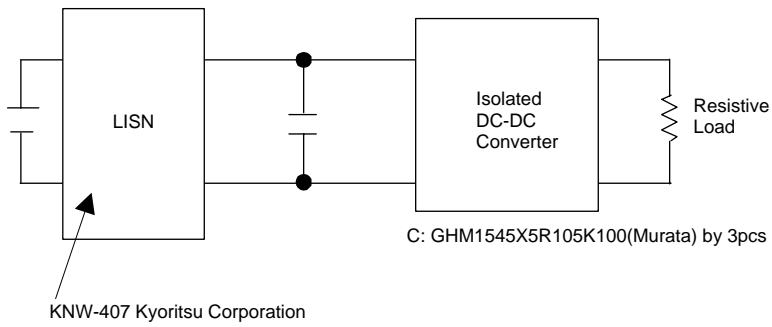
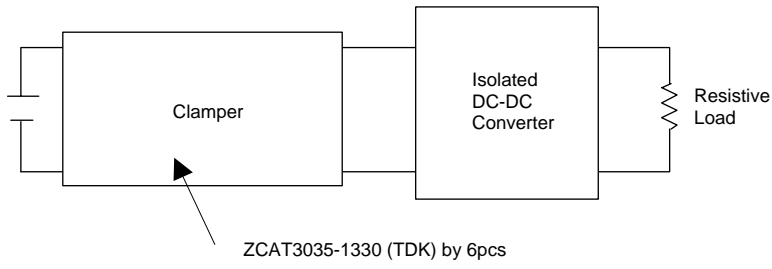

⚠Note • Please read rating and **⚠CAUTION** (for storage, operating, rating, soldering, mounting and handling) in this catalog to prevent smoking and/or burning, etc.
• This catalog has only typical specifications because there is no space for detailed specifications. Therefore, please approve our product specifications or transact the approval sheet for product specifications before ordering.

11. Characteristics Data

Fig.11-1 to Fig.11-4 expresses the standard characteristic of MPD6D12_S series (Ta=25 degreeC).

11-1 MPD6D122S (1.2Vout) Characteristics Data (Ta=25 degreeC, Cout: None)

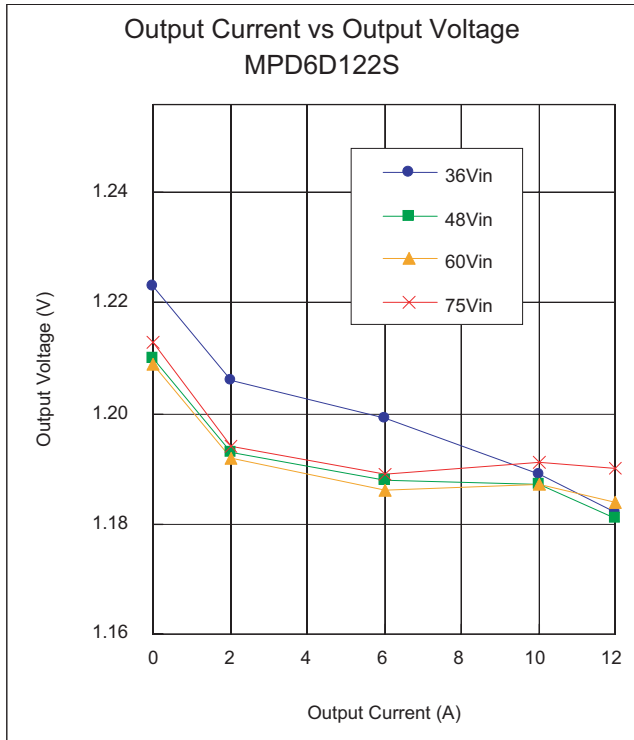

Fig.11-1-1. Output Voltage vs Output Current

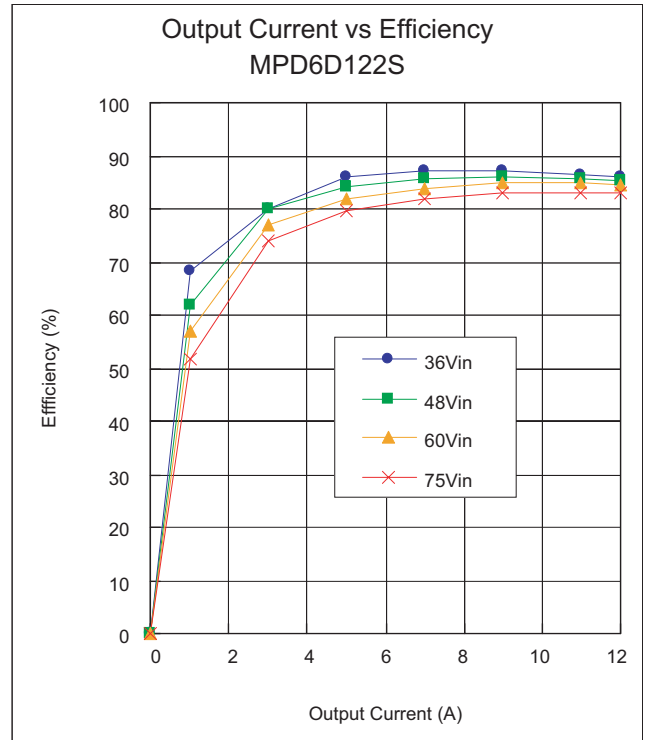

Fig.11-1-2. Efficiency vs Output Current

11-2 MPD6D123S (1.5Vout) Characteristics Data (Ta=25 degreeC, Cout: None)

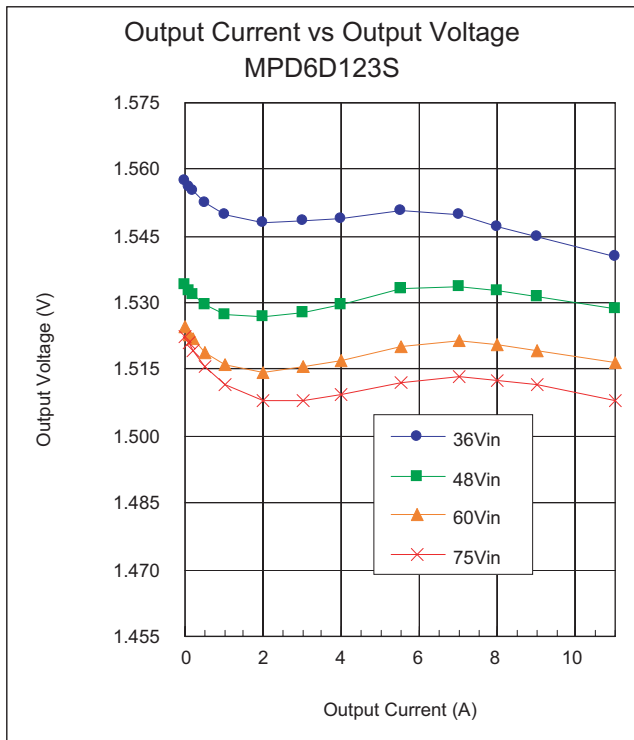

Fig.11-2-1. Output Voltage vs Output Current

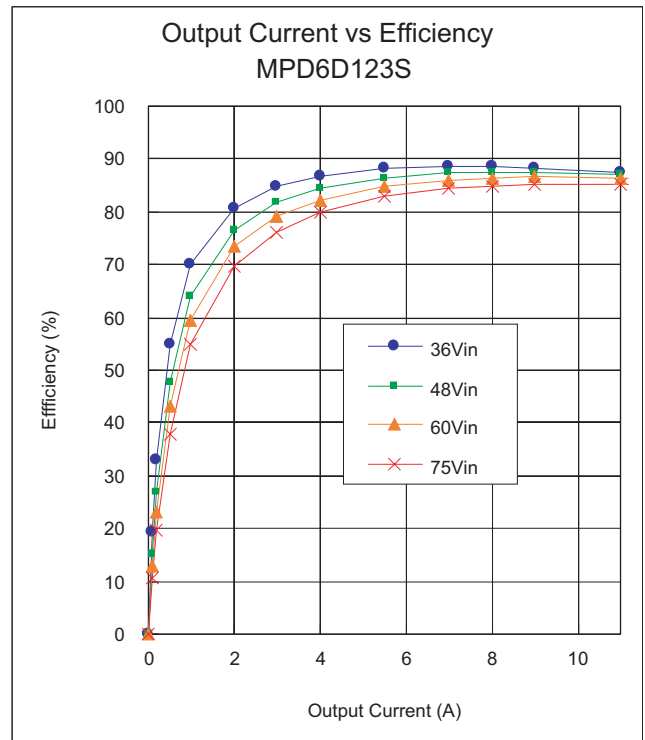

Fig.11-2-2. Efficiency vs Output Current

▲Note • Please read rating and ▲CAUTION (for storage, operating, rating, soldering, mounting and handling) in this catalog to prevent smoking and/or burning, etc.
 • This catalog has only typical specifications because there is no space for detailed specifications. Therefore, please approve our product specifications or transact the approval sheet for product specifications before ordering.

11-3 MPD6D124S (1.8Vout) Characteristics Data (Ta=25 degreeC, Cout: None)

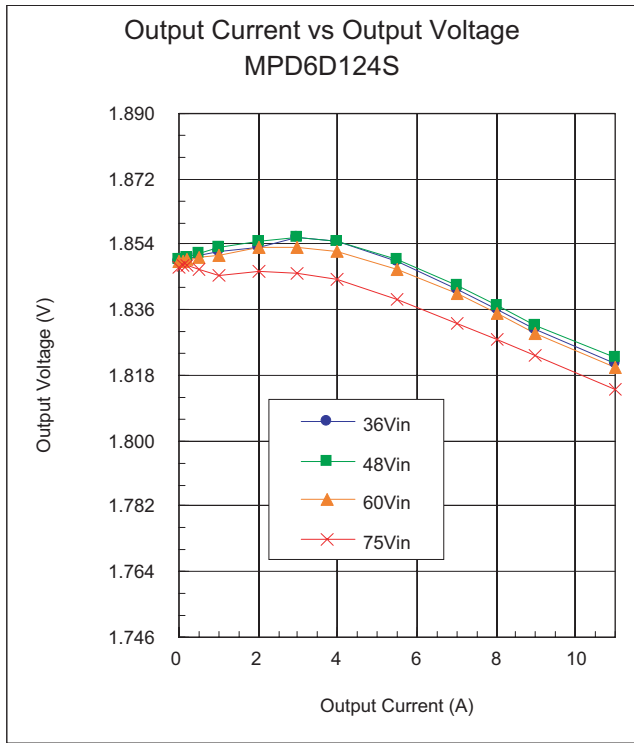

Fig.11-3-1. Output Voltage vs Output Current

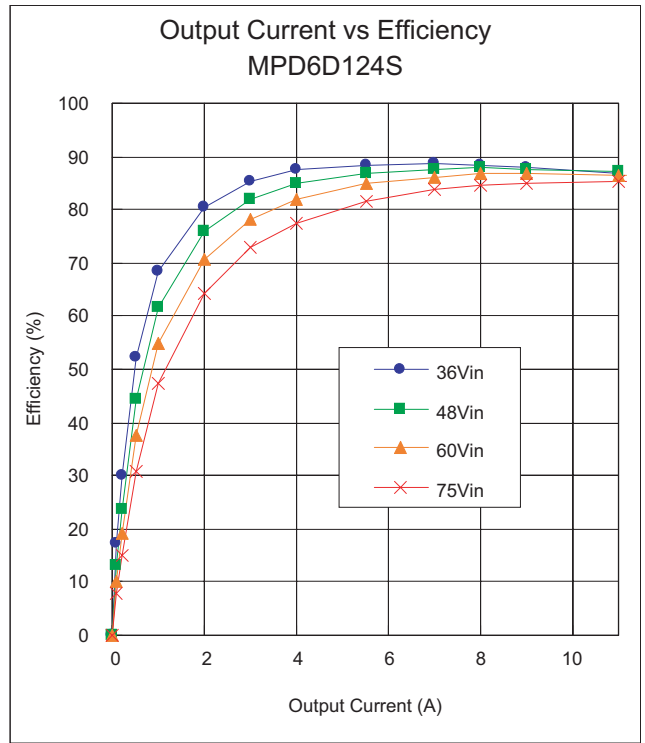

Fig.11-3-2. Efficiency vs Output Current

11-4 MPD6D126S (2.5Vout) Characteristics Data (Ta=25 degreeC, Cout: None)

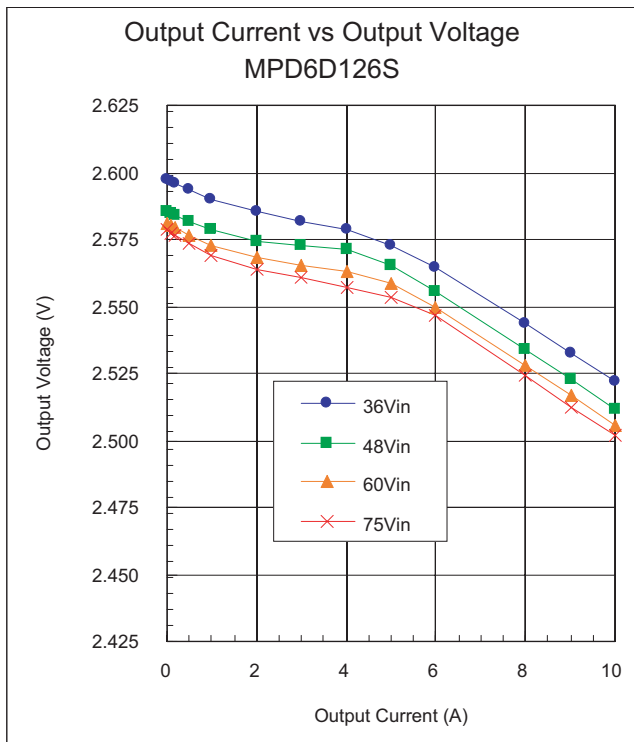

Fig.11-4-1. Output Voltage vs Output Current

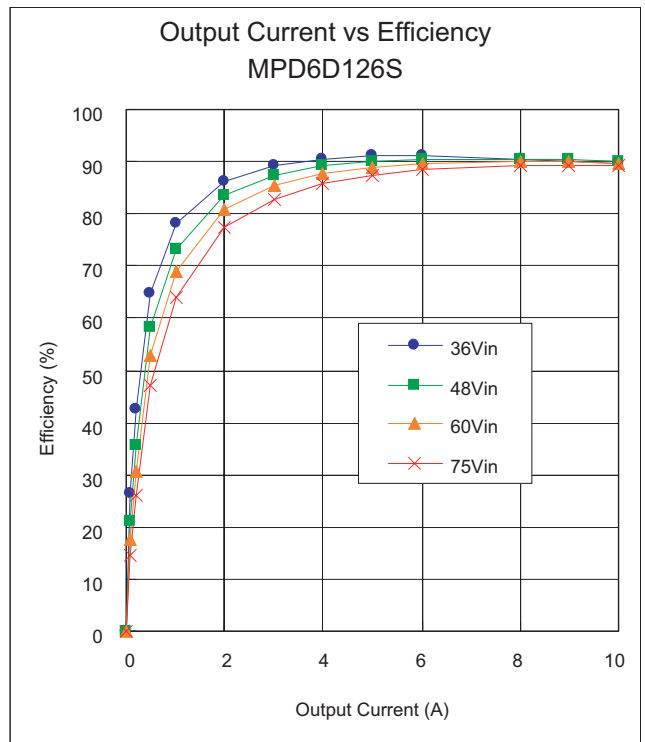

Fig.11-4-2. Efficiency vs Output Current

⚠ Note • Please read rating and ⚠ CAUTION (for storage, operating, rating, soldering, mounting and handling) in this catalog to prevent smoking and/or burning, etc.
 • This catalog has only typical specifications because there is no space for detailed specifications. Therefore, please approve our product specifications or transact the approval sheet for product specifications before ordering.

11-4 MPD6D127S (3.3Vout) Characteristics Data (Ta=25 degreeC, Cout: None)

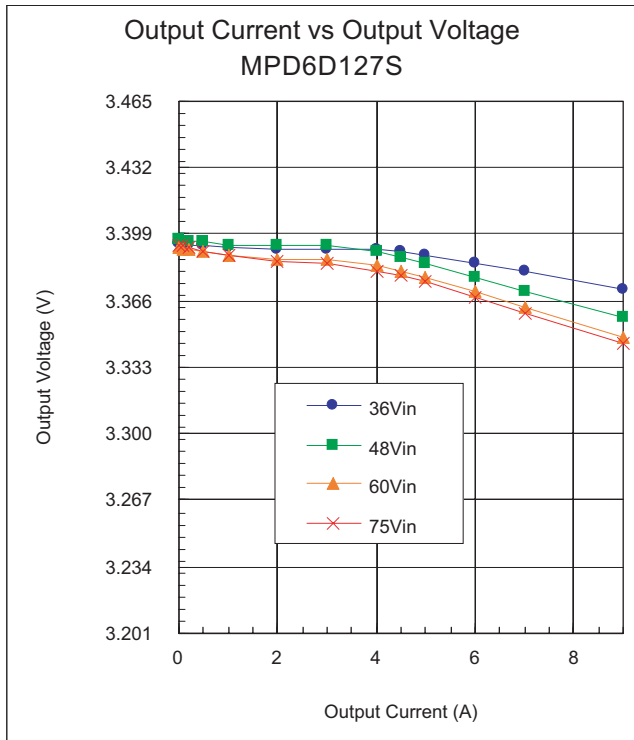

Fig.11-4-1. Output Voltage vs Output Current

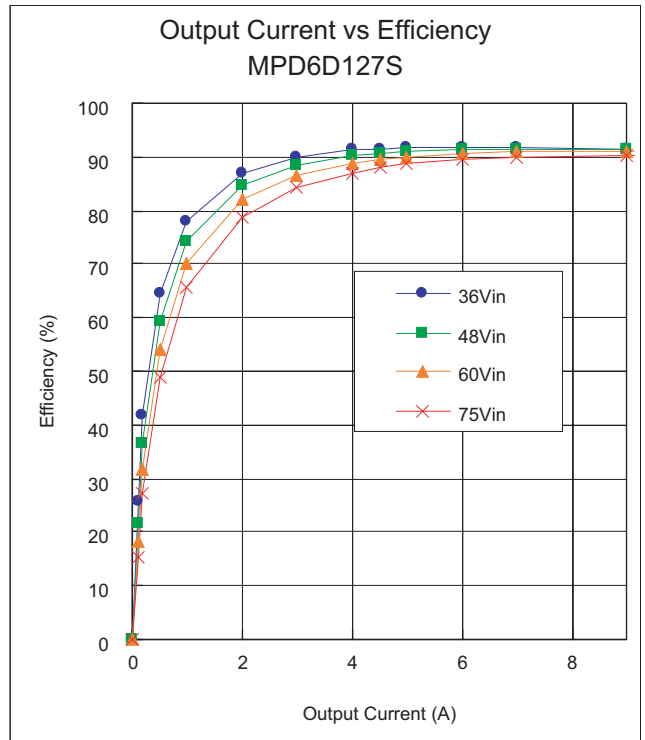

Fig.11-4-2. Efficiency vs Output Current

11-4 MPD6D128S (5.0Vout) Characteristics Data (Ta=25 degreeC, Cout: None)

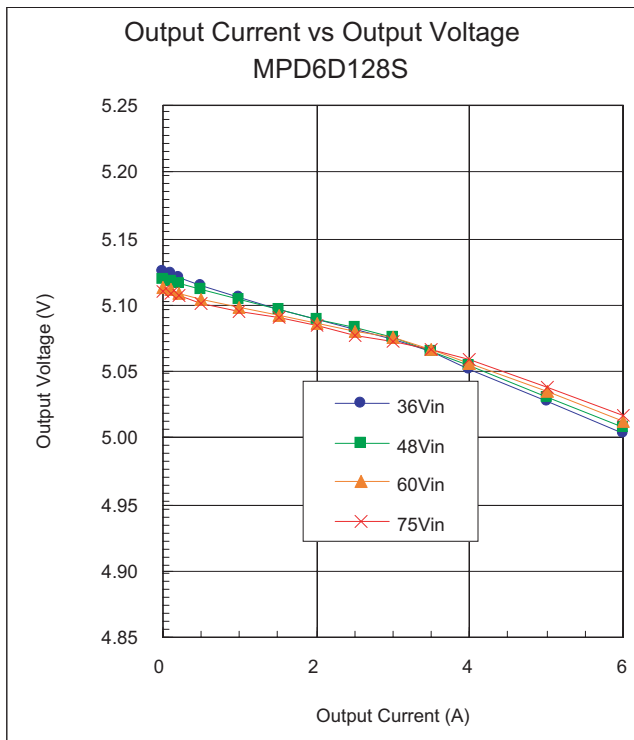

Fig.11-4-1. Output Voltage vs Output Current

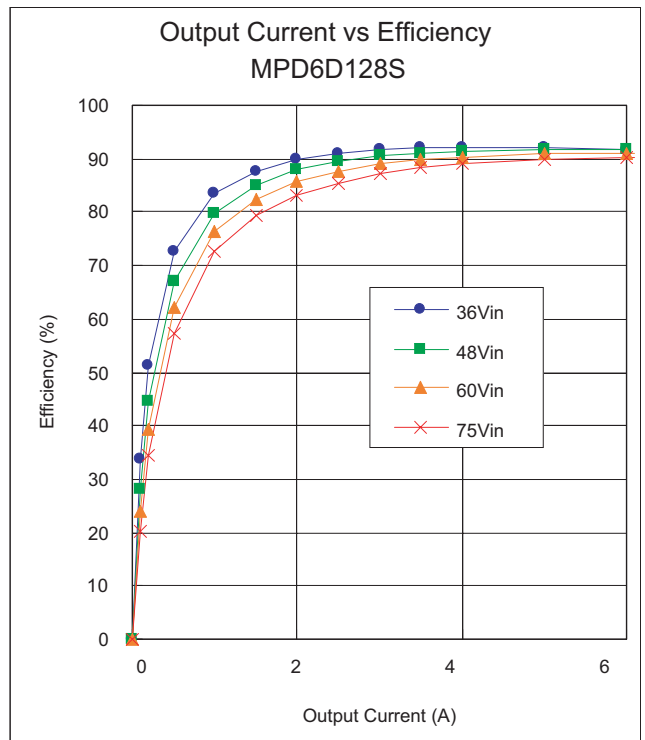

Fig.11-4-2. Efficiency vs Output Current

⚠ Note • Please read rating and ⚠ CAUTION (for storage, operating, rating, soldering, mounting and handling) in this catalog to prevent smoking and/or burning, etc.
 • This catalog has only typical specifications because there is no space for detailed specifications. Therefore, please approve our product specifications or transact the approval sheet for product specifications before ordering.

12. External Input-Output Capacitor

<External Input Capacitor>

When an inductance or a switch device are connected to the input line, or when the transient characteristics of the input power supply is unstable, the input voltage may be effected significantly by a sudden change of DC-DC Converter load.

Because the load response of the DC-DC Converter may not be adequately demonstrated by this influence, and the DC-DC Converter may cause unusual oscillations in such a case, please connect input capacitors.

<External Output Capacitor>

When applying an external output capacitor, the total output capacitance should be the following maximum value or less.

Maximum Total External Output Capacitance Value: 400 micro F MAX.

If you use output capacitor of exceed 400 micro F, please contact us.



<Caution>

The above capacitance and electrical characteristics are guaranteed under the conditions of measurement via a DC power supply.

When connecting an input inductance or an input power supply that has an output inductance, please confirm the operation including nearby circuitry. Inductance on the input bring about a possibility that the DC-DC Converter may cause unusual oscillation.

Input/Output Capacitor

Input/output capacitor connections; in order to minimize noise, please consider the following items when designing a printed circuit board.

- (1) Be sure to carry out a system characteristic check.
- (2) Use a low impedance capacitor with good high frequency characteristics.
- (3) Shorten the leads of each capacitor as much as possible, and minimize lead inductance.
- (4) On the input and output sides, make the wiring loop between plus and minus as small as possible. This minimizes the influence of any leakage inductance.
- (5) Design the print pattern of the main circuit as thickly and as short as possible.

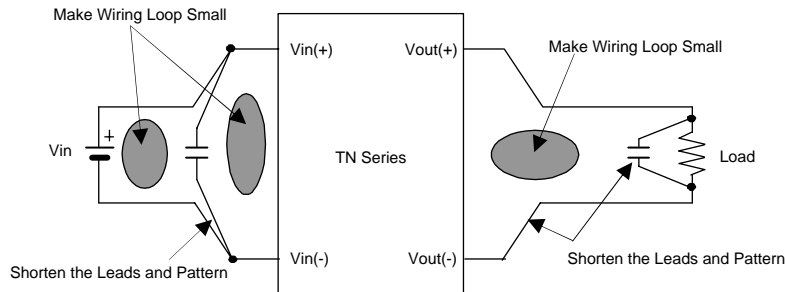

Note • Please read rating and CAUTION (for storage, operating, rating, soldering, mounting and handling) in this catalog to prevent smoking and/or burning, etc.

• This catalog has only typical specifications because there is no space for detailed specifications. Therefore, please approve our product specifications or transact the approval sheet for product specifications before ordering.

13. Caution

13-1 This product should not be operated in parallel or series with other DC-DC Converters.

13-2 Please do not use a connector or a socket for connection to your board of this product.

There is a possibility that it cannot satisfy performance specifications due to the influence of a connector's contact resistance.

13-3 Be sure to provide an appropriate fail-safe function on your product to prevent secondary damage that may be caused by abnormal function or failure of the DC-DC Converter.

13.4 Please connect the input terminals with the correct polarity. If an error in polarity connection is made the DC-DC Converter may be damaged. If the DC-DC Converter is damaged internally, elevated input current may flow, and so the DC-DC Converter may exhibit an abnormal temperature rise, or your product may be damaged. Please add a Diode and Varistor per the following diagram to protect them.

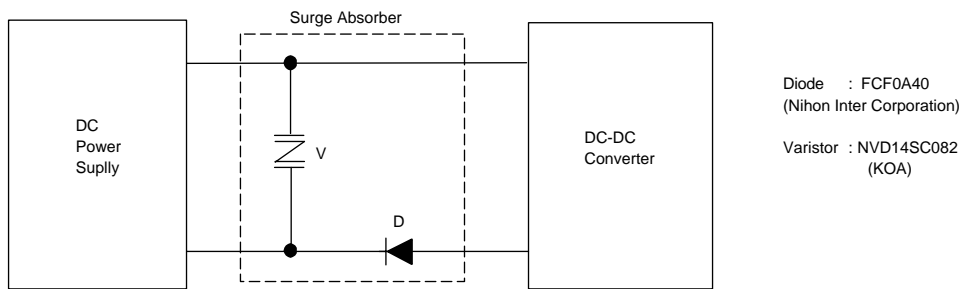

Please select Diode and Varistor after confirming the operation.

⚠ Note

1. Please contact our main sales office or nearby sales office before using our products for the applications listed below which require especially high reliability for the prevention of defects which might directly cause damage to the third party's life, body or property or this products for any other applications that described in the above.

- Aircraft Equipment
- Aerospace Equipment
- Undersea Equipment
- Power Plant Control Equipment
- Medical Equipment
- Transportation Equipment (Vehicles, Trains, Ships, etc.)
- Traffic Signal Equipment
- Disaster Prevention/Crime Prevention Equipment
- Data-processing Equipment

Application of similar complexity and/or reliability requirements to the applications listed in the above.

2. This document was released in January, 2004. The contents, are subject to change without notice. Please confirm specifications when ordering. If there are questions regarding the contents, please ask to our main sales office or nearby sales office.
3. Types and specification in this document are referenced for your information only. Please approve our product specifications or transact the approval sheet for product specifications before ordering.

⚠Note • Please read rating and ⚠CAUTION (for storage, operating, rating, soldering, mounting and handling) in this catalog to prevent smoking and/or burning, etc.
• This catalog has only typical specifications because there is no space for detailed specifications. Therefore, please approve our product specifications or transact the approval sheet for product specifications before ordering.