

DC-DC Converter Application Manual

MPD7D05*S

1. Features

- 1.1 Ultra Low Profile (45.0 by 36.2 by 4.0mm Typ.) SMD.
- 1.2 VE(Value evaluated) model of MPD6D12*S,MPD7D01*S and drop-in to foot pattern of MPD6D12*S,MPD7D01*S
- 1.3 High efficiency & High power density achieved via Murata proprietary synchronous rectifier circuit.
- 1.4 Wide operating temperature range (-40 °C to +85 °C) with power de-rated
- 1.5 Wide input range 36V to 75V
- 1.6 Up to 5 devices in Parallel Operation.
- 1.7 Input to Output isolation: 1.5kV(DC) for one minute.
- 1.8 Built-in Over Current Protection , Over Voltage Protection & Over Heating Protection.
- 1.9 UL60950 Recognized, CE marking(LVD & EMC directive)

2. Product Line Up

2.1 MPD7D05*S Series

Nominal Output Voltage[V]	Part No.
1.2	MPD7D052S
1.5	MPD7D053S
1.8	MPD7D054S
2.5	MPD7D056S
3.3	MPD7D057S
5.0	MPD7D058S

3. Ratings

- 3.1 Operating Temperature Range -40 °C to +85 °C (Please refer the temperature de-rating table.)
- 3.2 Operating Humidity Range 20% to 85%RH (No condensation)
- 3.3 Storage Temperature Range -45 °C. to +90 °C
- 3.4 Storage Humidity Range 10% to 95%RH (No condensation)

4. Electrical Characteristics

4.1 Absolute Maximum Ratings

Items		Unit	Maximum	Remark
Minimum Input Voltage		V	0	
Maximum Input Voltage RC Pin Voltage ALM Pin Voltage	Time	Continuous	V	75
		200μs	V	90
PO Pin Voltage		V	8	
ALM Pin Maximum Sink Current		mA	10	

⚠ Note:

1. This datasheet is downloaded from the website of Murata Manufacturing co., ltd. Therefore, it's specifications are subject to change or our products in it may be discontinued without advance notice. Please check with our sales representatives or product engineers before ordering.
2. This datasheet has only typical specifications because there is no space for detailed specifications. Therefore, please approve our product specifications or transact the approval sheet for product specifications before ordering.

4.2 General Characteristics(Statics , Ambient temperature : Ta=-40 to +85 °C)

Item	Unit	Value	Remark
Rated Input Voltage	V	48	
Input Voltage Range	V	36 to 75	With forced air convection Minimum 100LFM(0.5m/s)
Turn-on Input Voltage	V	32.0 to 36.0	
Hysterisis Voltage	V	Minimum 2	Input voltage difference between turn-on and turn-off
Galvanic Isolation Voltage	Vdc	Minimum 1500	For one minute between input and output
EMC (Radiated EMI / Conduction)		In accordance with CISPR Publication22,Class A (VCCI Class A)	Refer to section 10. Measurement Setup
Safty Standards		UL60950(UL / C-UL)	Recognized
CE Marking		Attached	Self-declaration

⚠ **Note:**

1. This datasheet is downloaded from the website of Murata Manufacturing co., ltd. Therefore, it's specifications are subject to change or our products in it may be discontinued without advance notice. Please check with our sales representatives or product engineers before ordering.
2. This datasheet has only typical specifications because there is no space for detailed specifications. Therefore, please approve our product specifications or transact the approval sheet for product specifications before ordering.

4.3 Output Characteristics Ta = -40 to 85 °C with power de-rated

Items		MPD7D***S						Unit
		052	053	054	056	057	058	
Nominal Output Voltage		1.2	1.5	1.8	2.5	3.3	5.0	V
Output Voltage Regulation Vin =36 to 75V Output current range = 0 to 100%		+5%,-3%						%
Nominal Output Current Maximum is limited with power de-rated		16	17	16	15	15	10	A
Output Current-limit Inception	Min	16.5	17.5	16.5	15.4	15.4	10.3	A
Over Voltage Protection : Note 1	Min	1.44	1.80	2.16	3.00	3.96	6.00	V
Low Voltage Protection :Note 2	Max	1.08	1.35	1.62	2.25	2.97	4.50	V
Efficiency(typ.) Ta=25 °C, Vin = 48V, Nominal output current		86	84	86	89	90	90	%
Output Ripple and Noise	Max	100			Note 3			mVp-p
Output Ripple	Max	50			Note 3			mVp-p

Note 1: Output halted in latch-up mode after mask time 0.5ms(typ.), preventing DC-DC Converter from malfunction by external noise and/or transient output voltage change.

Note 2: Output halted in latch-up mode after mask time 500ms(typ.), preventing DC-DC Converter from malfunction by external noise and/or transient output current change.

Note 3: Refer to section 10. Measurement Setup.

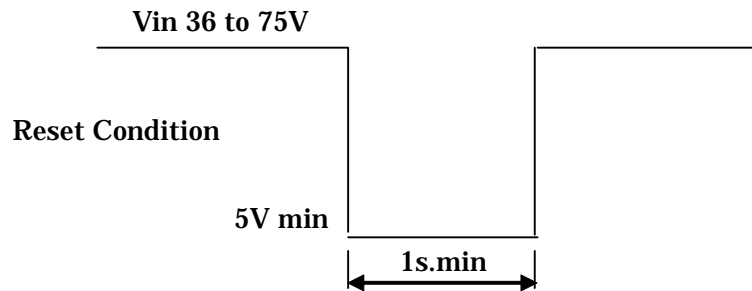
⚠ **Note:**

1. This datasheet is downloaded from the website of Murata Manufacturing co., ltd. Therefore, it's specifications are subject to change or our products in it may be discontinued without advance notice. Please check with our sales representatives or product engineers before ordering.
2. This datasheet has only typical specifications because there is no space for detailed specifications. Therefore, please approve our product specifications or transact the approval sheet for product specifications before ordering.

5 Operation Information

5.1 Reset Condition

In order to reset all functions, the input voltage (V_{in}) must be set under 5V for 1s. min.



5.2 Over Voltage Protection (OVP)

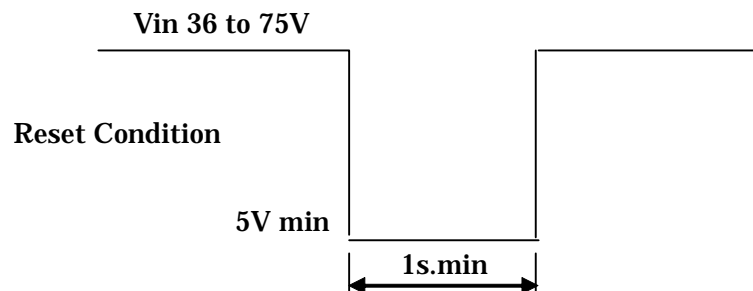
The Isolated DC-DC Converter enters latch-up mode after typical 0.5ms. mask time, when the output voltage is over the value specified in Over Voltage Protection (section 8.1.2) by failure of internal control circuit.

In order to reset, the input voltage must be set under 5V for 1s. min.

Output voltage might exceed the point at which OVP starts to function under conditions of transient input voltage or output current changes.

Therefore, OVP is set to wait for the mask time 0.5ms.

It is recommended to evaluate your appliances installed with the DC-DC Converter.

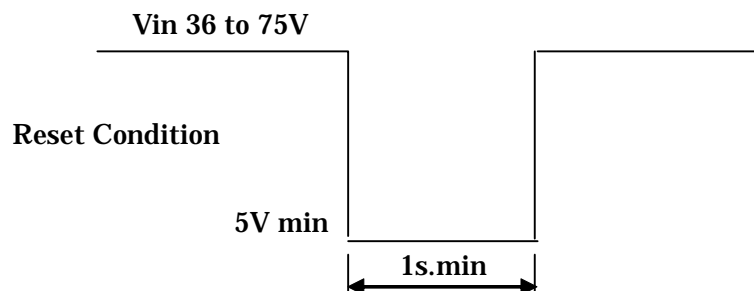


5.3 Low Voltage Protection (LVP)

Over Voltage Protection (OVP)

The Isolated DC-DC Converter enters latch-up mode after typical 500ms. mask time, when the output voltage is under the value specified in Low Voltage Protection (section 8.1.2) by operating Over Current-limit Inception due to failure of internal control or over load.

In order to reset, the input voltage must be set under 5V for 1s. min.



⚠ Note:

1. This datasheet is downloaded from the website of Murata Manufacturing co., ltd. Therefore, it's specifications are subject to change or our products in it may be discontinued without advance notice. Please check with our sales representatives or product engineers before ordering.
2. This datasheet has only typical specifications because there is no space for detailed specifications. Therefore, please approve our product specifications or transact the approval sheet for product specifications before ordering.

5.4 Remote On/Off Control

The connection to a RC pin controls an Isolated DC-DC Converter to turn on/off.

While the Isolated DC-DC Converter is halted via the remote control feature, the alarm function will not operate; refer to Alarm Output (section 5-5).

Start : RC open or connected to -Vin
Halt : RC connected to +Vin

5.5 Alarm Output (ALM)

The Alarm Output can be down to the level of -Vin (Open Drain Output), when Over Voltage Protection or Low Voltage Protection features are activated. The sink current in ALM pin is 10mA max. Multiple Isolated DC-DC Converters running independently and / or in parallel operation can be simultaneously halted by connecting all ALM pins, when the Over Voltage Protection or Low Voltage Protection functions are activated by any single DC-DC Converter. The maximum number connected running DC-DC Converters is 10pcs.

To connect more than 10, please consult Murata.

5.6 Synchronous Turn-on/off

Multiple Isolated DC-DC Converters running independently and / or in parallel operation can be synchronously toggled on & off timing among the running converters, of which the input voltage detection circuits are tied to the detection voltage of a single reference Isolated DC-DC Converter. Every PO pin must be connected for multiple and/or parallel operation.

The Maximum number connected running DC-DC Converters is

: 10pcs for Multiple operation,
: 5pcs for parallel operation of identical output voltage of this TF50A.

It is NOT possible in using other DC-DC Converters with this TF50A for parallel.

To connect more than the above-stated-number, please consult Murata.

6 Parallel Operation

6.1 Parallel Operation Description (Current sharing)

When the output current required is more than that available from one DC-DC Converter an alternative rather than choosing a higher power rated DC-DC Converter is to operate multiple DC-DC Converters in parallel.

It is possible to run up to 5 devices of the same this model in parallel operation.

This series are NOT applicable for parallel operation with other series.

PO pins should be connected so that the turn-on / off of all connected DC-DC Converters are synchronized.

Additionally connecting the ALM pins of the devices in parallel operation enables simultaneous shut down of all DC-DC Converters when one is halted and generates an ALM signal due to an OVP or LVP condition.

6.2 Load Balance in Parallel Operation

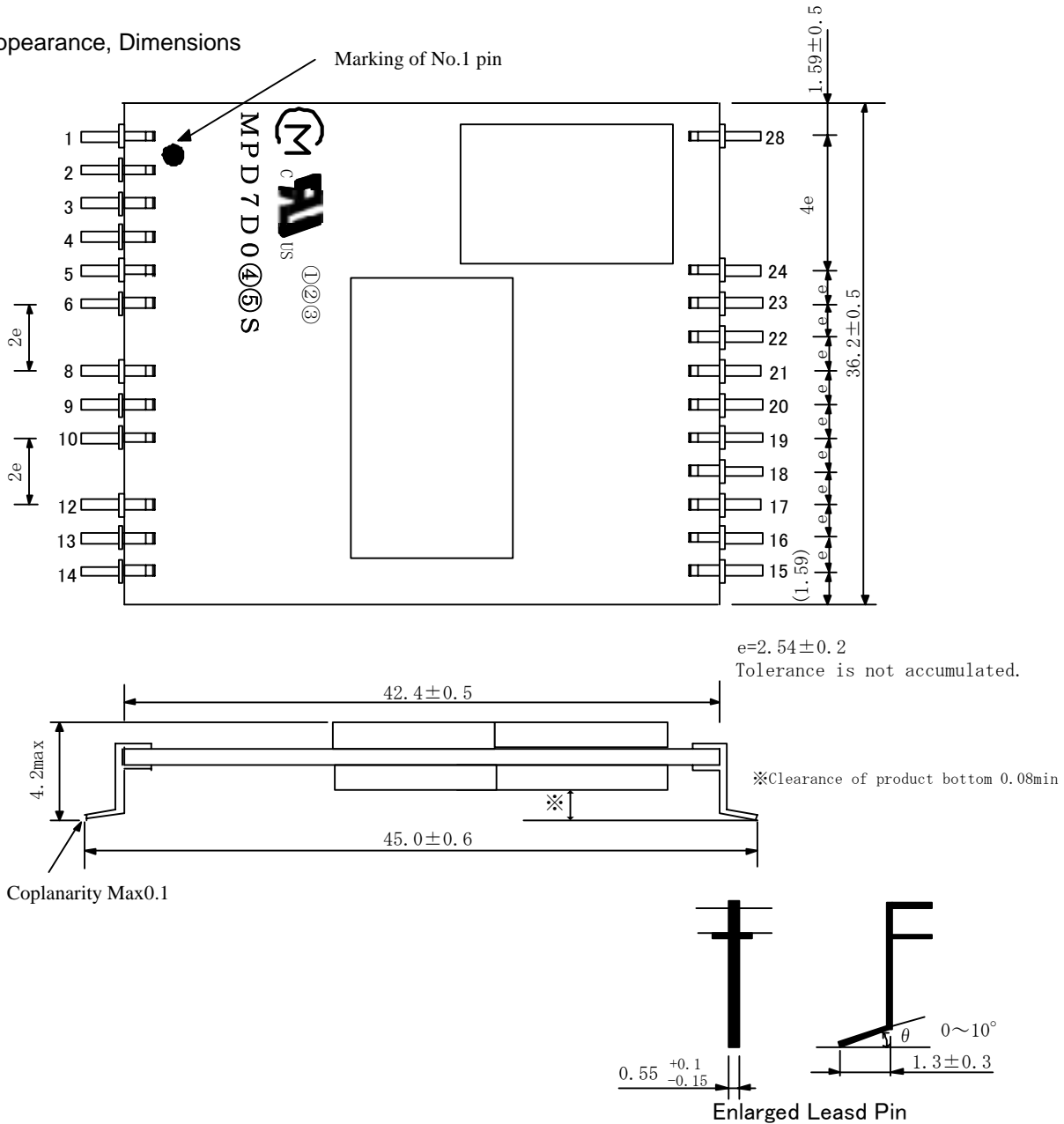
Neither external load balancing circuit nor reverse-current prevention circuit is necessary for Murata's DC-DC converters operating in parallel. Murata's DC-DC converters are designed to regulate load balancing and prevent reverse-current.

The combined devices operated in parallel provide an output voltage within the tolerance specified for either device (e.g. +5% / -3%). This tolerance is maintained throughout the output current variance from zero to the rated current value. This feature automatically balances the output currents from all of the parallel DC-DC converters.

⚠ Note:

1. This datasheet is downloaded from the website of Murata Manufacturing co., ltd. Therefore, it's specifications are subject to change or our products in it may be discontinued without advance notice. Please check with our sales representatives or product engineers before ordering.
2. This datasheet has only typical specifications because there is no space for detailed specifications. Therefore, please approve our product specifications or transact the approval sheet for product specifications before ordering.

7. Appearance, Dimensions



[unit: mm]

Marking
Part Number
Murata CM Mark
Lot Number

MPD7D05*S

- ① Factory symbol
- ② The last number of production year. Example:6 stands for 2006
- ③ Production month. Example:1 stands for January
- 9 stands for September
- O stands for October
- N stands for November
- D stands for December

④⑤ 52,53,54,56,57,58 which is ** of MPD7D0**S

⚠ Note:

1. This datasheet is downloaded from the website of Murata Manufacturing co., ltd. Therefore, it's specifications are subject to change or our products in it may be discontinued without advance notice. Please check with our sales representatives or product engineers before ordering.
2. This datasheet has only typical specifications because there is no space for detailed specifications. Therefore, please approve our product specifications or transact the approval sheet for product specifications before ordering.

Pin Number, Function

Pin No.	Designation	Function	
1,3,5,28	NC	Not Connected	Note1
2	ALM	Alarm	Note2
4	RC	Remote On/Off Control	
6	PO	Parallel Operation	Note3
8,9,10	- Vin	- Input	
12,13,14	+ Vin	+ Input	
15,16,17,18	+V out	+Output	
19,20,21,22,23,24	-V out	-Output	

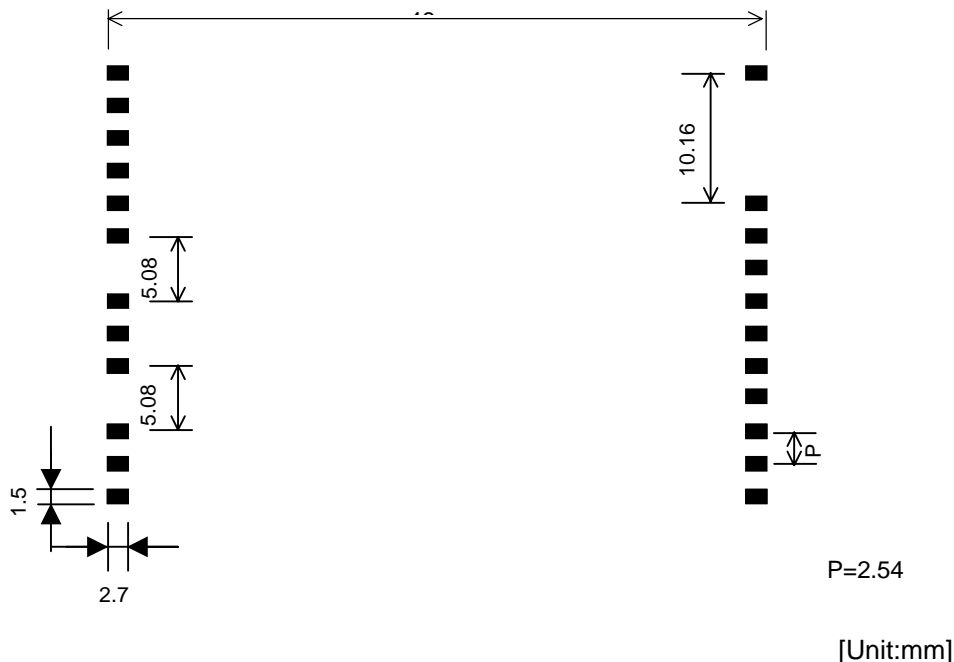
Note 1: It is recommended that the measurement be taken with dipping thermal setting resin at adequate points of bottom of DC-DC Converter, when the devices are mounted on the mother board underside. The dipping points are the surface of a metal core cover and NC pin of number 1,28.

Otherwise the devices may fall from the mother board during the secondary reflow process.

Note 2: Any DC-DC converter halted by abnormal operation forces all DC-DC converters, connected via ALM pins for parallel and/or multiple operation, to discontinue operation.

Note 3: DC-DC converters connected via PO pins can start via synchronized timing for parallel and/or multiple operation.

8. Recommendable Foot Print Pattern

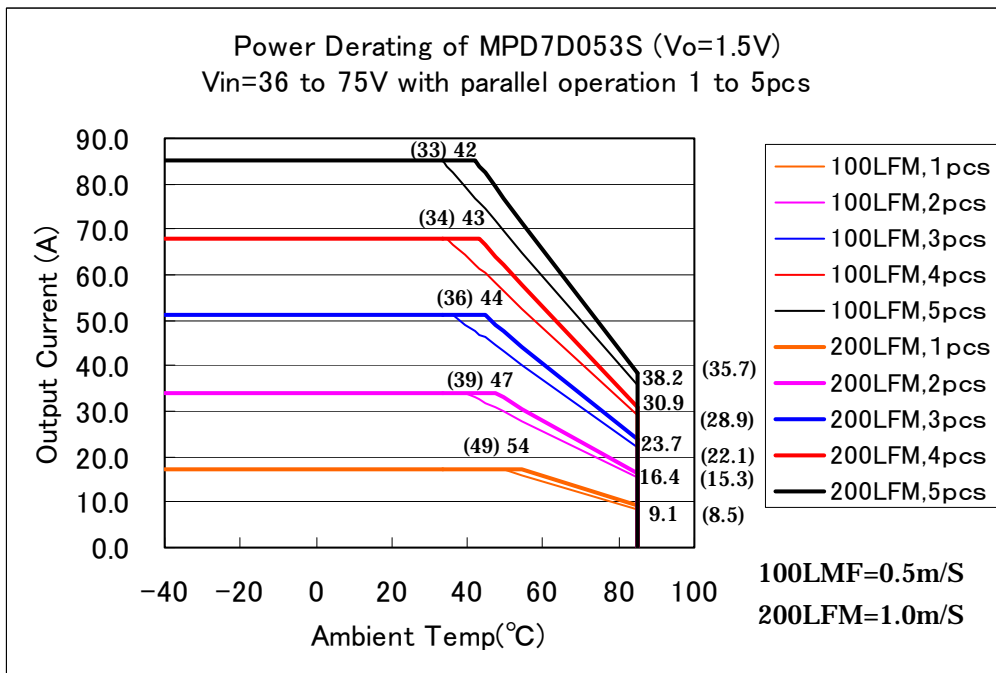
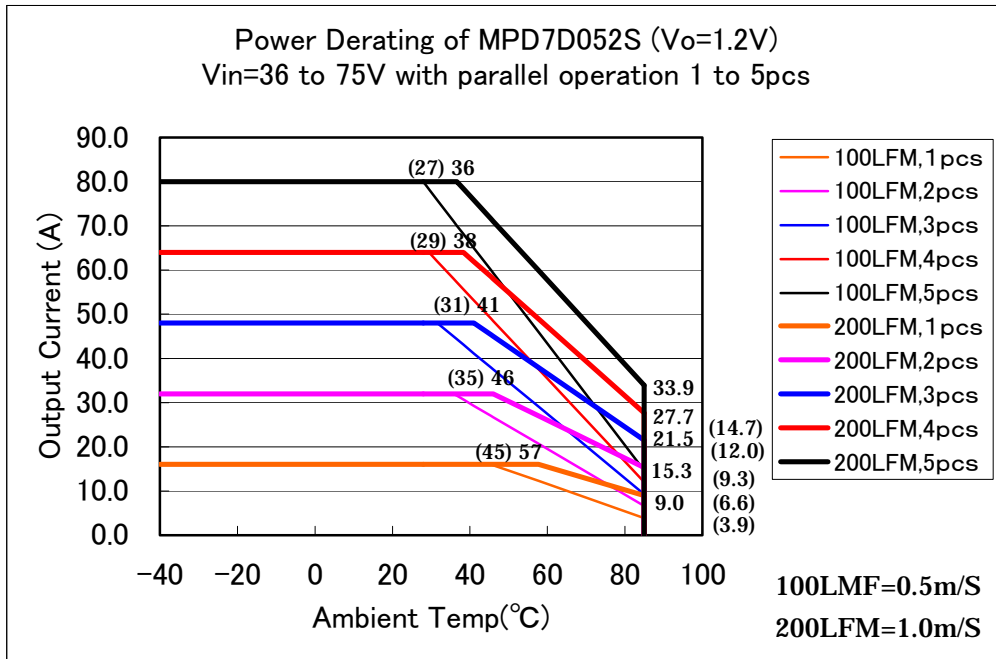


Note : MPD7D05*S series are possible to replace MPD6D12*S or MPD7D01*S without foot print change.

⚠ Note:

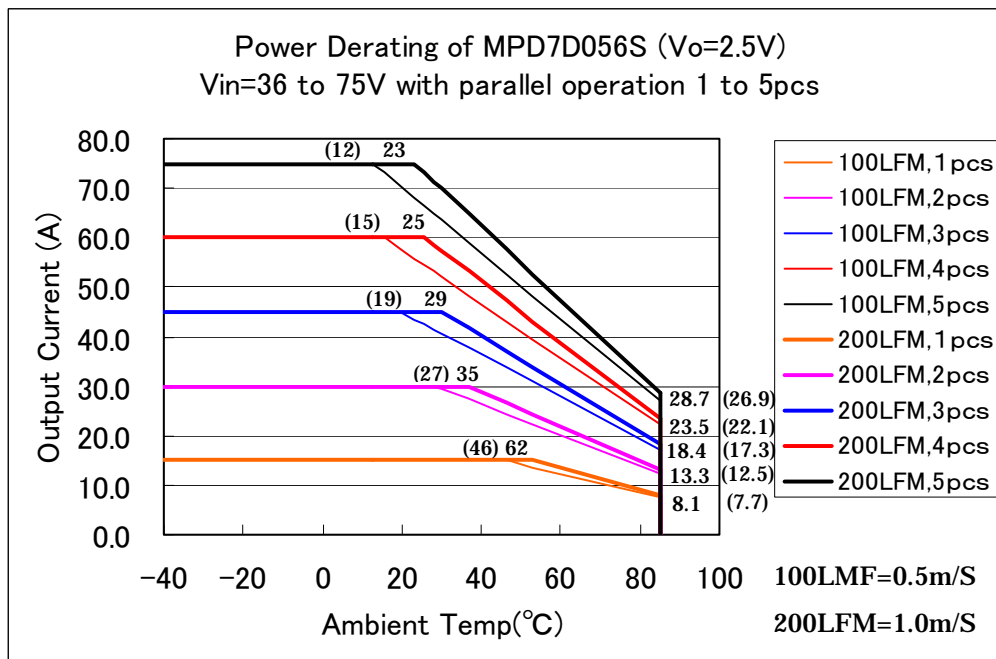
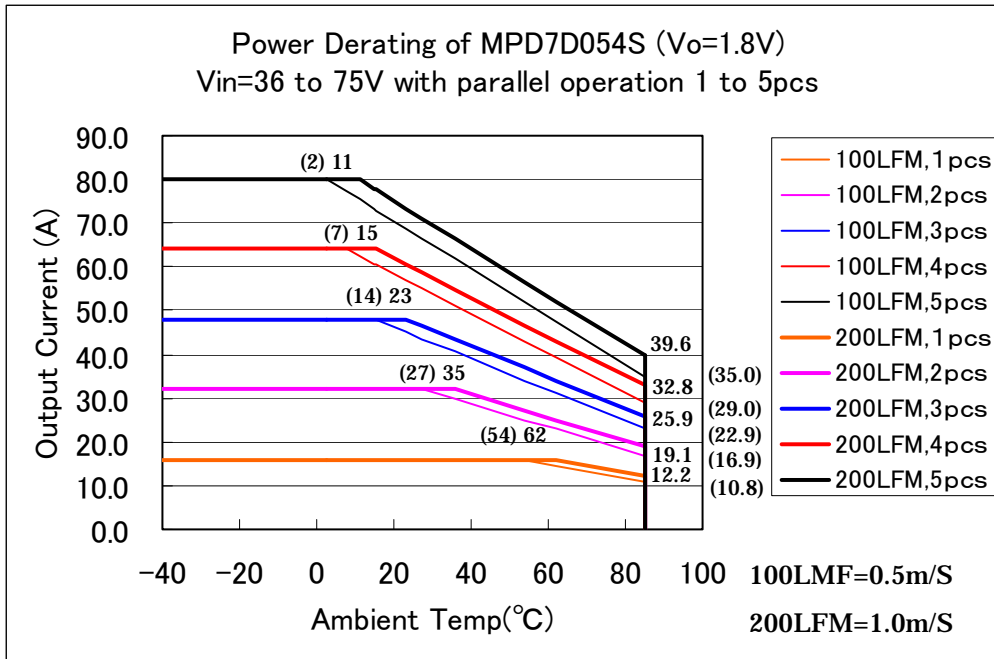
1. This datasheet is downloaded from the website of Murata Manufacturing co., ltd. Therefore, it's specifications are subject to change or our products in it may be discontinued without advance notice. Please check with our sales representatives or product engineers before ordering.
2. This datasheet has only typical specifications because there is no space for detailed specifications. Therefore, please approve our product specifications or transact the approval sheet for product specifications before ordering.

9. Temperature De-rating



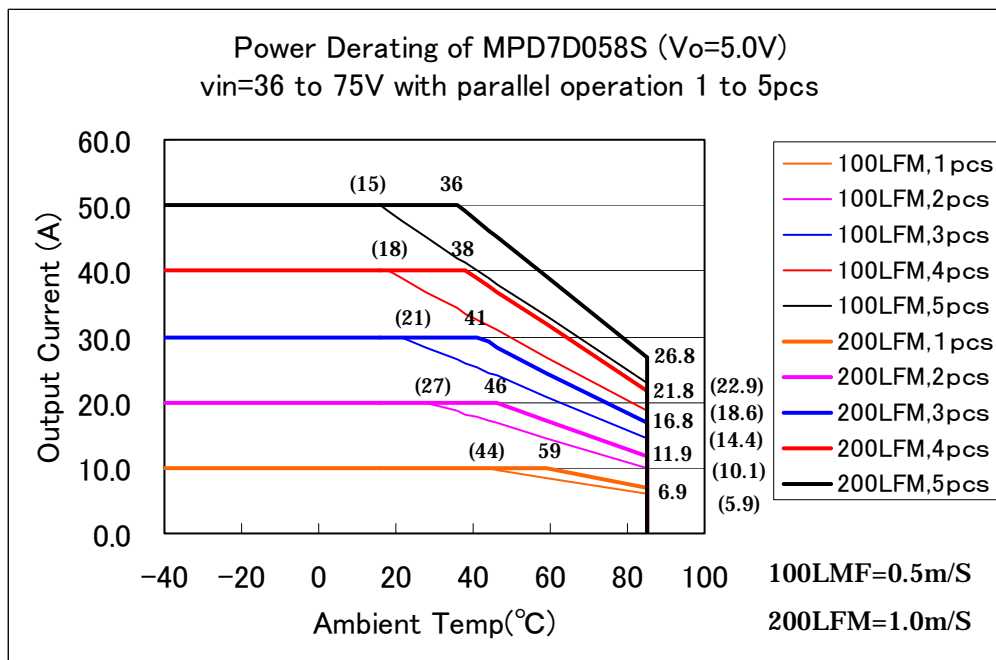
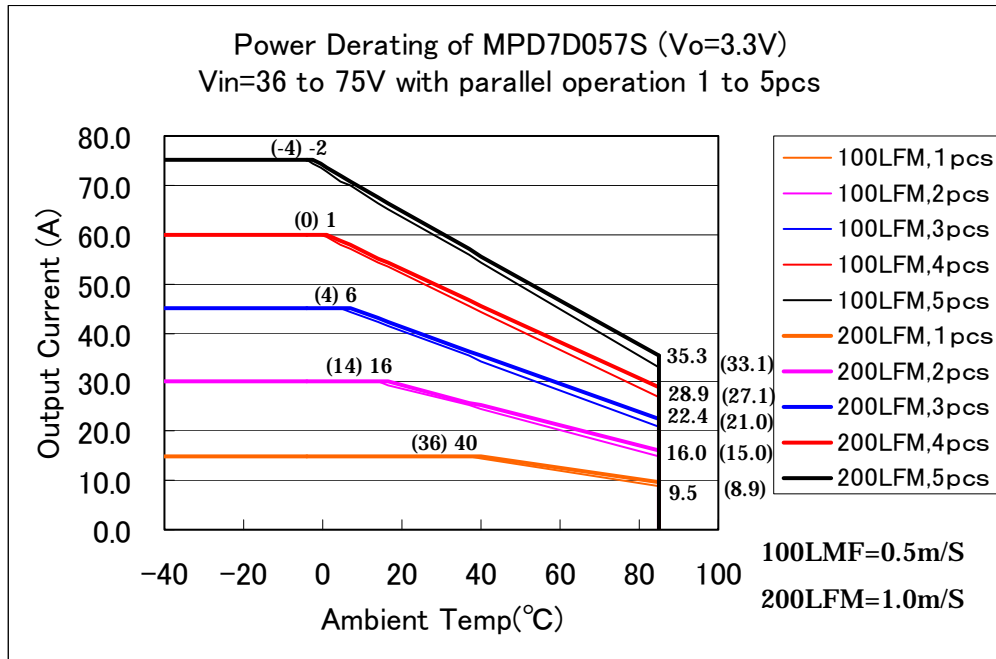
Note:

1. This datasheet is downloaded from the website of Murata Manufacturing co., ltd. Therefore, it's specifications are subject to change or our products in it may be discontinued without advance notice. Please check with our sales representatives or product engineers before ordering.
2. This datasheet has only typical specifications because there is no space for detailed specifications. Therefore, please approve our product specifications or transact the approval sheet for product specifications before ordering.



Note:

1. This datasheet is downloaded from the website of Murata Manufacturing co., ltd. Therefore, it's specifications are subject to change or our products in it may be discontinued without advance notice. Please check with our sales representatives or product engineers before ordering.
2. This datasheet has only typical specifications because there is no space for detailed specifications. Therefore, please approve our product specifications or transact the approval sheet for product specifications before ordering.



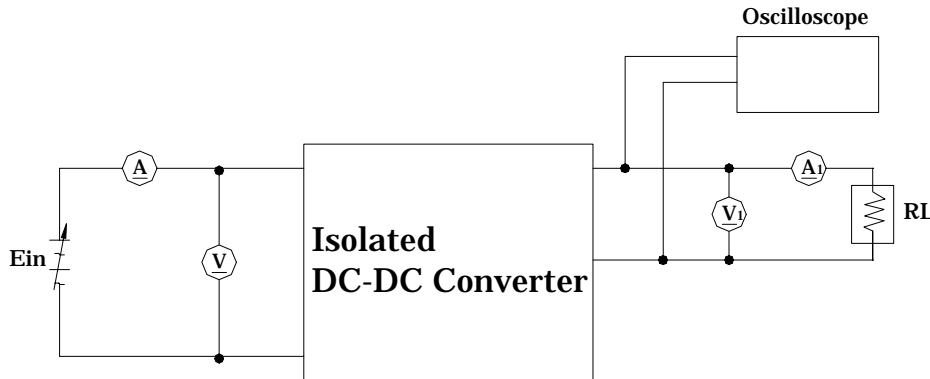
Note:

1. This datasheet is downloaded from the website of Murata Manufacturing co., ltd. Therefore, it's specifications are subject to change or our products in it may be discontinued without advance notice. Please check with our sales representatives or product engineers before ordering.
2. This datasheet has only typical specifications because there is no space for detailed specifications. Therefore, please approve our product specifications or transact the approval sheet for product specifications before ordering.

10. Measurement Setup

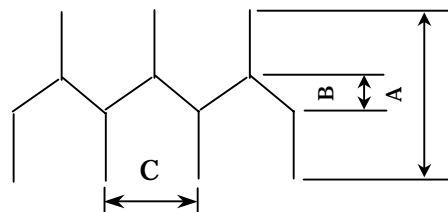
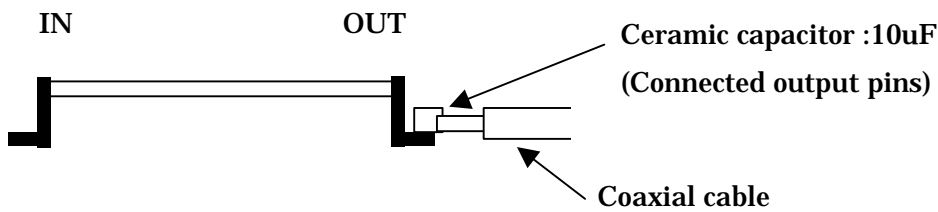
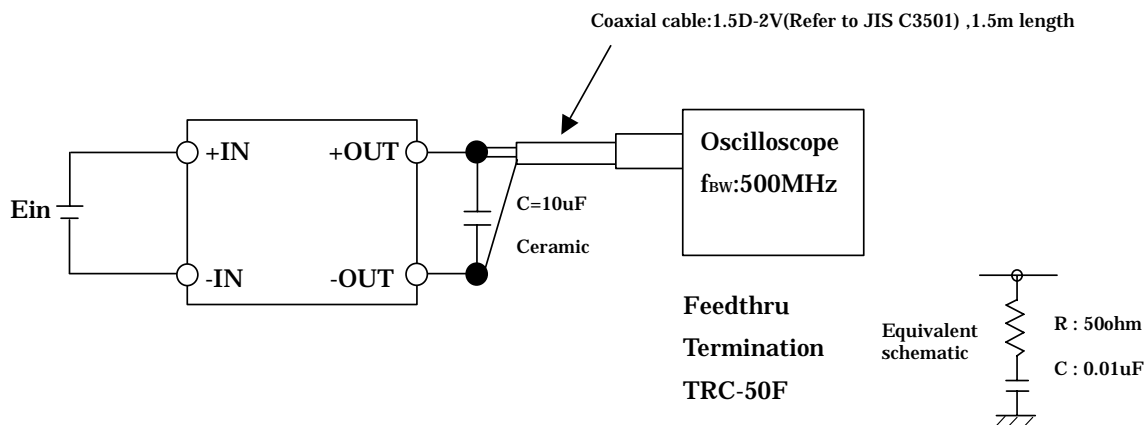
Please follow the below indicated connections when measurements are conducted. Otherwise measured values may deviate from the specifications.

10. 1 General Measurement Circuit



Ein : Stabilized DC Power Supply
(A) (V) : Multimeter
RL : Electronic or Resistive Load

10. 2 Output Ripple & Noise



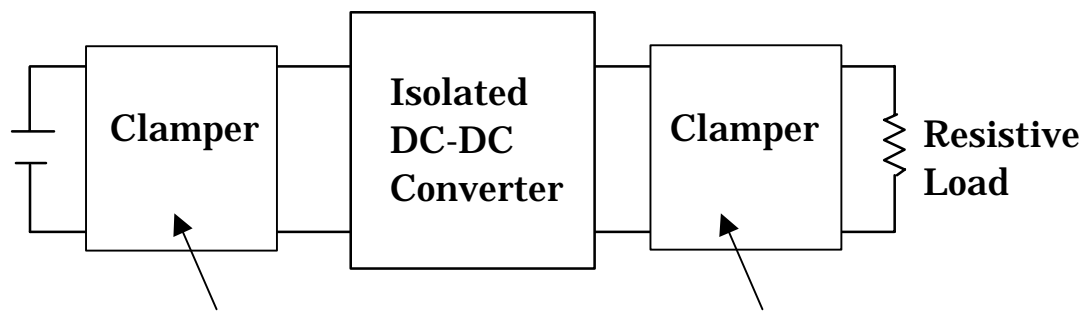
A: Output Ripple & Noise
B: Output Ripple
C: Switching Period

Note:

1. This datasheet is downloaded from the website of Murata Manufacturing co., ltd. Therefore, it's specifications are subject to change or our products in it may be discontinued without advance notice. Please check with our sales representatives or product engineers before ordering.
2. This datasheet has only typical specifications because there is no space for detailed specifications. Therefore, please approve our product specifications or transact the approval sheet for product specifications before ordering.

10. 3 Radiated EMI and Conduction Noise

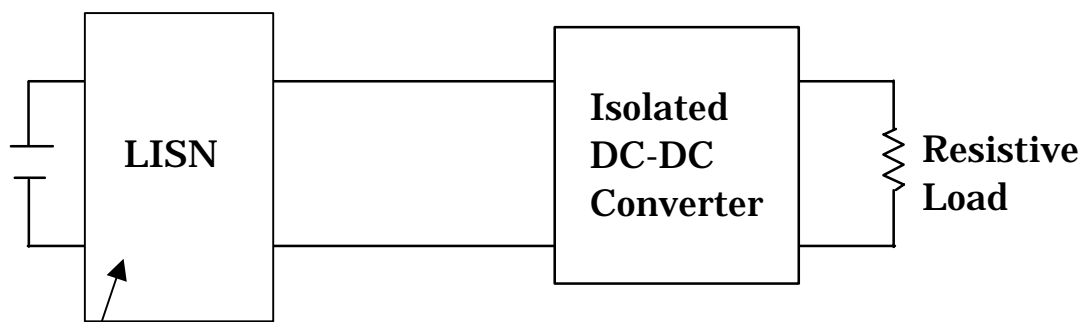
Radiated EMI Measure



ZCAT3035-1330(TDK) by 12pcs

ZCAT3035-1330(TDK) by 5pcs

Conduction Measurement



KNW-407 Kyoritsu Corporation

⚠ Note:

1. This datasheet is downloaded from the website of Murata Manufacturing co., ltd. Therefore, it's specifications are subject to change or our products in it may be discontinued without advance notice. Please check with our sales representatives or product engineers before ordering.
2. This datasheet has only typical specifications because there is no space for detailed specifications. Therefore, please approve our product specifications or transact the approval sheet for product specifications before ordering.

11. Characteristics Data

Fig.11-1~Fig.11-6 expresses the standard characteristic of MPD7D05*S series($T_a=25^\circ\text{C}$)

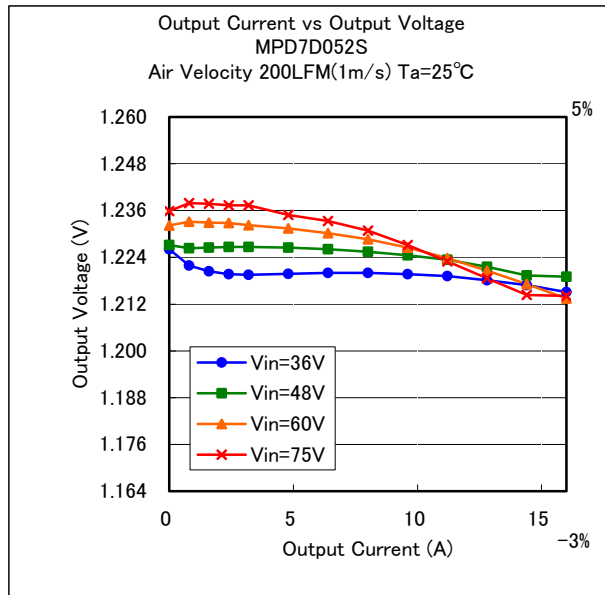
11. 1 MPD7D052S (1.2Vout) Characteristics Data ($T_a = 25^\circ\text{C}$, Cout:None)

Fig.11.1.1 Output Voltage vs Output Current

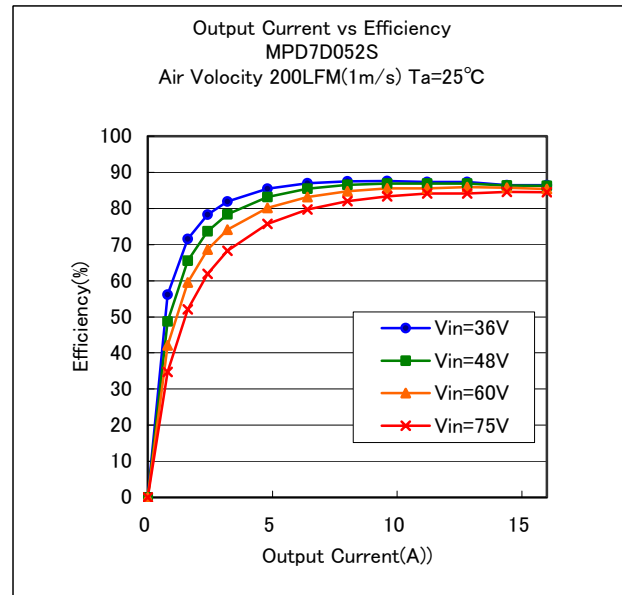


Fig.11.1.2 Efficiency vs Output Current

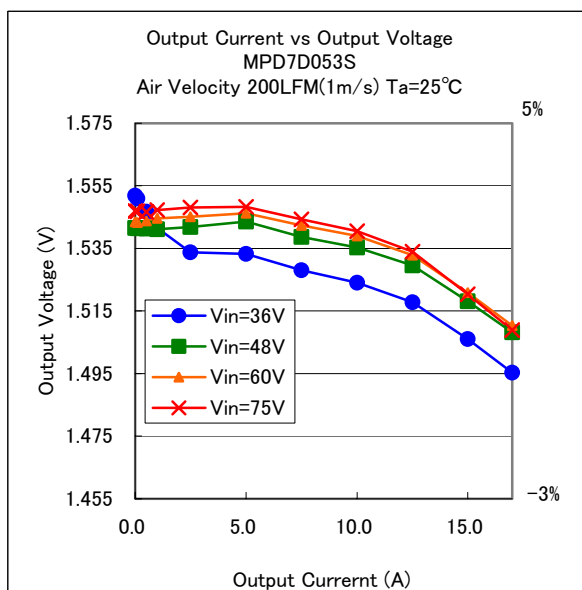
11. 2 MPD7D053S (1.5Vout) Characteristics Data ($T_a = 25^\circ\text{C}$, Cout:None)

Fig.11-2-1. Output Voltage vs Output Current

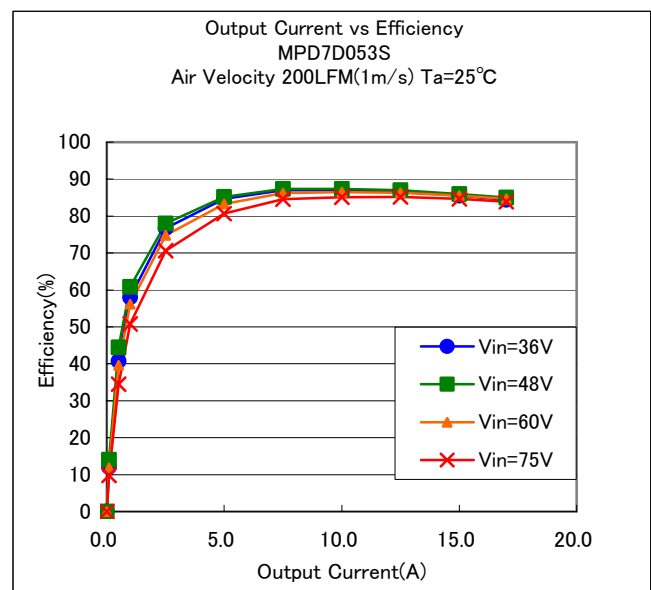


Fig.11-2-2. Efficiency vs Output Current

⚠ Note:

1. This datasheet is downloaded from the website of Murata Manufacturing co., ltd. Therefore, it's specifications are subject to change or our products in it may be discontinued without advance notice. Please check with our sales representatives or product engineers before ordering.
2. This datasheet has only typical specifications because there is no space for detailed specifications. Therefore, please approve our product specifications or transact the approval sheet for product specifications before ordering.

11. 3 MPD7D054S (1.8Vout) Characteristics Data (Ta = 25 °C, Cout:None)

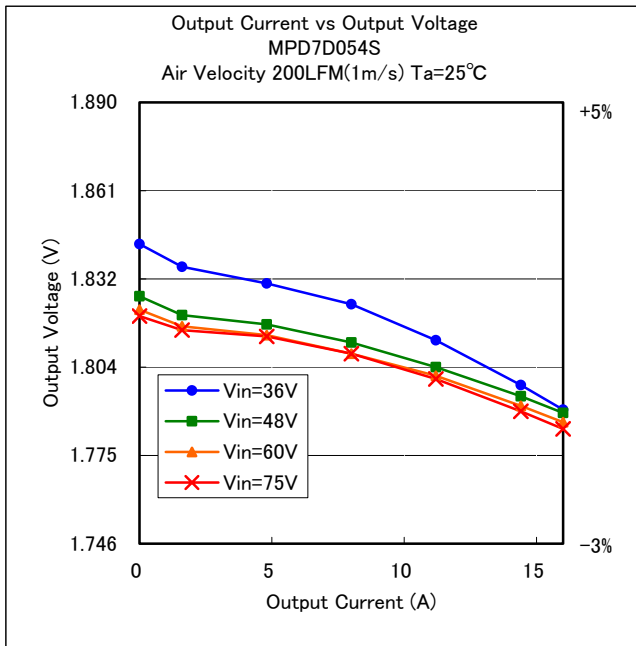


Fig.11-3-1. Output Voltage vs Output Current

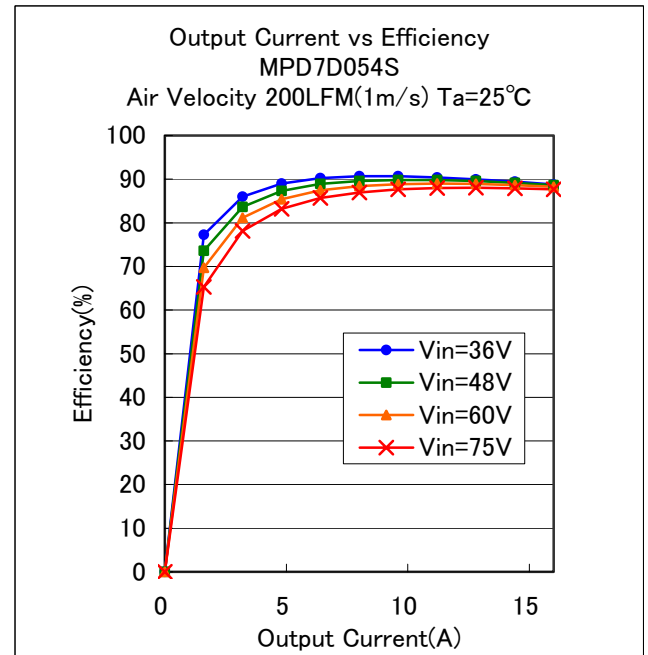


Fig.11-3-2. Efficiency vs Output Current

11. 4 MPD7D056S (2.5Vout) Characteristics Data (Ta = 25 °C, Cout:None)

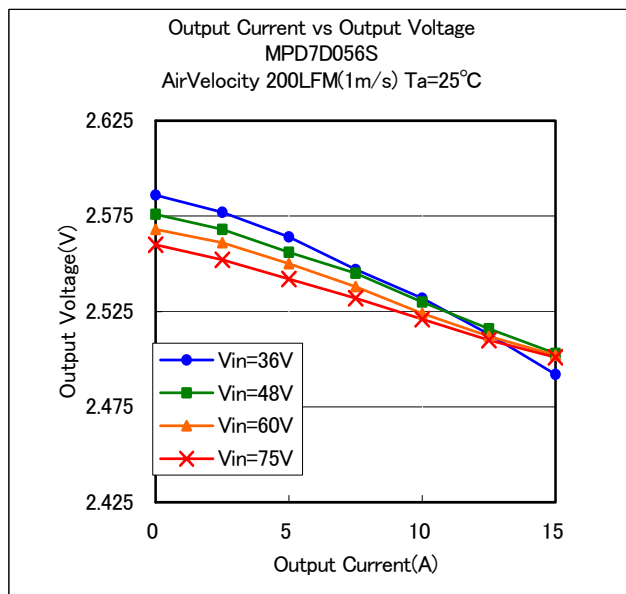


Fig.11-4-1. Output Voltage vs Output Current

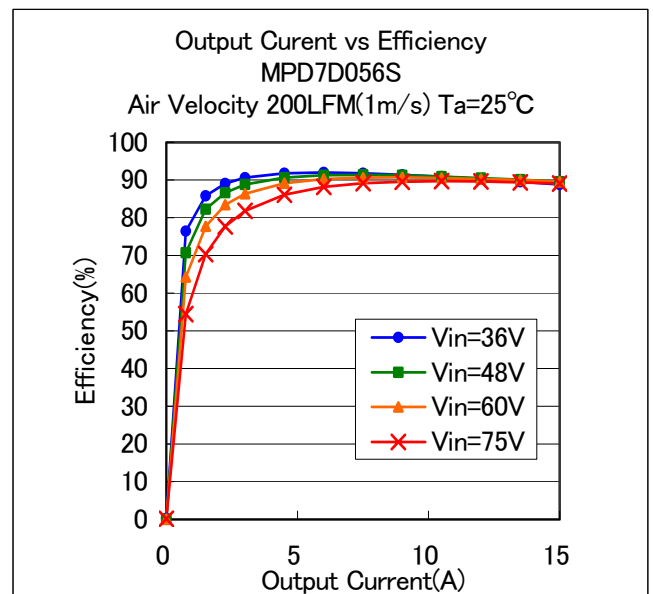


Fig.11-4-2. Efficiency vs Output Current

⚠ Note:

1. This datasheet is downloaded from the website of Murata Manufacturing co., ltd. Therefore, it's specifications are subject to change or our products in it may be discontinued without advance notice. Please check with our sales representatives or product engineers before ordering.
2. This datasheet has only typical specifications because there is no space for detailed specifications. Therefore, please approve our product specifications or transact the approval sheet for product specifications before ordering.

11. 5 MPD7D057S (3.3Vout) Characteristics Data (Ta = 25 °C, Cout:None)

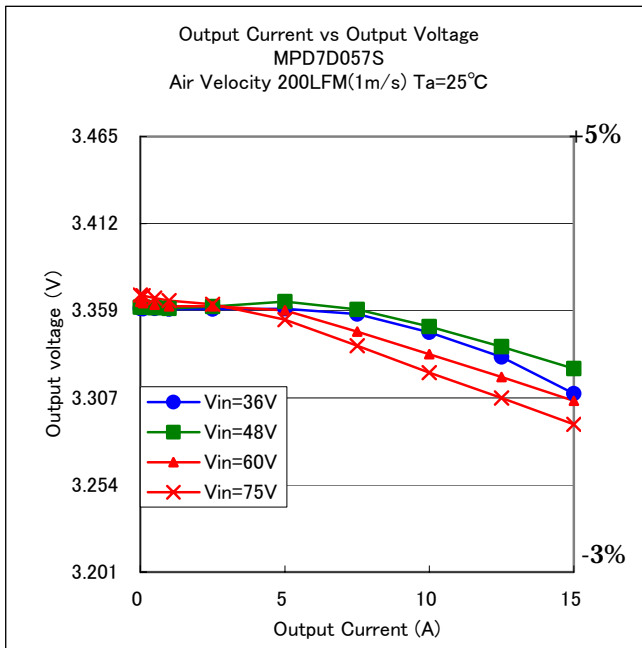


Fig.11-5-1. Output Voltage vs Output Current

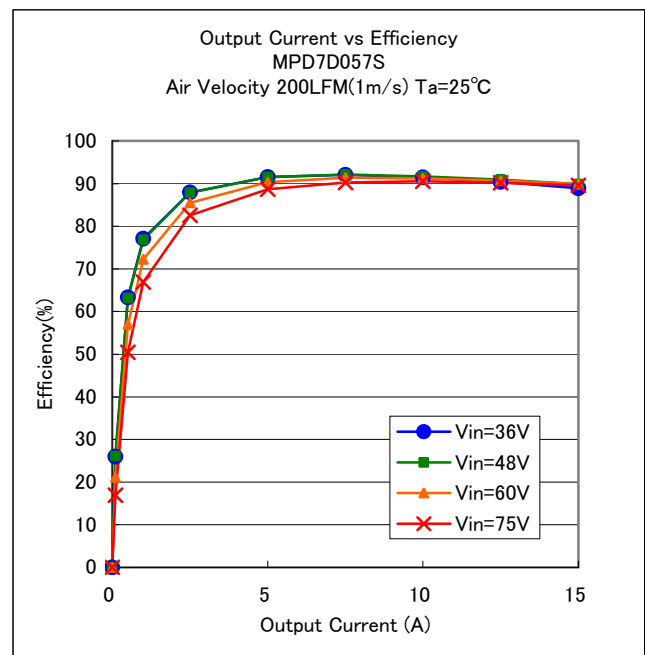


Fig.11-5-2. Efficiency vs Output Current

11. 6 MPD7D058S (5.0Vout) Characteristics Data (Ta = 25 °C, Cout:None)

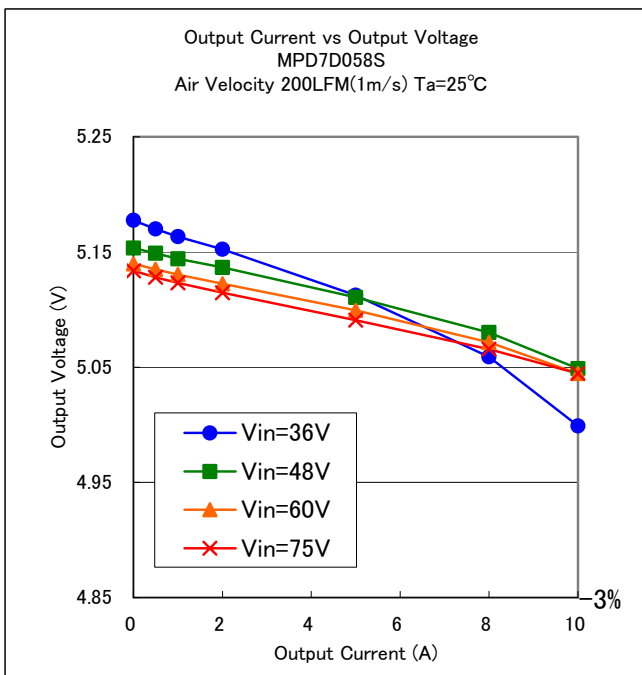


Fig.11-6-1. Output Voltage vs Output Current

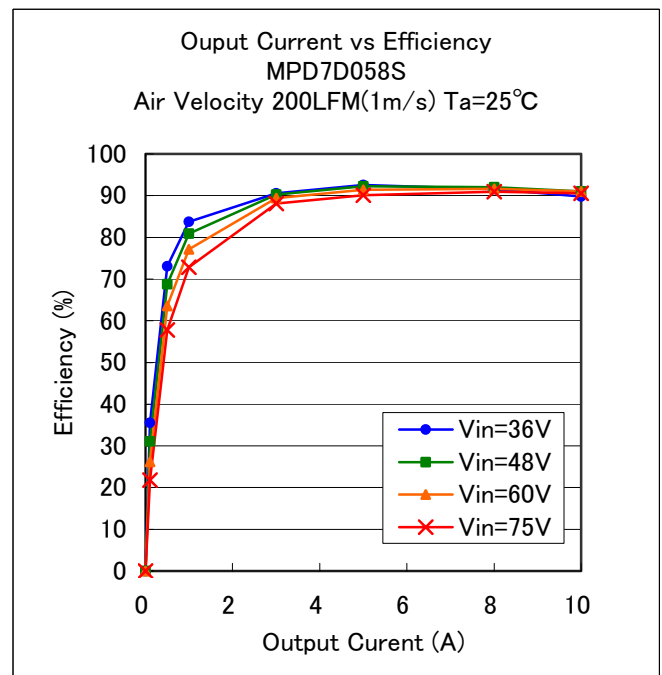


Fig.11-6-2. Efficiency vs Output Current

⚠ Note:

1. This datasheet is downloaded from the website of Murata Manufacturing co., Ltd. Therefore, it's specifications are subject to change or our products in it may be discontinued without advance notice. Please check with our sales representatives or product engineers before ordering.
2. This datasheet has only typical specifications because there is no space for detailed specifications. Therefore, please approve our product specifications or transact the approval sheet for product specifications before ordering.

12. External Input-Output capacitor

<External Input capacitor>

When an inductance or a switch device are connected to the input line, the DC-DC converter is influenced in the load response and may cause unusual oscillations, please connect an external input capacitors in such a case.

<External output capacitor>

When applying an external output capacitor, the total output capacitance should be the following maximum value or less.

Maximum Total External Output Capacitance Value: 400 μ F.

If you use output capacitor of exceed 400 μ F, please contact us.

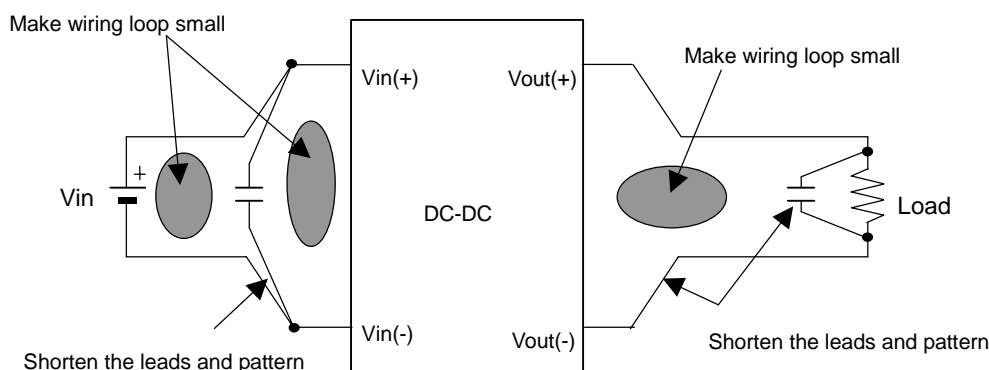
⚠ < Caution >

The above capacitance value is specified under the measurement via a sufficient DC power supply. When connecting an input inductance or an input power supply that has a large output inductance, please confirm the operation including nearby circuitry. The input inductance may cause unusual oscillation of DC-DC Converter.

Input / Output capacitor

Input / output capacitor connections; in order to minimize noise, please consider the following items.

- ① Be sure to carry out a system characteristic check.
- ② Use a low impedance capacitor with good high frequency characteristics.
- ③ Shorten the leads of each capacitor as much as possible to minimize lead inductance.
- ④ Make the area of wiring loop small in the input and output line to minimize leakage inductance.
- ⑤ Shorten the length of PCB pattern and widen patterns for main circuit.

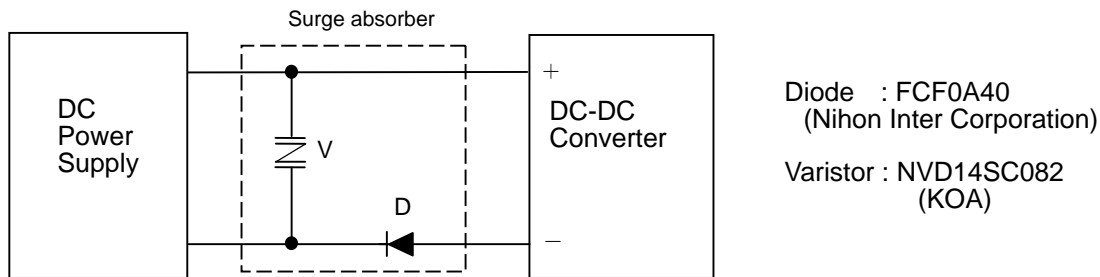


⚠ Note:

1. This datasheet is downloaded from the website of Murata Manufacturing co., ltd. Therefore, it's specifications are subject to change or our products in it may be discontinued without advance notice. Please check with our sales representatives or product engineers before ordering.
2. This datasheet has only typical specifications because there is no space for detailed specifications. Therefore, please approve our product specifications or transact the approval sheet for product specifications before ordering.

13. Caution

13. 1 This product should not be operated in parallel or series with other DC-DC Converters.
13. 2 Please do not use a connector or a socket for connection to your board of this product. Contact resistance may influence the performance of DC-DC Converters.
13. 3 Be sure to provide an appropriate fail-safe function on your product to prevent secondary damage that may be caused by abnormal function or failure of the DC-DC converter.
13. 4 Please connect the input terminals with the correct polarity. If an error in polarity connection is made the DC-DC converter may be damaged. If the the DC-DC converter is damaged internally, elevated input current may flow, and so the DC-DC converter may exhibit an abnormal temperature rise, or your product may be damaged. Please add a Diode and Varistor per the following diagram to protect them.



Please select Diode and Varistor after confirming the operation.

⚠ Notice

1. Please contact our main sales office or nearby sales office before using our products for the applications listed below which require especially high reliability for the prevention of defects which might directly cause damage to the third party's life, body or property or this products for any other applications that described in the above.

Aircraft equipment
Aerospace equipment
Undersea equipment
Power plant control equipment
Medical equipment
Transportation equipment (vehicles, trains, ships, etc.)
Traffic signal equipment
Disaster prevention /crime prevention equipment
Data-processing equipment

Application of similar complexity and/or reliability requirements to the applications listed in the above.

2. This document was released in April 2006. The contents are subject to change without notice. Please confirm specifications when ordering. If there are questions regarding the contents, please ask to our main sales office or nearby sales office.
3. Types and specification in this document are referenced for your information only. Please confirm detailed specifications by approving our individual drawing and specification sheet.

⚠ Note:

1. This datasheet is downloaded from the website of Murata Manufacturing co., ltd. Therefore, it's specifications are subject to change or our products in it may be discontinued without advance notice. Please check with our sales representatives or product engineers before ordering.
2. This datasheet has only typical specifications because there is no space for detailed specifications. Therefore, please approve our product specifications or transact the approval sheet for product specifications before ordering.

4. Wiring of input / output capacitor
In the case of input / output capacitor connection, in order to reduce electrical noise, please design PCBs
5. This product could not be operated parallel or series.
6. Please do not use a connector or a socket for connection with your board of this product.
Electrical performance may be deteriorated the influence of contact resistance.
Please be sure to mount this product with solder.
7. Be sure to provide an appropriate fail-safe function on your product to prevent a second damage that may be caused by the abnormal function or the failure of our product.
8. Please connect the input terminal with proper polarity. If you connect wrong polarity, the DC-DC Converter may be broken. In the case of the DC-DC Converter is damaged, abnormal input current may flow in, and abnormal overheat of the DC-DC Converter, or some damage of your products may occur. Please use a diode and a fuse to as following figure.

**Note**

1. Please contact our main sales office or local sales office before using Murata's products for the applications listed below. These applications are known to require especially high reliability for the prevention of defects which might directly cause damage to a third party's life, body or property.

Note:

1. This datasheet is downloaded from the website of Murata Manufacturing co., ltd. Therefore, it's specifications are subject to change or our products in it may be discontinued without advance notice. Please check with our sales representatives or product engineers before ordering.
2. This datasheet has only typical specifications because there is no space for detailed specifications. Therefore, please approve our product specifications or transact the approval sheet for product specifications before ordering.