

DC-DC Converter Application Manual

MPD7D06*S

1. Features

- Low Profile & Small Size: 39.9 × 30.05 × 8.0mm
- Wide Input Voltage Range(36 to 75V)
- Wide Operating Ambient Temp:-40 to +85 °C.with minimum power de-rating
- Input-Output Isolation Voltage(1.5kVdc)
- UL60950 recognized , Self-declare CE mark

2. Product Line Up

Nominal Output Voltage[V]	Parts No.
3.3	MPD7D067S
5.0	MPD7D068S

3. Ratings

- 3.1 Operating Temperature Range -40 °C ~ +85 °C (Please refer the temperature de-rating.)
- 3.2 Operating Humidity Range 20% ~ 85% (No condensation)
- 3.3 Storage Temperature Range -45 °C ~ +90 °C
- 3.4 Storage Humidity Range 10% ~ 95% (No condensation)

Absolute Rating

Item		Unit	Absolute Rating	Remarks
Minimum Input Voltage		V	0	
Maximum Input Voltage ALM Applied Voltage RC Applied Voltage	Time	Continuous	V	75
		200μs	V	90
PO Applied Voltage		V	8	
Maximum ALM Sink Current		mA	10	

⚠ Note:

1. This datasheet is downloaded from the website of Murata Manufacturing co., ltd. Therefore, it's specifications are subject to change or our products in it may be discontinued without advance notice. Please check with our sales representatives or product engineers before ordering.
2. This datasheet has only typical specifications because there is no space for detailed specifications. Therefore, please approve our product specifications or transact the approval sheet for product specifications before ordering.

5. Electrical Characteristics

5.1 General Characteristics (Static, Ambient temperature : Ta= -40 to +85 °C)

Item	Symbol	Condition	Value			Unit
			Min.	Typ.	Max.	
Input Voltage Range	Vin		36	48	75	V
Turn-on Input Voltage		Vin=increasing	32	-	36	V
Input Voltage difference of Turn-on and Turn-off		PO pin : Open or Connected to PO pin of other DC-DC Converters	2.0	-	-	V
Galvanic Isolation Voltage		Input time : 1 minute	1500	-	-	Vdc

Item	Standard	Note
Noise (Radiation, Conduction)	In accordance with VCCI Class A	Refer to Test Circuit in clause 10
Safety Standard(note 1)	Recognized IEC 60950 UL60950(UL/C-UL), Complied	UL file No.E190503
	CE Marking	CE Mark is shown on a package box.

Note 1: 2A of input current limitation is necessary to apply to the safety standard. It is recommended that a fuse or Current Limitation Circuitry is connected to the input of DC-DC Converter. Individual input of DC-DC Converters should be limited for the application of parallel and/or multiple operation.

⚠ **Note:**

1. This datasheet is downloaded from the website of Murata Manufacturing co., ltd. Therefore, it's specifications are subject to change or our products in it may be discontinued without advance notice. Please check with our sales representatives or product engineers before ordering.
2. This datasheet has only typical specifications because there is no space for detailed specifications. Therefore, please approve our product specifications or transact the approval sheet for product specifications before ordering.

5.2 Specific Characteristics (Ta= -40 to +85°C with power de-rated.)

Part Number		MPD7D067S				
Item	Symbol	Condition	Value			Unit
			Min.	Typ.	Max.	
Nominal Output Voltage	Vo		-	3.3	-	V
Output Voltage Variation	Δregtot	Vin=36 to 75V, Io=0 to 10.6A Ta=-40 to +85°C	-3		+5	%
Output Current	Io	Power de-rated.	0	-	10.6	A
Efficiency	η	at rated Vin, Io, Ta=25°C	-	91	-	%
Ripple Voltage	Vr	Refer to Test Circuit	-	-	50	mVpp
Ripple Voltage & Noise			-	-	100	
Over Current Protection	Iocp		10.9	-	-	A
Over Voltage Protection	Vovp	Output halts in latch-up mode after mask time 0.5msec (typ) to avoid malfunction by noise and transient change. Input turn off and on to reset.	3.96	-	-	V
Low Voltage Protection	Vlvp	Output halts in latch-up mode after mask time 500msec (typ) to avoid malfunction by noise and transient change. Input turn off and on to reset.	-	-	2.97	V

Part Number		MPD7D068S				
Item	Symbol	Condition	Value			Unit
			Min.	Typ.	Max.	
Nominal Output Voltage	Vo		-	5	-	V
Output Voltage Variation	Δregtot	Vin=36 to 75V, Io=0 to 7A Ta=-40 to +85°C	-3		+5	%
Output Current	Io	Power de-rated.	0	-	7	A
Efficiency	η	at rated Vin, Io, Ta=25°C	-	92	-	%
Ripple Voltage	Vr	Refer to Test Circuit	-	-	50	mVpp
Ripple Voltage & Noise			-	-	100	
Over Current Protection	Iocp		7.2	-	-	A
Over Voltage Protection	Vovp	Output halts in latch-up mode after mask time 0.5msec (typ) to avoid malfunction by noise and transient change. Input turn off and on to reset.	6	-	-	V
Low Voltage Protection	Vlvp	Output halts in latch-up mode after mask time 500msec (typ) to avoid malfunction by noise and transient change. Input turn off and on to reset.	-	-	4.5	V

 **Caution**

The above electrical characteristics are guaranteed in the condition that the impedance of the input power supply is sufficiently low as shown in clause 10.

Connecting an input inductance or using an input power supply with output inductance may cause an unstable operation of this product. Please check the proper operation of this product with the peripheral circuits on your product.

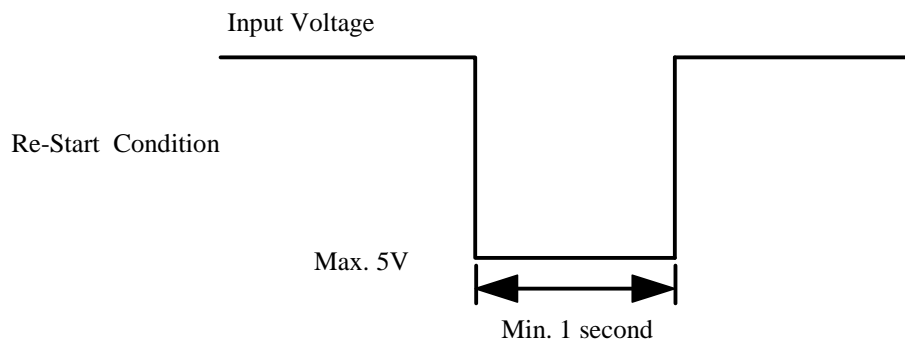
 **Note:**

1. This datasheet is downloaded from the website of Murata Manufacturing co., Ltd. Therefore, it's specifications are subject to change or our products in it may be discontinued without advance notice. Please check with our sales representatives or product engineers before ordering.
2. This datasheet has only typical specifications because there is no space for detailed specifications. Therefore, please approve our product specifications or transact the approval sheet for product specifications before ordering.

5.3. Low Voltage Protection

Output halts in latch-up mode after 500msec(typ) mask time while output voltage is below the value of low voltage protection specified in 9.1.clause with failure of controller circuit or over load condition.

Output will re-start after input turns off for Min.1 second with input voltage less than 5V.



5.4. Remote On/Off Control

Start and halt is possible with a control signal.

While the control signal stops output from DC-DC converter, alarm output does not send any signal.

Start : RC is open or connected to-Vin.

Halt : RC is connected to +Vin.

5.5. Alarm Output

ALM pin is down to the same voltage level of-Vin pin and sends an alarm signal. (open-drain output)

Sink current in ALM pin is Max.10mA.

It is possible to halt all of the connected DC-DC converters when any one is halted with over voltage protection or low voltage protection, with connecting all ALM pins for the application of parallel/multiple operation (Note 1) with plural DC-DC converters.

The maximum number connecting DC-DC converters is 5pcs of parallel operation, 10pcs of multiple operation, for the purpose of halting all DC-DC converters connected with ALM pin each other.

Please contact us when more than these figures.

Note 2 The parallel operation of this series is limited to only the same model.

5.6. Synchronous Turn-on/off

It is possible to avoid the unevenness of turn-on timing with unifying the various Turn-on input voltage to a certain voltage which one DC-DC converter has, and with connecting PO pins each other for the application of parallel/multiple operation (Note 2) of plural DC-DC converters.

It is necessary to connect PO pins for parallel operation.

The maximum number connecting DC-DC converters is 5pcs of parallel operation, 10pcs of multiple operation, for the purpose of synchronous turn-on/off with connecting PO pins.

Please contact us when more than these figures.

Note 2 The parallel operation of this series is limited to only the same model.

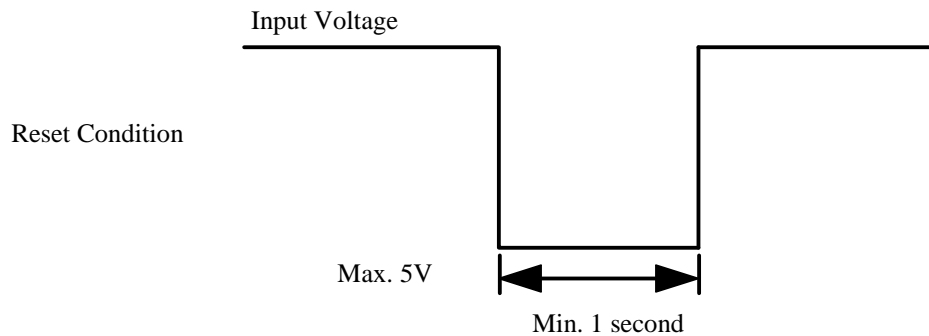
⚠ Note:

1. This datasheet is downloaded from the website of Murata Manufacturing co., ltd. Therefore, it's specifications are subject to change or our products in it may be discontinued without advance notice. Please check with our sales representatives or product engineers before ordering.
2. This datasheet has only typical specifications because there is no space for detailed specifications. Therefore, please approve our product specifications or transact the approval sheet for product specifications before ordering.

6. Operation information

6.1. Reset Condition

In order to reset all function, the input Voltage is set under 5V for Min.1 second.



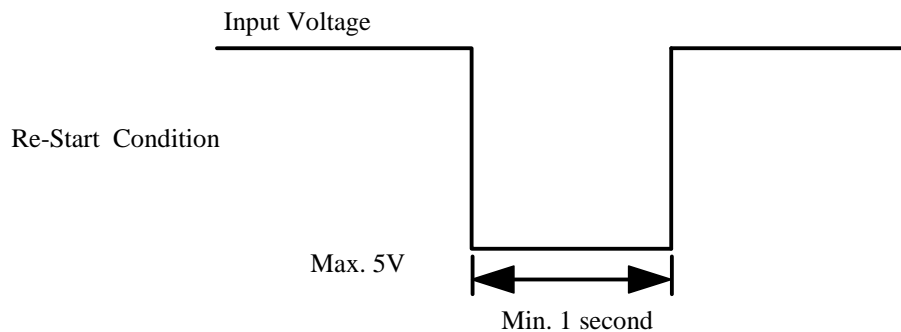
6.2. Over Voltage Protection

Output halts in latch-up mode after 0.5msec(typ) mask time while Output Voltage is over the value of over voltage protection specified in 9.1. clause with failure of controller circuit.

Output will re-start after input turns off for Min. 1 second with input voltage less than 5V.

Output voltage might exceed the point at over voltage protection under the specific condition of transient change of input voltage or output load, in this condition over voltage protection wait its start until the mask time.

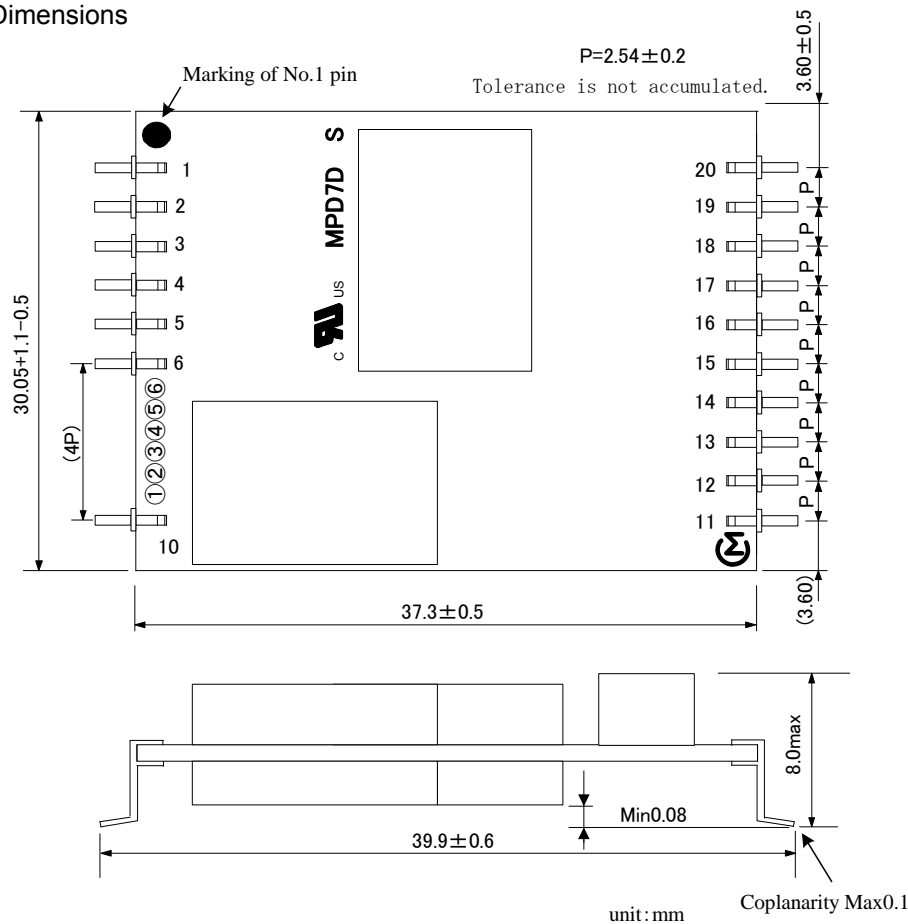
It is recommended to evaluate your appliance installed with DC-DC converter.






⚠ Note:

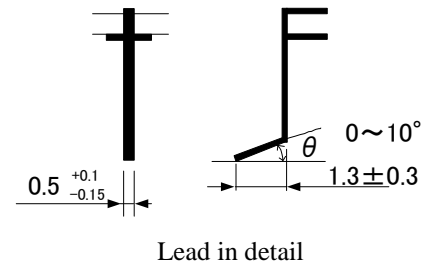
1. This datasheet is downloaded from the website of Murata Manufacturing co., ltd. Therefore, it's specifications are subject to change or our products in it may be discontinued without advance notice. Please check with our sales representatives or product engineers before ordering.
2. This datasheet has only typical specifications because there is no space for detailed specifications. Therefore, please approve our product specifications or transact the approval sheet for product specifications before ordering.

7. Appearance, Dimensions



Marking

- (1) MFG ID 
- (2) Lot No. 
- ① Production factory Mark
- ② Production Year
- ③ Production Month (1,2,3,...9,O,N,D)
- (3) Product Number  :
Part number of underlined MPD6D06*S



8. Pin Number and Function

Pin No.	Symbol	Function
1,10,11,15,20	NC	
2	+Vout	(+) Output
3	+Vout	(+) Output
4	+Vout	(+) Output
5	-Vout	(-) Output
6	-Vout	(-) Output
12	ALM	Alarm output to stop all in abnormality.
13	RC	Remote On/Off
14	PO	Parallel Operation
16	+Vin	(+) Input
17	+Vin	(+) Input
18	-Vin	(-) Input
19	-Vin	(-) Input

⚠ Note:

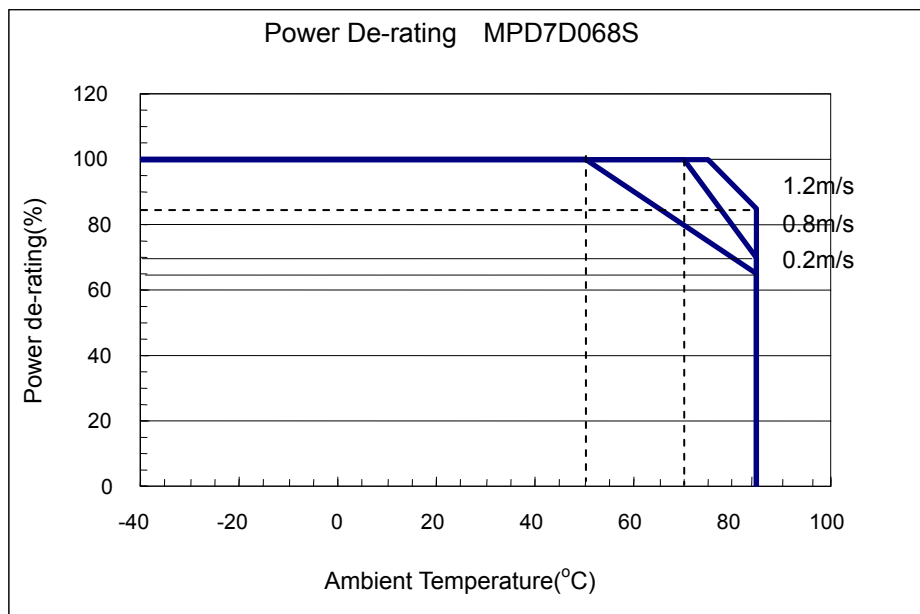
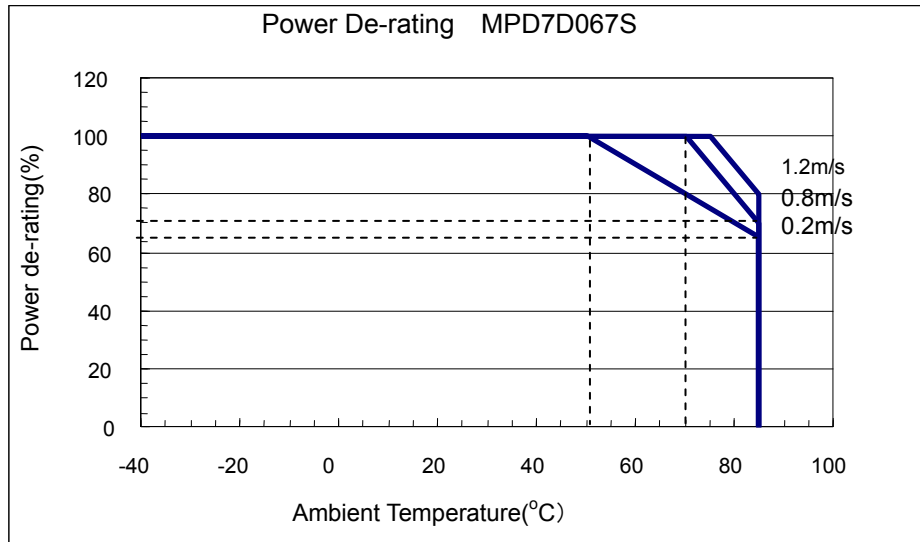
- This datasheet is downloaded from the website of Murata Manufacturing co., Ltd. Therefore, it's specifications are subject to change or our products in it may be discontinued without advance notice. Please check with our sales representatives or product engineers before ordering.
- This datasheet has only typical specifications because there is no space for detailed specifications. Therefore, please approve our product specifications or transact the approval sheet for product specifications before ordering.

9. Power De-rating MPD7D06*S <For Reference Only>

【1pcs operation use】

<Notice>

We would like to emphasize that these data are based on our experimental measurement.
For parallel operation, Please equalize line impedance from each of DC-DC Converters.



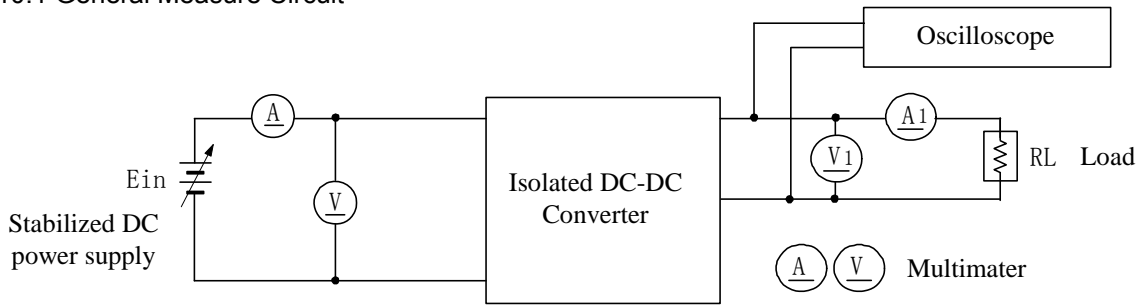
⚠ Note:

1. This datasheet is downloaded from the website of Murata Manufacturing co., Ltd. Therefore, it's specifications are subject to change or our products in it may be discontinued without advance notice. Please check with our sales representatives or product engineers before ordering.
2. This datasheet has only typical specifications because there is no space for detailed specifications. Therefore, please approve our product specifications or transact the approval sheet for product specifications before ordering.

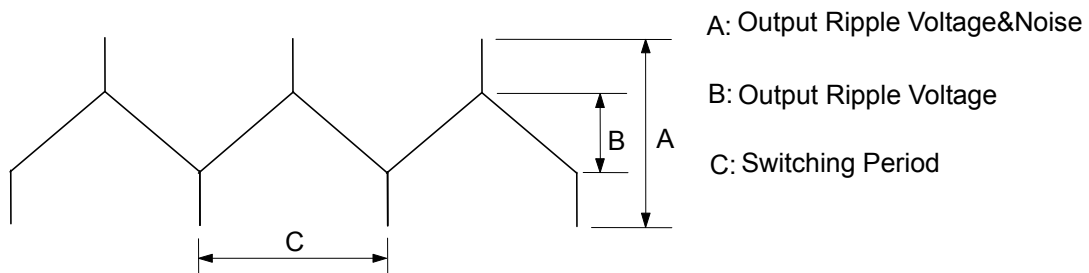
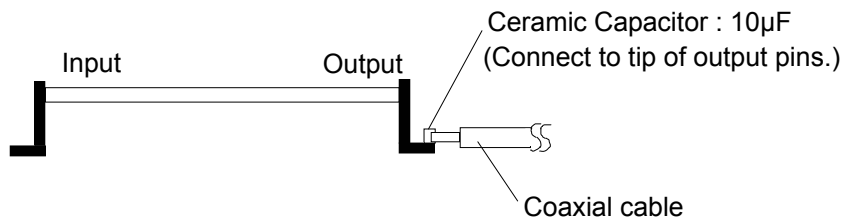
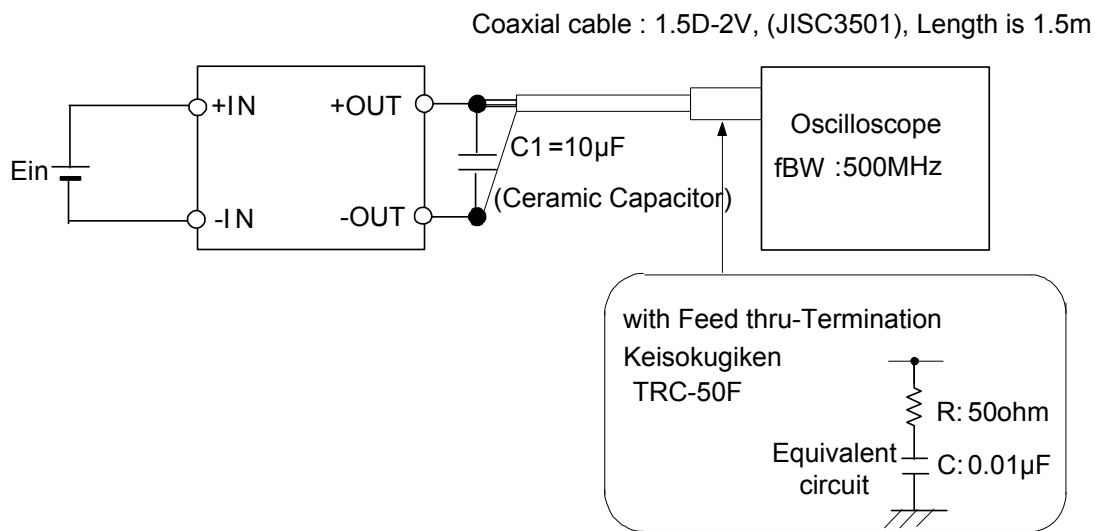
10. Test Circuit

In the following test circuit, the measured values should meet those of clause 9.

10.1 General Measure Circuit



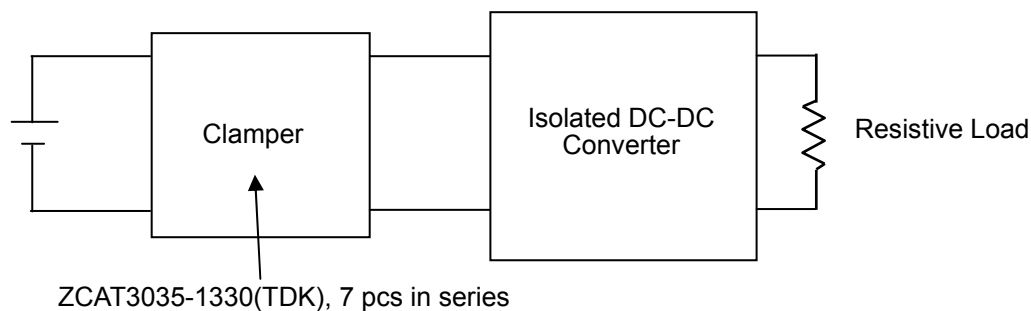
10.2 Output Ripple & Noise



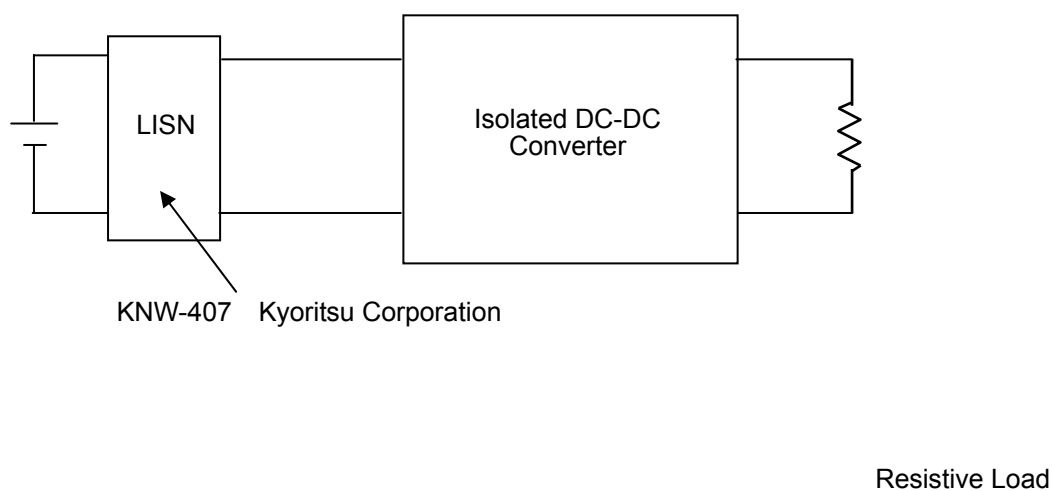
⚠ **Note:**

1. This datasheet is downloaded from the website of Murata Manufacturing co., ltd. Therefore, it's specifications are subject to change or our products in it may be discontinued without advance notice. Please check with our sales representatives or product engineers before ordering.
2. This datasheet has only typical specifications because there is no space for detailed specifications. Therefore, please approve our product specifications or transact the approval sheet for product specifications before ordering.

10.3 Radiation Noise



10.4 Conduction Noise



Measurement at Radiation Noise, Conductive Noise, Output ripple & Noise.

Please measure Radiation Noise, Conductive Noise and Output ripple & Noise with conforming to the Test Circuit in clause 10

Otherwise the noise might not meet the specified values.

⚠ **Note:**

1. This datasheet is downloaded from the website of Murata Manufacturing co., ltd. Therefore, it's specifications are subject to change or our products in it may be discontinued without advance notice. Please check with our sales representatives or product engineers before ordering.
2. This datasheet has only typical specifications because there is no space for detailed specifications. Therefore, please approve our product specifications or transact the approval sheet for product specifications before ordering.

11. Characteristics Data

Fig.11-1 ~ Fig.11-2 expresses the standard characteristic of MPD7D06*S series ($T_a=25\text{ }^\circ\text{C}$)

11. 1 MPD7D067S (3.3Vout) Characteristics Data ($T_a = 25\text{ }^\circ\text{C}$, Cout:None)

Fig.11-1-1 Output Current vs Output Voltage

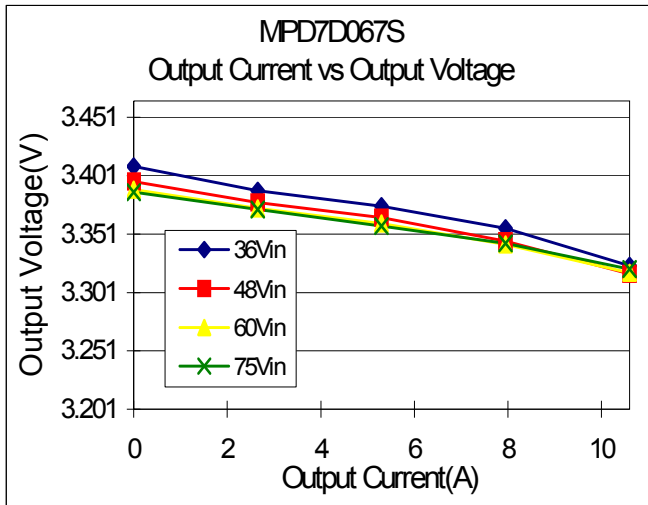


Fig.11-1-2 Output Current vs Efficiency

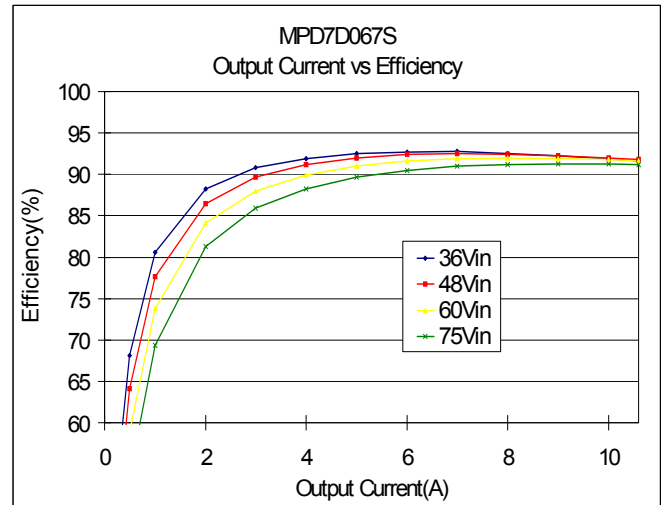
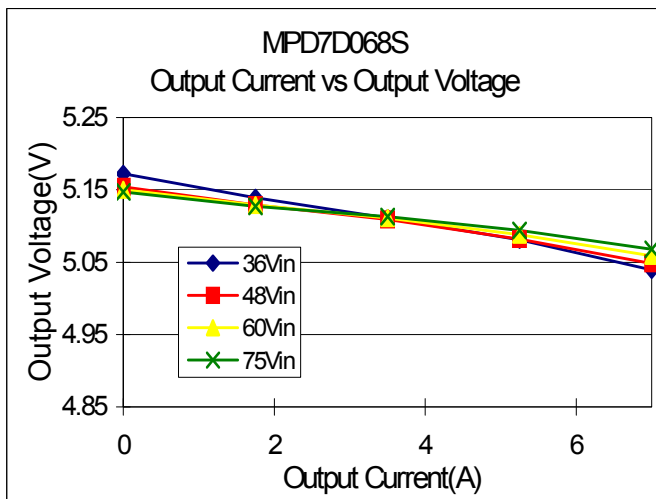
11. 2 MPD7D068S (5.0Vout) Characteristics Data ($T_a = 25\text{ }^\circ\text{C}$, Cout:None)

Fig.12-1-1 Output Current vs Output Voltage

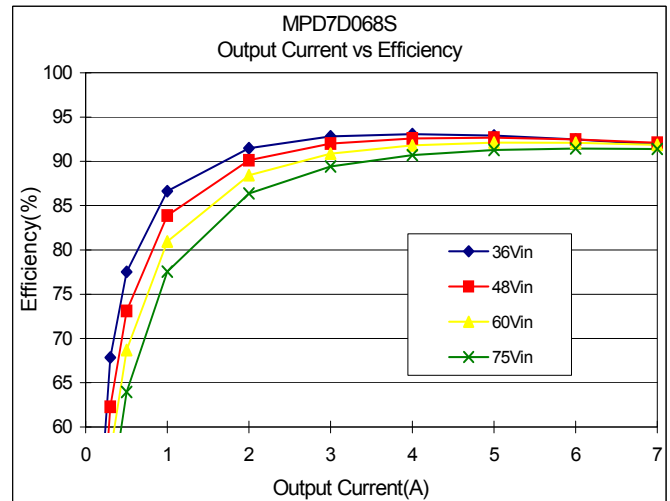


Fig.12-1-2 Output Current vs Efficiency

⚠ Note:

1. This datasheet is downloaded from the website of Murata Manufacturing co., Ltd. Therefore, it's specifications are subject to change or our products in it may be discontinued without advance notice. Please check with our sales representatives or product engineers before ordering.
2. This datasheet has only typical specifications because there is no space for detailed specifications. Therefore, please approve our product specifications or transact the approval sheet for product specifications before ordering.

12. External Input-Output Capacitor

<External Input capacitor>

When an inductance or a switch device are connected to the input line, and the transient response at the time of a sudden change of input power supply is bad, the input voltage is greatly changed at the time of a sudden change of DC-DC Converter.

Since the load response ability of DC-DC Converter may not be normally demonstrated by this influence, and DC-DC Converter may cause unusual oscillation in such a case, please connect an input capacitor.

<External output capacitor>

Applying an external output capacitor, the total output capacitance should be the following maximum external output capacitance or less.

Maximum External Output Capacitance: 400 μ F MAX

If you use an output capacitor that exceeds 400 μ F, please contact us.

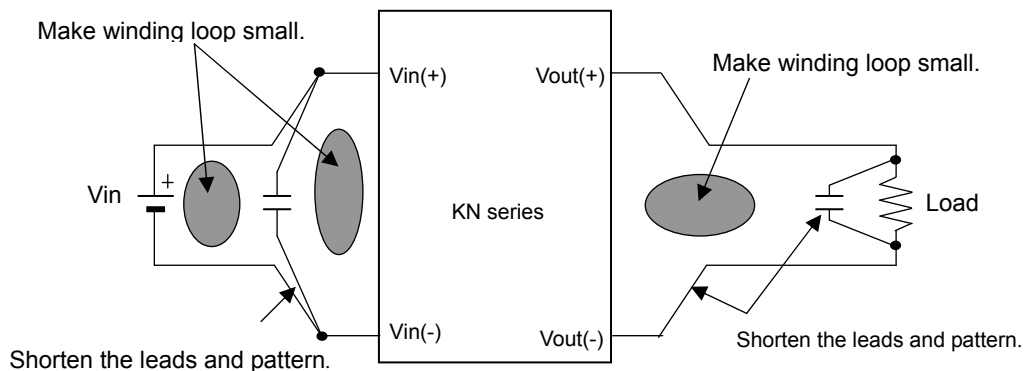
⚠ Caution

The above capacitance and electrical characteristics are guarantees on a condition in a measurement circuit by using a DC power supply.

When you connect an input inductance or an input power supply which has an output inductance, please confirm the operation including nearby circuits. Because it has the possibility that a DC-DC Converter causes unusual oscillation.

Input / output capacitor connections; in order to minimize noise, please consider the following items.

- ① Be sure to carry out a system characteristic check.
- ② Use a low impedance capacitor with good high frequency characteristics.
- ③ Shorten the leads of each capacitor as much as possible to minimize lead inductance.
- ④ Make the area of the wiring loop small in the input and output line to minimize leakage inductance.
- ⑤ Shorten the length of PCB pattern and widen patterns for the main circuit.



⚠ Note:

1. This datasheet is downloaded from the website of Murata Manufacturing Co., Ltd. Therefore, its specifications are subject to change or our products in it may be discontinued without advance notice. Please check with our sales representatives or product engineers before ordering.
2. This datasheet has only typical specifications because there is no space for detailed specifications. Therefore, please approve our product specifications or transact the approval sheet for product specifications before ordering.

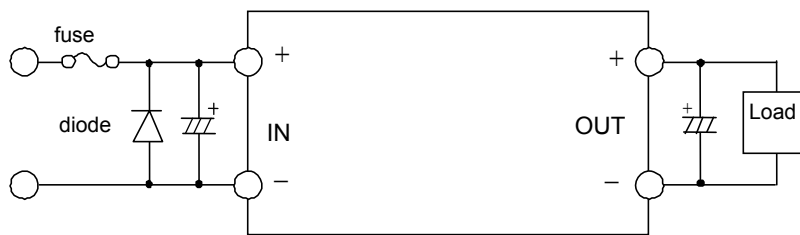
13. Caution

This product should not be operated parallel running and series running.

Please do not use a connector and a socket for connection with your board of this product. There is a possibility that it cannot be satisfied of a performance with the influence of contact resistance.

Be sure to provide an appropriate fail-safe function on your product to prevent a second damage that may be caused by the abnormal function or the failure of our product.

Please connect the input terminal by right polarity. If you connect this by mistake, it may break the DC-DC Converter. In the case of destruction of the DC-DC Converter inside, over input current may flow, and so DC-DC Converter maybe occurred abnormal temperature rise, or your product may be damaged. Please add diode and fuse as following to protect them.



Standard of fuse: current rating
MPD7D067S · MPD7D068S : 2[A]

* Please select Diode and Fuse after confirming the operation.

⚠ Note

1. Please contact our main sales office or nearby sales office before using our products for the applications listed below which require especially high reliability for the prevention of defects which might directly cause damage to the third party's life, body or property or this products for any other applications that described in the above.

- ① Aircraft equipment
- ② Aerospace equipment
- ③ Undersea equipment
- ④ Power plant control equipment
- ⑤ Medical equipment
- ⑥ Transportation equipment (vehicles, trains, ships, etc.)
- ⑦ Traffic signal equipment
- ⑧ Disaster prevention /crime prevention equipment
- ⑨ Data-processing equipment
- ⑩ Application of similar complexity and/or reliability requirements to the applications listed in the above.

2. This catalog is indicated in June, 2007. About the written contents, since changing without a preliminary announcement for improvement and supply are sometimes stopped, please confirm in case of ordering. If the written contents are unknown, please ask to our main sales office or nearby sales office.

3. Types and specification in this catalog are referenced for your information only.

Please confirm detailed specifications by approving our individual drawing and specification sheet.

⚠ Note:

1. This datasheet is downloaded from the website of Murata Manufacturing co., ltd. Therefore, it's specifications are subject to change or our products in it may be discontinued without advance notice. Please check with our sales representatives or product engineers before ordering.
2. This datasheet has only typical specifications because there is no space for detailed specifications. Therefore, please approve our product specifications or transact the approval sheet for product specifications before ordering.