

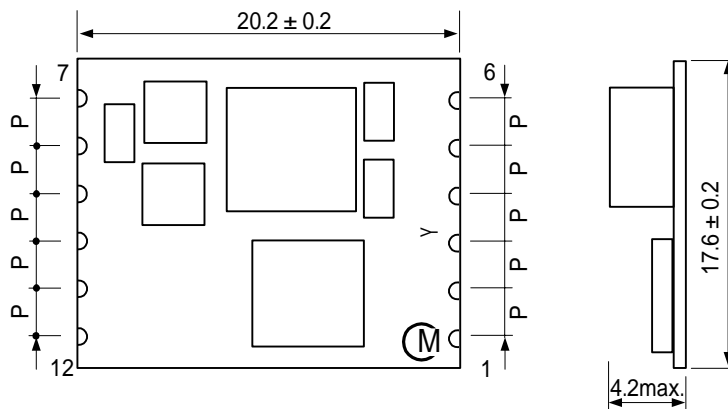
# DC-DC Converter Application Manual

## MPDRX307S,MPDRX308S

### 1. Features

- Ultra high-speed response is realized by using original ripple detecting control.
- Up to 6.5A output current, non-isolated POL.
- Wide adjustable output voltage range by connecting external resistance (0.8V to 1.65V / 1.6 to 3.63V).
- Wide operating temperature ( -40°C to +85°C ).
- UVLO function, ON/OFF function, Output voltage sense function, Over-current function and, PowerGood signal output function are built in.

### 2. Appearance, Dimensions



( )...reference value

P=2.54 ± 0.2mm

Tolerance is not accumulated.

#### Marking

(1) Pin No.1 Marking / MFG ID **M**

(2) Parts No. Y

D : MPDRX307S

E : MPDRX308S

(3) Lot No

Production Year

Production Month ( 1,2,3,...9,O,N,D )

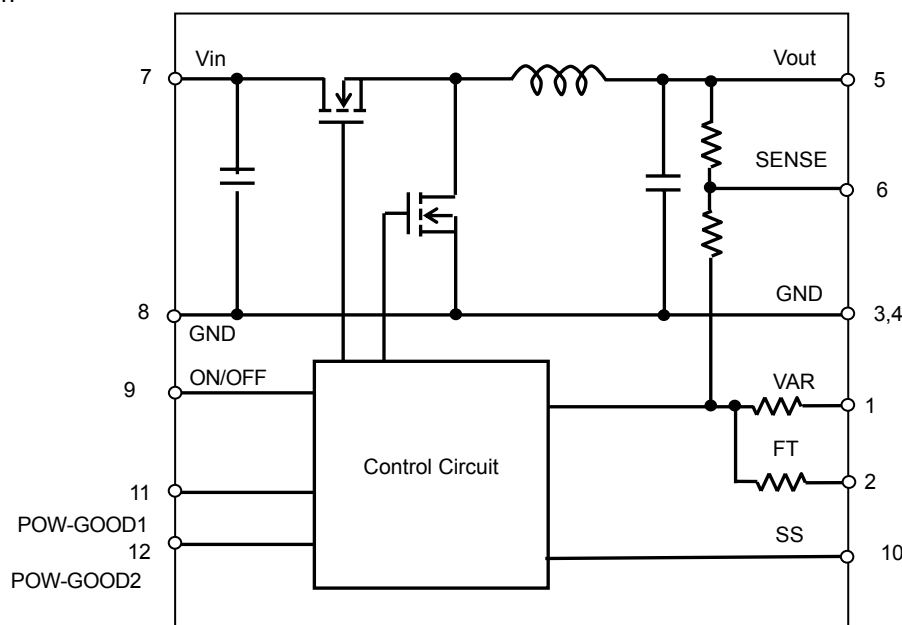
#### ⚠ Note:

1. This datasheet is downloaded from the website of Murata Manufacturing co., ltd. Therefore, it's specifications are subject to change or our products in it may be discontinued without advance notice. Please check with our sales representatives or product engineers before ordering.
2. This datasheet has only typical specifications because there is no space for detailed specifications. Therefore, please approve our product specifications or transact the approval sheet for product specifications before ordering.

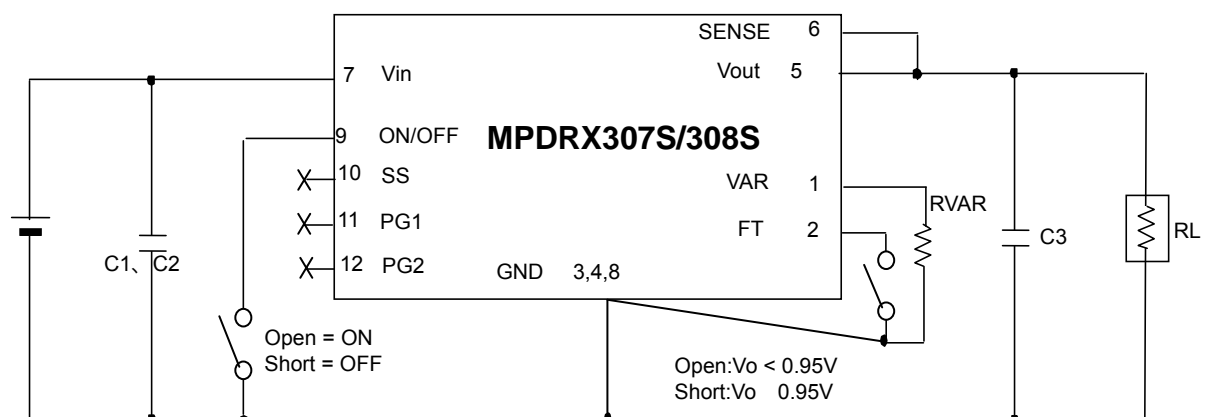
## Pin Number and Function

Pin No.	Symbol	Function
1	VAR	Vout Adjustment
2	FT	Output Trim
3,4	GND	GND
5	Vout	Output Voltage
6	SENSE	Output Voltage Sense
7	Vin	Input Voltage
8	GND	GND
9	ON/OFF	Remote ON/OFF
10	SS	Soft Start
11	POW-GOOD1	Power Good
12	POW-GOOD2	Power Good

## 3. Block Diagram



## 4. Test Circuit



C1,C2 : 10 $\mu$ F / 25V Ceramic Capacitor

C3, : 100 $\mu$ F / 6.3V Ceramic Capacitor

Please make sure to place C1 ,C2 and C3 nearby input and output terminal of DC-DC converter.

## ⚠ Note:

1. This datasheet is downloaded from the website of Murata Manufacturing co., ltd. Therefore, it's specifications are subject to change or our products in it may be discontinued without advance notice. Please check with our sales representatives or product engineers before ordering.
2. This datasheet has only typical specifications because there is no space for detailed specifications. Therefore, please approve our product specifications or transact the approval sheet for product specifications before ordering.

## 5. Characteristics

## 5. 1 Electrical Characteristics (Ta=25 °C)

## (1) MPDRX307S

Item	Symbol	Condition	Value			Unit	
			Min.	Typ.	Max.		
Input Voltage Range	Vin		6.2	9.6	13.2	V	
Rising UVLO Threshold	UVLOr	Vin Increasing	-	5.25	-	V	
Falling UVLO Threshold	UVLOf	Vin Decreasing	-	5.0	-	V	
Output Voltage Adjustable Range	Vout	FT=Short	1.6	-	3.63	V	
Output Voltage Tolerance	Vo tol	Over Vin, Io, Temperature Range Vin=6.2 ~ 13.2V Rset=1% tolerance, FT=Short	-2.0	-	+2.0	%Vo	
Output Current	Iout	See the thermal derating curve in section 5.2.	0	-	6.5	A	
Ripple Voltage	Vrpl	Vout =3.3V, Iout=0 ~ 6.5A BW=20MHz, Cout=100μF	-	10	50	mV(pp)	
Efficiency	EFF	Vin =9.6V, Iout=10A	Vout=3.3V	-	92	-	%
			Vout=2.5V	-	90	-	
			Vout=1.8V	-	88	-	
Operating Frequency	Frq	Vin =9.6V, Vout=3.3V	-	850	-	kHz	
		Vin =9.6V, Vout=1.8V	-	600	-		
Power Good	PWGL	Power Good low threshold	-	0.87Vo	-	V	
	PWGH	Power Good high threshold	-	1.13Vo	-		
ON/OFF pin High Voltage	VIH	ON/OFF pin is pulled up to Vin inside of the DC-DC converter. If ON/OFF pin is left open, the DC-DC converter shall be "ON". This pin will be pulled down to GND inside the DC-DC converter when UVLO events occur. Please do NOT connect this pin to power supply with low impedance line, so as not to damage the converter.					
ON/OFF pin Low Voltage	VIL	If ON/OFF pin is connected to GND, the DC-DC Converter shall be "OFF".	OFF	0	-	1.0	V
Short Circuit Protection	SCP	If output is shorted to GND, DC-DC converter will shut down. After reject the abnormal mode, DC-DC converter will restart by re-inputting Vin or toggling ON/OFFpin.					
External Input Capacitor	Cin	When input voltage is ideal voltage source	20	-	5000	μF	
External Output Capacitor	Cout	When input voltage is ideal voltage source	100	-	1000	μF	
Ramp Rate	Tr	Vo=10% ~ 90%, SS=Open	1	2	5	msec	
Rising Overshoot	Vover		-	0	+10	%	
Startup Delay	Td	ON/OFF High : Vin Low → High Vo=10% SS= Open	0.1	0.5	2	msec	
ON/OFF Startup Delay	Trcd	Vin High : ON/OFF Low → High/Open Vo=10%	0.1	0.4	2	msec	

## ⚠ Note:

- This datasheet is downloaded from the website of Murata Manufacturing co., ltd. Therefore, it's specifications are subject to change or our products in it may be discontinued without advance notice. Please check with our sales representatives or product engineers before ordering.
- This datasheet has only typical specifications because there is no space for detailed specifications. Therefore, please approve our product specifications or transact the approval sheet for product specifications before ordering.

## (2) MPDRX308S

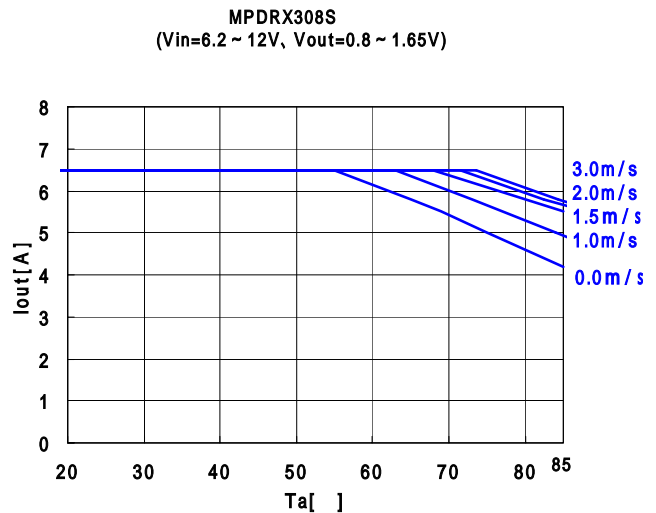
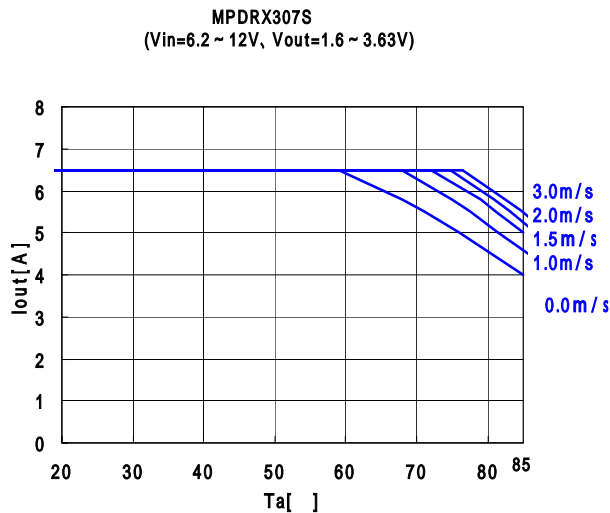
Item	Symbol	Condition	Value			Unit	
			Min.	Typ.	Max.		
Input Voltage Range	Vin		6.2	9.6	13.2	V	
Rising UVLO Threshold	UVLOr	Vin Increasing	-	5.25	-	V	
Falling UVLO Threshold	UVLOf	Vin Decreasing	-	5.0	-	V	
Output Voltage Adjustable Range	Vout	FT=Open	0.8	-	0.95	V	
		FT=Short	0.95	-	1.65		
Output Voltage Tolerance	Vo tol	Over Vin, Io, Temperature Range Vin=6.2 ~ 13.2V Rset=1% tolerance	Vout=0.8 ~ 0.95V FT=Open	-2.5	-	+2.5	%Vo
			Vout=0.95 ~ 1.65V FT=Short	-2.0	-	+2.0	
Output Current	Iout	See the thermal derating curve in section 5.2.	0	-	6.5	A	
Ripple Voltage	Vrpl	Vout =1.65V, Iout=0 ~ 13A BW=20MHz, Cout=100μF	-	10	50	mV(pp)	
Efficiency	EFF	Vin =9.6V, Iout=5A	Vout=1.5V	-	85	-	%
			Vout=1.2V	-	83	-	
			Vout=0.8V	-	79	-	
Operating Frequency	Frq	Vin =9.6V, Vout=1.5V	-	750	-	kHz	
		Vin =9.6V, Vout=0.8V	-	450	-		
Power Good	PWGL	Power Good low threshold	-	0.87Vo	-	V	
	PWGH	Power Good high threshold	-	1.13Vo	-		
ON/OFF pin High Voltage	VIH	ON/OFF pin is pulled up to Vin inside of the DC-DC converter. If ON/OFF pin is left open, the DC-DC converter shall be "ON". This pin will be pulled down to GND inside the DC-DC converter when UVLO events occur. Please do NOT connect this pin to power supply with low impedance line, so as not to damage the converter.					
ON/OFF pin Low Voltage	VIL	If ON/OFF pin is connected to GND, the DC-DC Converter shall be "OFF".	OFF	0	-	1.0	V
Short Circuit Protection	SCP	If output is shorted to GND, DC-DC converter will shut down. After reject the abnormal mode, DC-DC converter will restart by re-inputting Vin or toggling ON/OFF pin.					
External Input Capacitor	Cin	When input voltage is ideal voltage source	20	-	5000	μF	
External Output Capacitor	Cout	When input voltage is ideal voltage source	100	-	1000	μF	
Ramp Rate	Tr	Vo=10% ~ 90%, SS=Open	1	2	5	msec	
Rising Overshoot	Vover		-	0	+10	%	
Startup Delay	Td	ON/OFF High : Vin Low → High Vo=10%, SS= Open	0.1	0.5	2	msec	
ON/OFF Startup Delay	Trcd	Vin High : ON/OFF Low → High/Open Vo=10%	0.1	0.4	2	msec	

This DC-DC converter thermally shuts down when temperature of a control IC reaches to 180 °C typically.

⚠ **Note:**

1. This datasheet is downloaded from the website of Murata Manufacturing co., ltd. Therefore, it's specifications are subject to change or our products in it may be discontinued without advance notice. Please check with our sales representatives or product engineers before ordering.
2. This datasheet has only typical specifications because there is no space for detailed specifications. Therefore, please approve our product specifications or transact the approval sheet for product specifications before ordering.

## 5. 2 Thermal Derating



The above derating limits apply to this product soldered directly to 101.6\*180mm\*1.6mm PCB (Double-side with 70um copper). Any adjacent parts of high temperature may cause overheating. For reliable operation, please ensure that the FET temperature of this product is maintained below 120°C and the inductor temperature is below 106°C.

## 6. Pin Description

### 6.1. Adjusting the Output Voltage

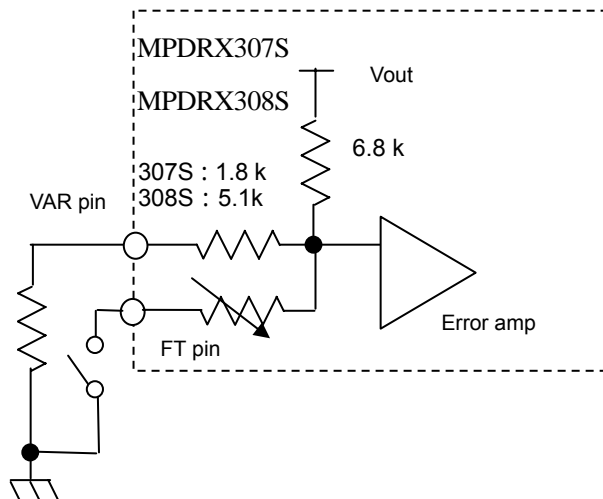
The output voltage can be adjusted by connecting resistors between VAR-pin(1Pin) to GND-pin.

The following equation gives the required external-resistor value to adjust the output voltage to Vo-adj.

It is highly recommended that evaluation of the characteristics of this DC-DC converter's operation under your board conditions be thoroughly conducted.

In case output voltage is used more than 0.95V, please connect FT-pin(2pin) to GND.

### Internal Circuit



MPDRX307S (FT-pin : SHORT to GND)

$$R_{VAR} = \frac{5440}{V_{o-adj}[V] \times 1.002 - 1.5[V]} - 1800 \quad [ \Omega ]$$

MPDRX308S

(a) 0.8 Vout < 0.95V (FT-pin : OPEN)

$$R_{VAR} = \frac{5440}{V_{o-adj}[V] \times 1.002 - 0.8[V]} - 5100 \quad [ \Omega ]$$

(b) 0.95 Vout 1.65V (FT-pin : SHORT to GND)

$$R_{VAR} = \frac{5440}{V_{o-adj}[V] \times 1.002 - 0.95[V]} - 5100 \quad [ \Omega ]$$

### ⚠ Note:

1. This datasheet is downloaded from the website of Murata Manufacturing co., ltd. Therefore, it's specifications are subject to change or our products in it may be discontinued without advance notice. Please check with our sales representatives or product engineers before ordering.
2. This datasheet has only typical specifications because there is no space for detailed specifications. Therefore, please approve our product specifications or transact the approval sheet for product specifications before ordering.

## &lt;RVAR calculation example&gt;

## MPDRX307S

Voadj [V]	Calculated RVAR[ ]	FT pin (8pin)
3.63	745	Short to GND
3.3	1211	Short to GND
2.5	3613	Short to GND
1.8	16118	Short to GND
1.6	50913	Short to GND

## MPDRX308S

Voadj [V]	Calculated RVAR[ ]	FT pin (8pin)
1.65	2635	Short to GND
1.5	4737	Short to GND
1.2	16453	Short to GND
1.0	99515	Short to GND
0.95	2858058	Short to GND
0.9	48338	Open
0.8	3394900	Open

## 6.2 ON/OFF Control

## ON/OFF function

Using the ON/OFF feature, the operation of this product can be disabled without removal of the input voltage. Sequencing of a power supply system and power-saving control can be easily achieved using this function.

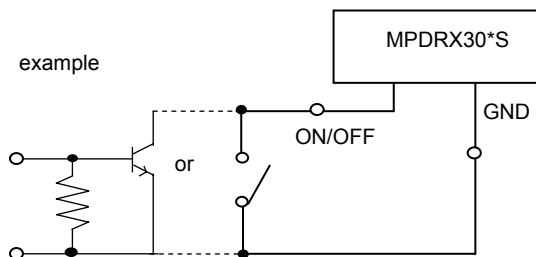
## ON/OFF Control Operation

When ON/OFF-pin(13pin) is left open

When ON/OFF-pin(13pin) is connected to GND

..... Output Voltage =ON

..... Output Voltage=OFF

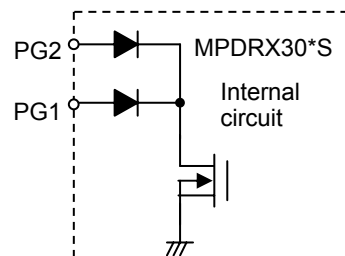


## 6.3. Power Good

Powergood signal is appeared within the value of clause 5.1. (Open-drain output)

Output voltage is within voltage detection threshold: POW-GOOD is open.

Output Voltage is out of voltage detection threshold : POW-GOOD is connected to GND.

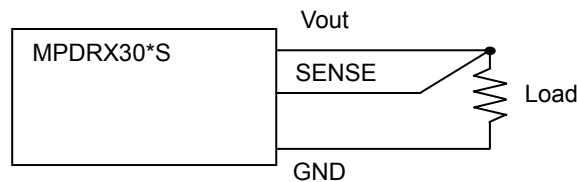


## ⚠ Note:

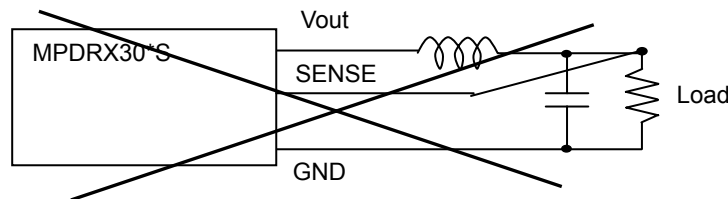
1. This datasheet is downloaded from the website of Murata Manufacturing co., ltd. Therefore, it's specifications are subject to change or our products in it may be discontinued without advance notice. Please check with our sales representatives or product engineers before ordering.
2. This datasheet has only typical specifications because there is no space for detailed specifications. Therefore, please approve our product specifications or transact the approval sheet for product specifications before ordering.

#### 6.4. Output Voltage Sensing

By connecting the SENSE-pin to the load, the output voltage drop due to the PCB wiring may be compensated for (within 10cm).



Please do NOT connect SENSE-pin to the output of LC filter that is set to the Vout line. When using this way, this product will not operate properly.

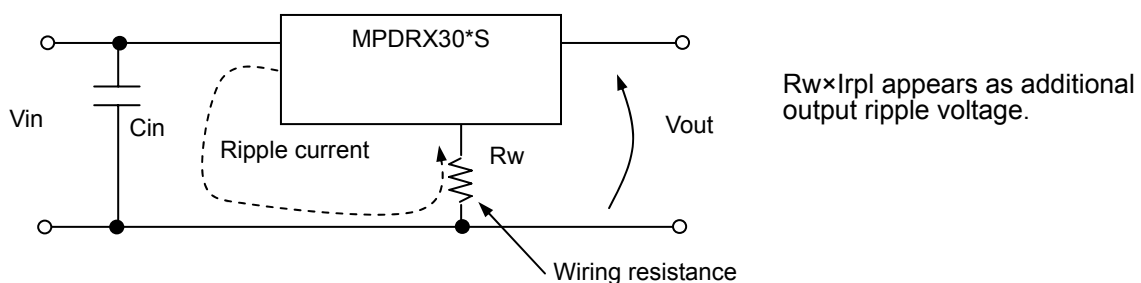


#### 6.5. Input External capacitor

It is recommended to connect a low-impedance electrolytic capacitor of 20 $\mu$ F or more at Vin terminal. Smaller input capacitor may lead to an unstable operation of this product caused by input voltage fluctuation. Please check the proper operation of it on your product when smaller input capacitor is used.

Using ceramic capacitors as input capacitor may cause an increase of output voltage, because input ripple current flows through the external input capacitor and wiring resistance.

This phenomenon is affected by the position of external capacitors, the value of external capacitors and voltage difference between Vin and Vout. Using low-impedance electrolytic capacitor will ease this problem. Please check the proper operation of it on your product when ceramic input capacitor is used.



#### 6.6. Output External capacitor

Ceramic capacitors are recommended as output external capacitor. Using ceramic capacitors, small output variation and small ripple voltage are realized.

Output capacitor should be within 100 $\mu$ F to 1000 $\mu$ F. Output capacitor shall be placed near the output terminal. When using plural capacitors, please make sure to place a capacitor of at least 100 $\mu$ F near the output terminal, and place other capacitors near the load.

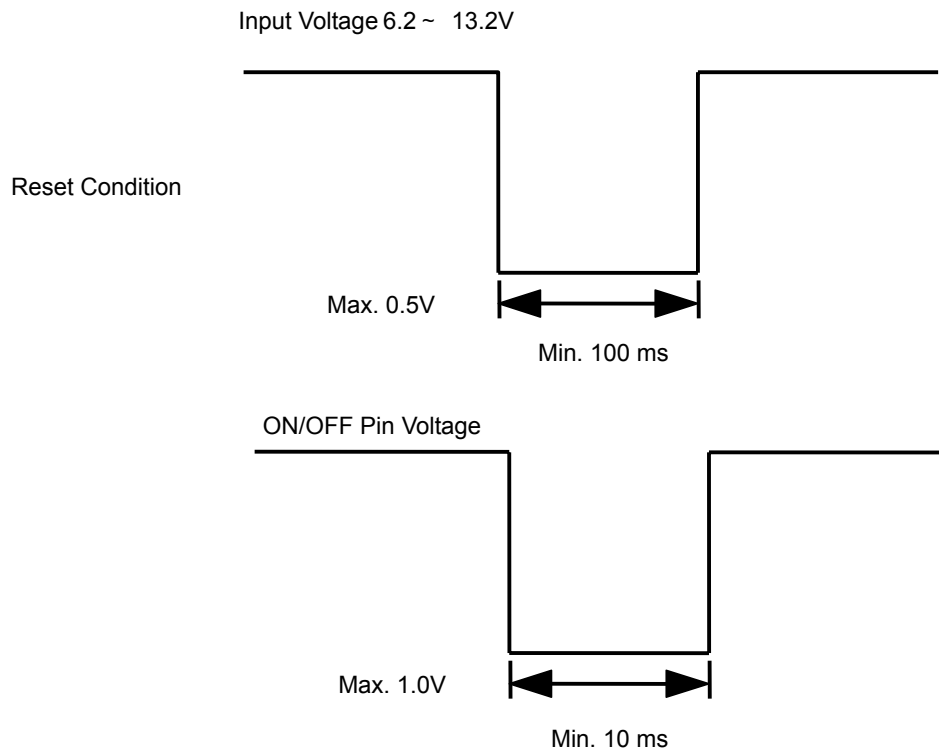
When using LC output filter, please make sure to place a capacitor of at least 100 $\mu$ F near the output terminal.

#### ⚠ Note:

1. This datasheet is downloaded from the website of Murata Manufacturing co., ltd. Therefore, it's specifications are subject to change or our products in it may be discontinued without advance notice. Please check with our sales representatives or product engineers before ordering.
2. This datasheet has only typical specifications because there is no space for detailed specifications. Therefore, please approve our product specifications or transact the approval sheet for product specifications before ordering.

### 6.7. Reset Condition

In order to reset all function, the input Voltage is set under 0.5V for Min.100 m second or ON/OFF pin voltage is set under 1.0V for Min 10m second.



**⚠ Note:**

1. This datasheet is downloaded from the website of Murata Manufacturing co., ltd. Therefore, it's specifications are subject to change or our products in it may be discontinued without advance notice. Please check with our sales representatives or product engineers before ordering.
2. This datasheet has only typical specifications because there is no space for detailed specifications. Therefore, please approve our product specifications or transact the approval sheet for product specifications before ordering.

## 7. Typical Characteristics Data

### 7.1 Load Transient Response

Our original ripple-detective control method achieves much better load transient responses.

$V_{in}=9.6V$ ,  $V_o=2.5V$ (MPDRX307S, Fig.7-1a),  $1.2V$ (MPDRX308S, Fig.7-1b)

$I_o=5A \rightarrow 0A$ ,  $di/dt=5A/\mu s$ ,  $C_{out}=100\mu F$ (Ceramic),  $T_a=25^\circ C$

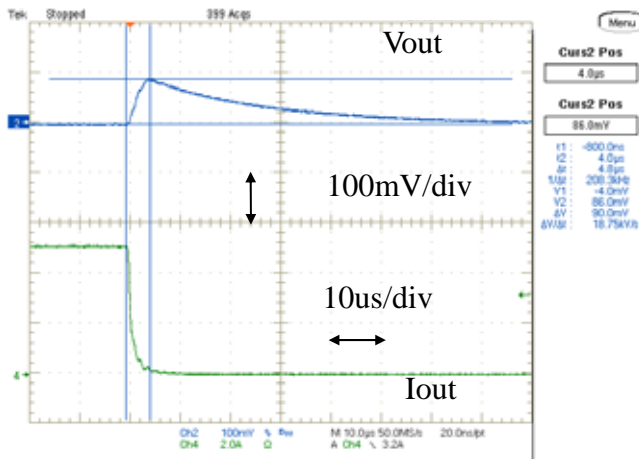


Fig.7-1a. Load Transient Response (MPDRX307S)

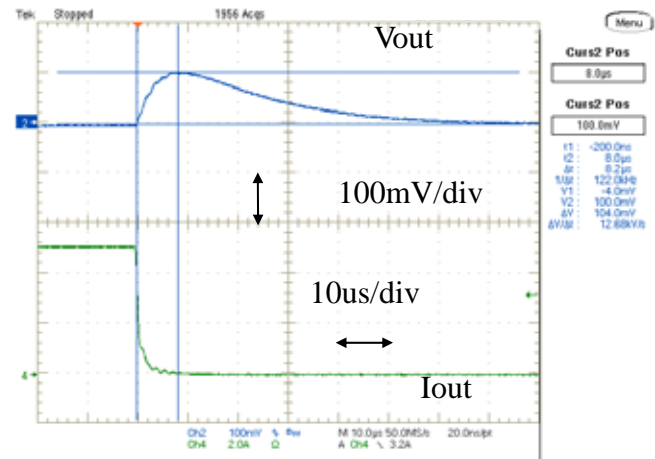


Fig.7-1b. Load Transient Response (MPDRX308S)

### 7.2 Output Impedance characteristics

Our original ripple-detective control method achieves very low output impedance in wide frequency range.

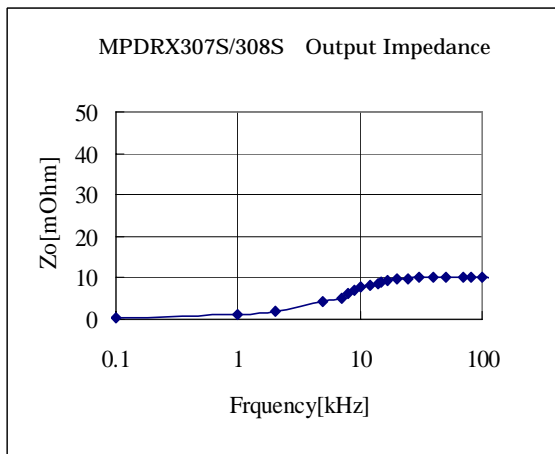


Fig.7-2-1. Output Impedance of MPDRX307S/308S

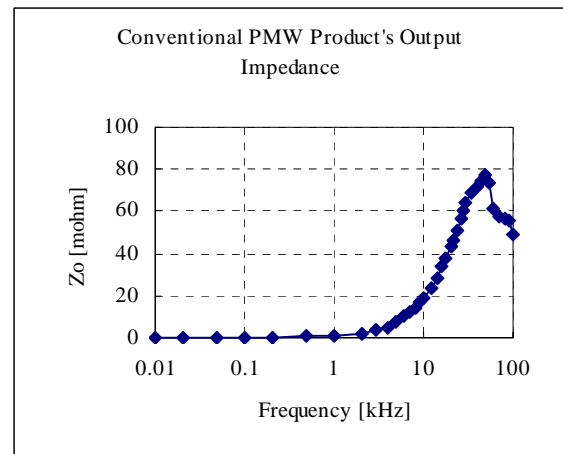


Fig.7-2-2. Output Impedance of conventional product

#### ⚠ Note:

1. This datasheet is downloaded from the website of Murata Manufacturing co., ltd. Therefore, it's specifications are subject to change or our products in it may be discontinued without advance notice. Please check with our sales representatives or product engineers before ordering.
2. This datasheet has only typical specifications because there is no space for detailed specifications. Therefore, please approve our product specifications or transact the approval sheet for product specifications before ordering.

## 7. 3 Other electrical characteristics

7.3.1.  $V_{out}=3.3V$  (MPDRX307S)

( $T_a=25^\circ C$ ,  $C_{in}=GRM32DR71E106KA12L \times 2$ ,  $C_{out}=GRM32EB30J107ME16$ ,  $R_{VAR}=1211\Omega$ )

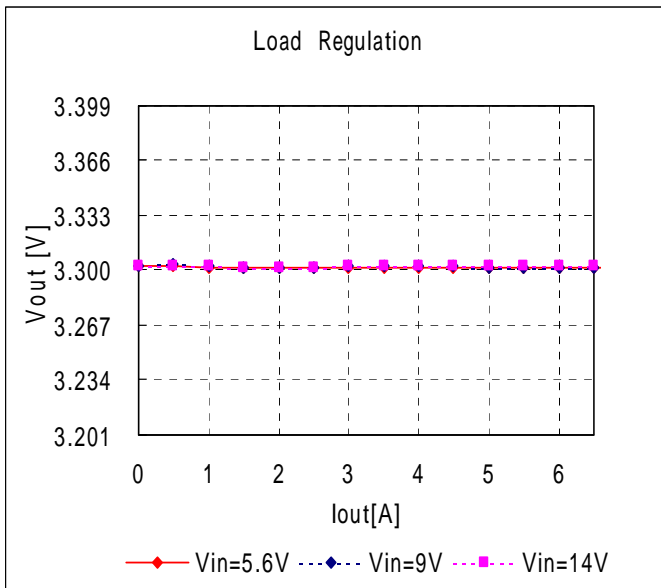


Fig.7-3-1. Output Voltage v.s. Output Current

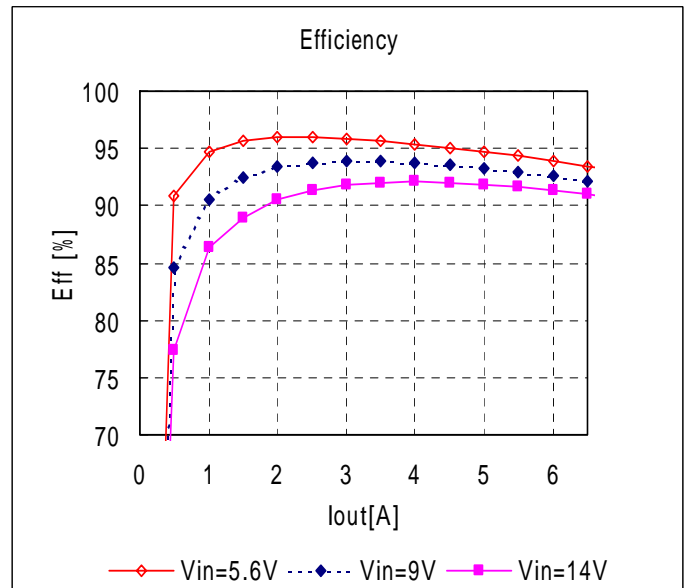


Fig.7-3-2. Efficiency v.s. Output Current

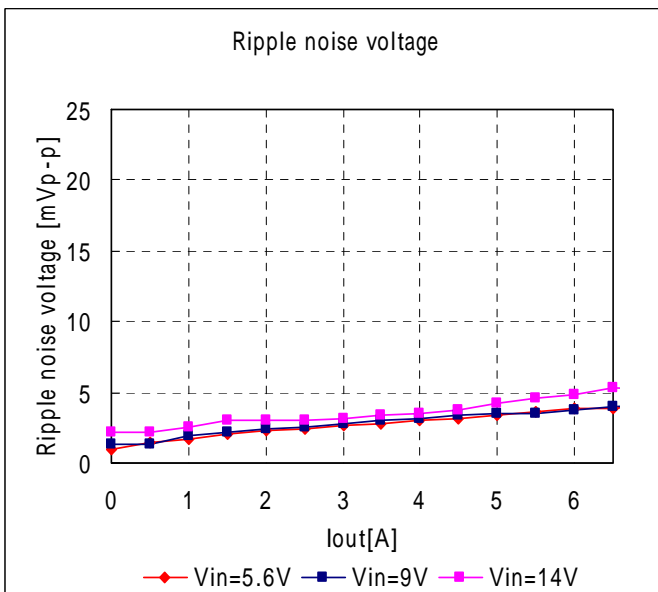


Fig.7-3-3. Ripple Voltage v. s. Output Current

## ⚠ Note:

1. This datasheet is downloaded from the website of Murata Manufacturing co., ltd. Therefore, it's specifications are subject to change or our products in it may be discontinued without advance notice. Please check with our sales representatives or product engineers before ordering.
2. This datasheet has only typical specifications because there is no space for detailed specifications. Therefore, please approve our product specifications or transact the approval sheet for product specifications before ordering.

## 7.3.2. Vout=2.5V (MPDRX307S)

( Ta=25°C, Cin= GRM32DR71E106KA12L×2, Cout= GRM32EB30J107ME16, RVAR=3613Ω )

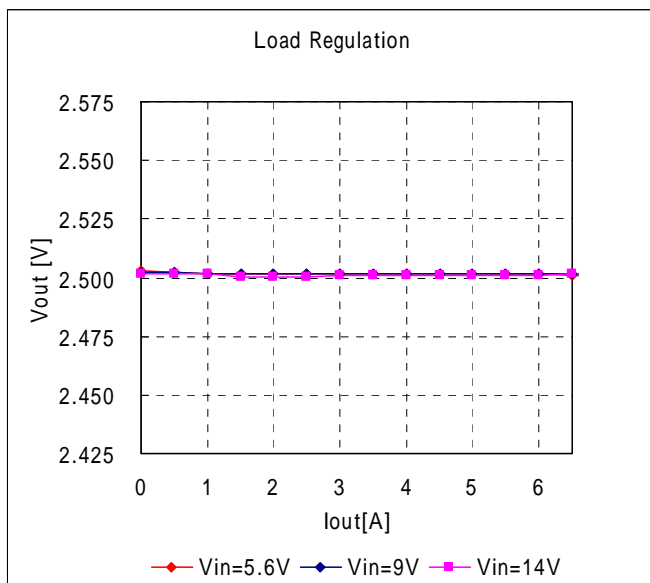


Fig.7-3-4. Output Voltage v.s. Output Current

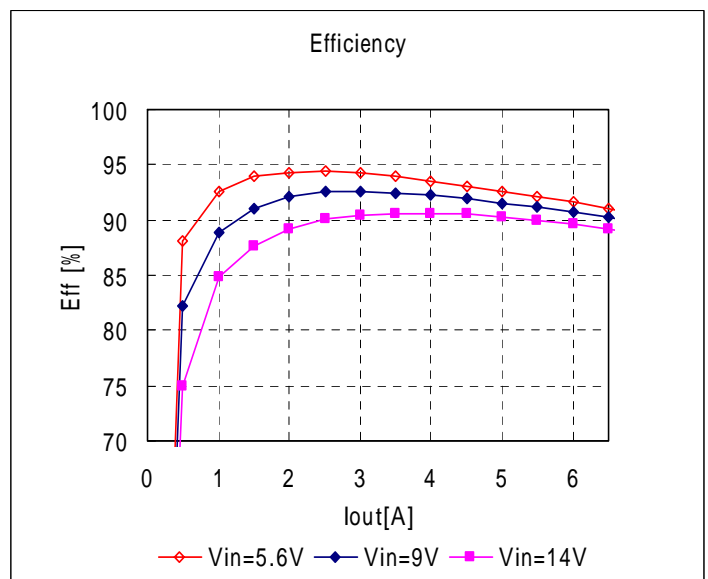


Fig.7-3-5. Efficiency v.s. Output Current

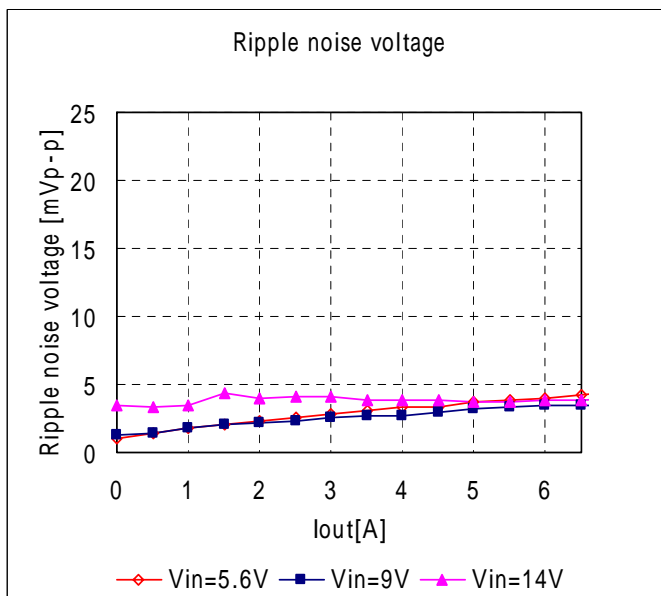


Fig.7-3-6. Ripple Voltage v. s. Output Current

## ⚠ Note:

1. This datasheet is downloaded from the website of Murata Manufacturing co., ltd. Therefore, it's specifications are subject to change or our products in it may be discontinued without advance notice. Please check with our sales representatives or product engineers before ordering.
2. This datasheet has only typical specifications because there is no space for detailed specifications. Therefore, please approve our product specifications or transact the approval sheet for product specifications before ordering.

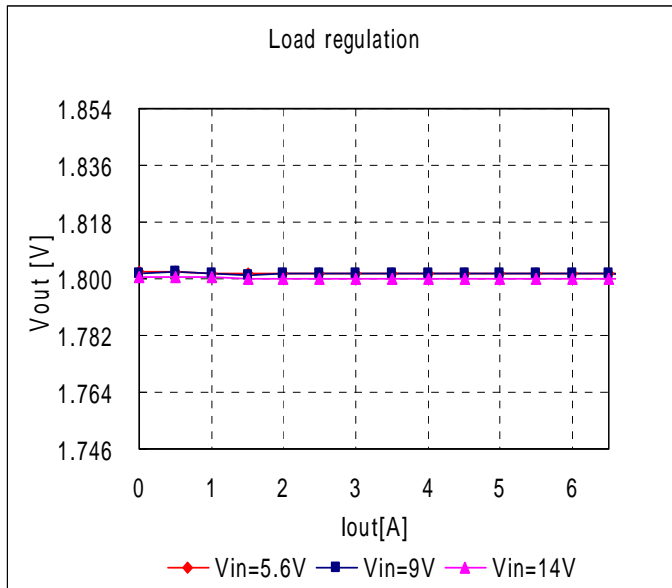
7.3.3.  $V_{out}=1.8V$  (MPDRX307S)(  $T_a=25^{\circ}C$ ,  $C_{in}= GRM32DR71E106KA12L \times 2$ ,  $C_{out}= GRM32EB30J107ME16$ ,  $R_{VAR}=16118\Omega$  )

Fig.7-3-7. Output Voltage v.s. Output Current

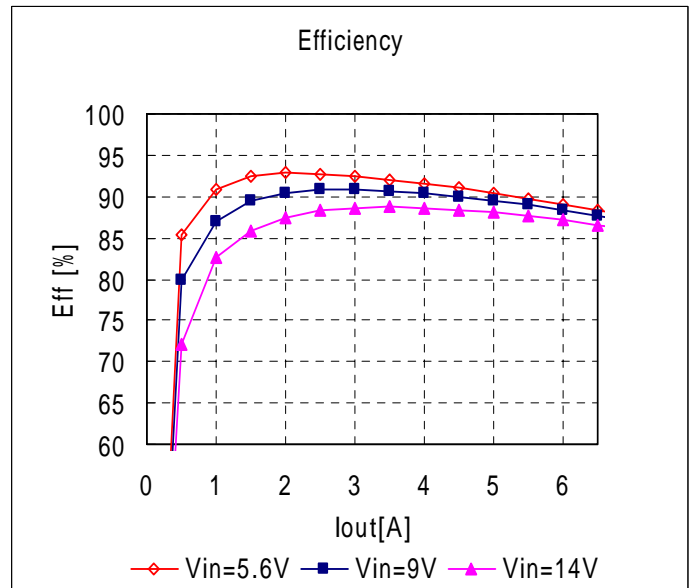


Fig.7-3-8. Efficiency v.s. Output Current

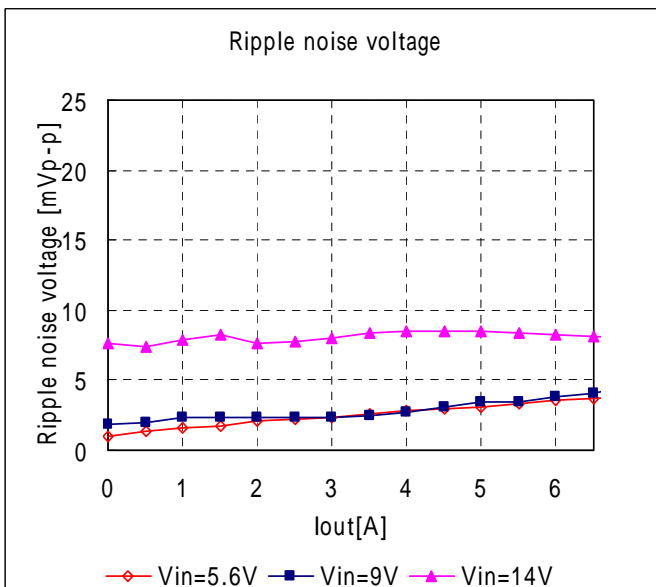


Fig.7-3-9. Ripple Voltage v. s. Output Current

## ⚠ Note:

1. This datasheet is downloaded from the website of Murata Manufacturing co., ltd. Therefore, it's specifications are subject to change or our products in it may be discontinued without advance notice. Please check with our sales representatives or product engineers before ordering.
2. This datasheet has only typical specifications because there is no space for detailed specifications. Therefore, please approve our product specifications or transact the approval sheet for product specifications before ordering.

## 7.3.4. Vout=1.5V (MPDRX308S)

( Ta=25 °C, Cin= GRM32DR71E106KA12L×2, Cout= GRM32EB30J107ME16, RVAR=4737Ω )

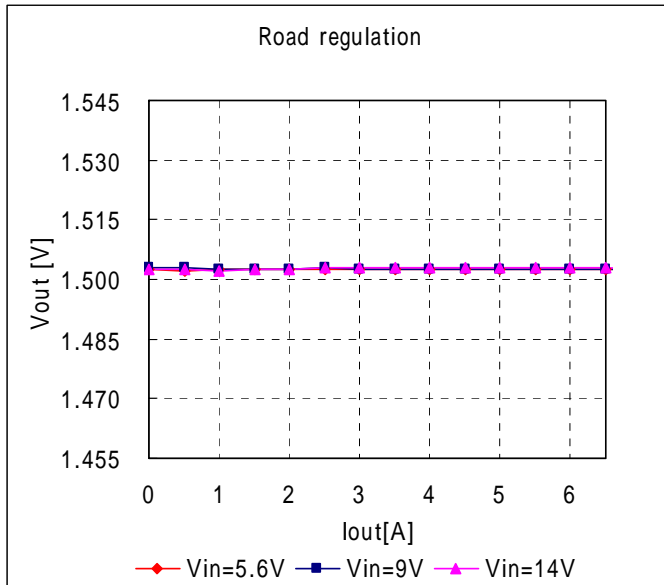


Fig.7-3-10. Output Voltage v.s. Output Current

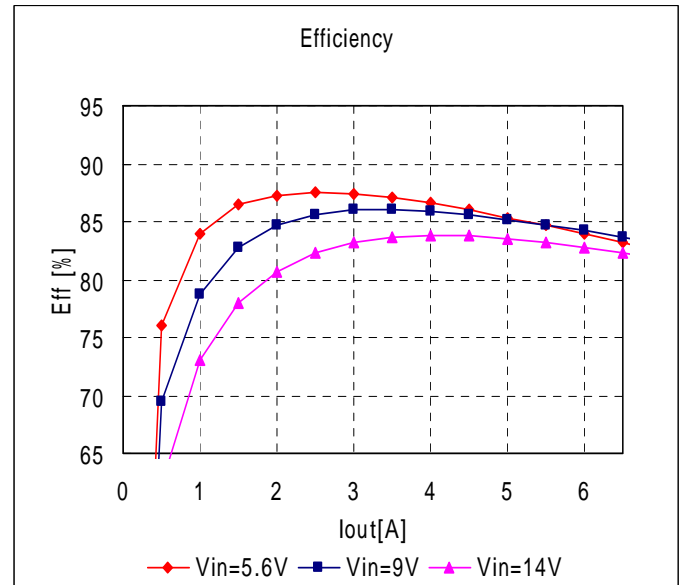


Fig.7-3-11. Efficiency v.s. Output Current

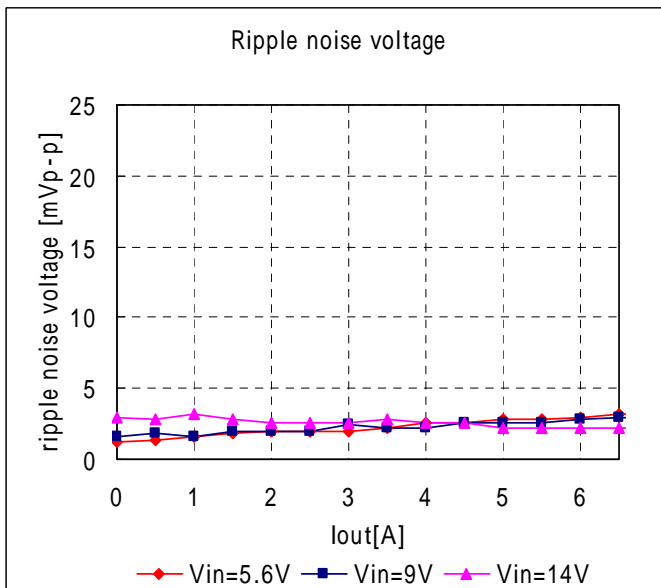


Fig.7-3-12. Ripple Voltage v. s. Output Current

## ⚠ Note:

1. This datasheet is downloaded from the website of Murata Manufacturing co., ltd. Therefore, it's specifications are subject to change or our products in it may be discontinued without advance notice. Please check with our sales representatives or product engineers before ordering.
2. This datasheet has only typical specifications because there is no space for detailed specifications. Therefore, please approve our product specifications or transact the approval sheet for product specifications before ordering.

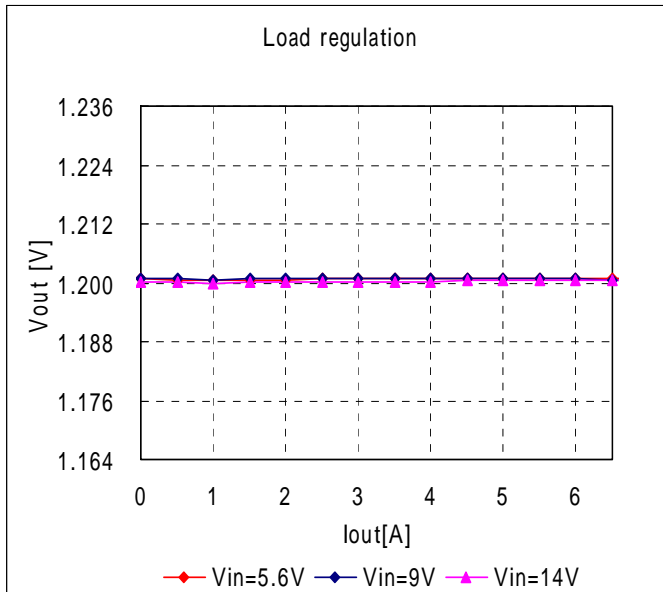
7.3.5.  $V_{out}=1.2V$  (MPDRX308S)(  $T_a=25^{\circ}C$ ,  $C_{in}= GRM32DR71E106KA12L \times 2$ ,  $C_{out}= GRM32EB30J107ME16$ ,  $R_{VAR}=16453\Omega$  )

Fig.7-3-13. Output Voltage v.s. Output Current

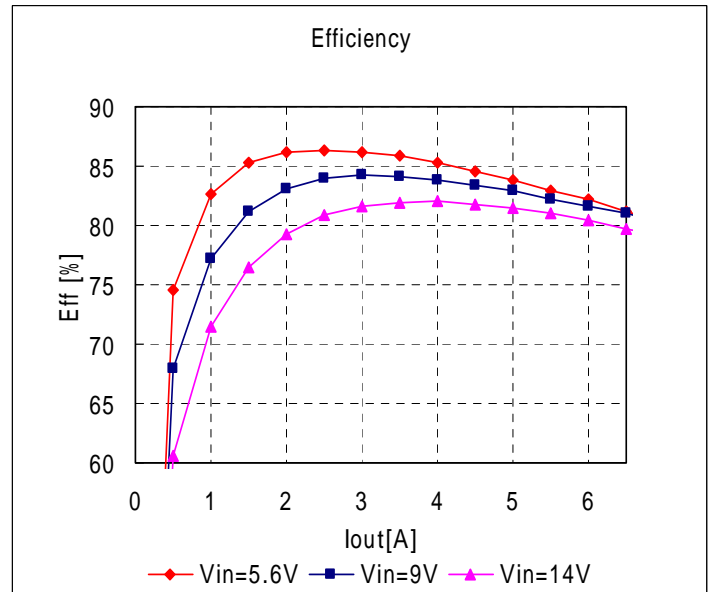


Fig.7-3-14. Efficiency v.s. Output Current

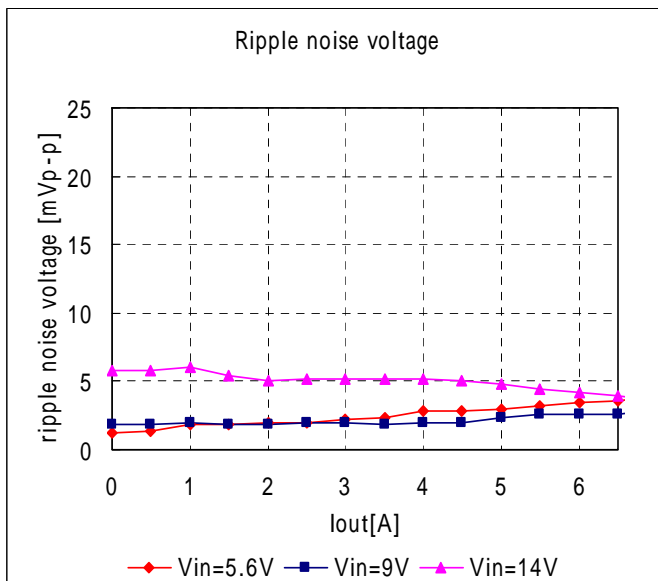


Fig.7-3-15. Ripple Voltage v. s. Output Current

## ⚠ Note:

1. This datasheet is downloaded from the website of Murata Manufacturing co., ltd. Therefore, it's specifications are subject to change or our products in it may be discontinued without advance notice. Please check with our sales representatives or product engineers before ordering.
2. This datasheet has only typical specifications because there is no space for detailed specifications. Therefore, please approve our product specifications or transact the approval sheet for product specifications before ordering.

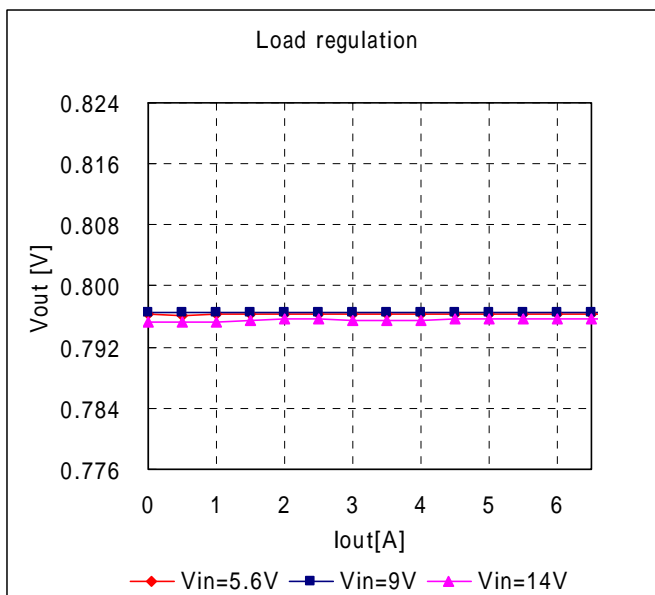
7.3.6.  $V_{out}=0.8V$  (MPDRX308S)(  $T_a=25^{\circ}C$ ,  $C_{in}= GRM32DR71E106KA12L \times 2$ ,  $C_{out}= GRM32EB30J107ME16$ ,  $R_{VAR}=3394900\Omega$  )

Fig.7-3-16. Output Voltage v.s. Output Current

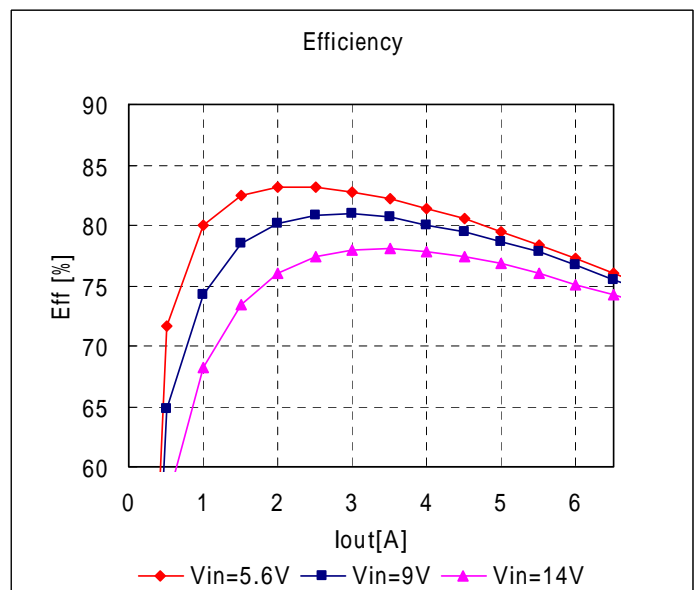


Fig.7-3-17. Efficiency v.s. Output Current

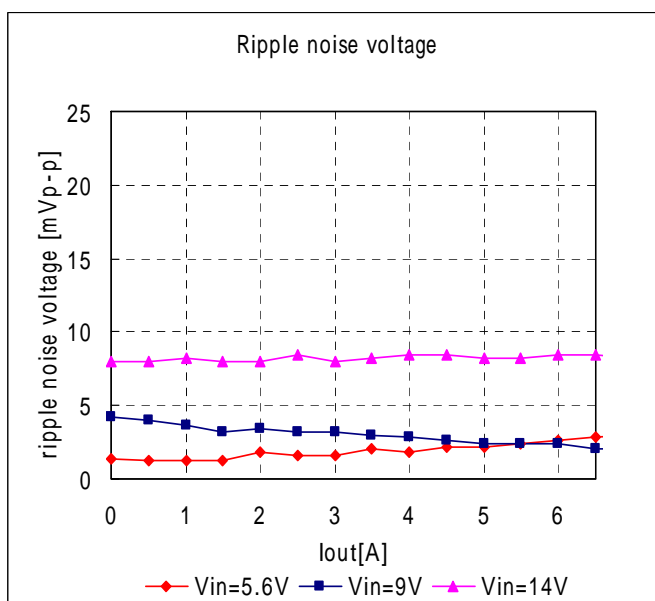


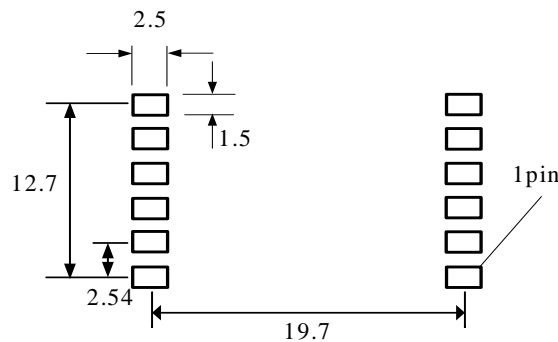
Fig.7-3-18. Ripple Voltage v. s. Output Current

## ⚠ Note:

1. This datasheet is downloaded from the website of Murata Manufacturing co., ltd. Therefore, it's specifications are subject to change or our products in it may be discontinued without advance notice. Please check with our sales representatives or product engineers before ordering.
2. This datasheet has only typical specifications because there is no space for detailed specifications. Therefore, please approve our product specifications or transact the approval sheet for product specifications before ordering.

## 8. Mounting Condition

## 8. 1 PCB Land Pattern Recommendation



## 8. 2 Recommended Soldering Conditions

## Reflow Soldering

This product is RoHS compliant. The following profile is recommended for the reflow of this product using Pb-free solder paste (Sn-Ag-Cu).

Method : Full convection reflow soldering

## Reflow Soldering Profile

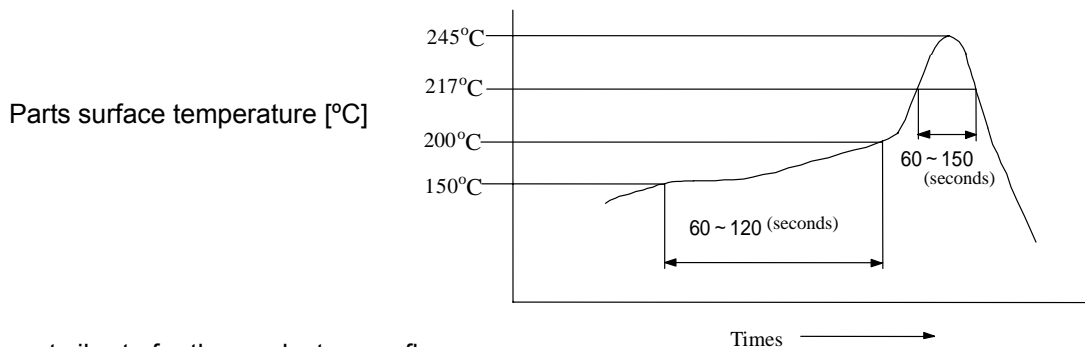
JEDEC IPC/JEDEC J-STD-020D

Table 5-2 Classification Reflow Profile

Pb-Free Assembly Large Body

## Profile details

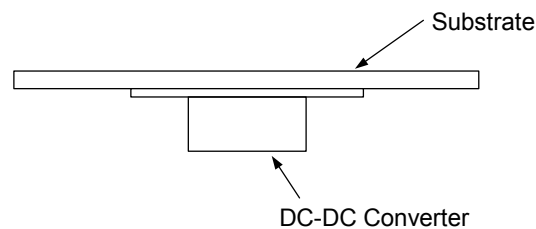
Soldering temperature	: 245°C+0/-5°C
Soldering time	: 30 seconds, 240 to 245°C
Heating time	: 60 to 150 seconds, over 217°C
Preheating time	: 60 to 120 seconds, 150 to 200°C
Programming rate	: 3°C/ sec. Max., 217 to 245°C
Descending rate	: 6°C/ sec. Max.
Total soldering time	: 8 minutes Max., 25 to 245°C
Times	: 1 time



Do not vibrate for the products on reflow.

Please need to take care temperature control because mounted parts may come off if the product are left under the high temperature.

Do not reflow DC-DC converter as follows, because DC-DC converter may fall down from a substrate during reflowing.



## ⚠ Note:

1. This datasheet is downloaded from the website of Murata Manufacturing co., ltd. Therefore, it's specifications are subject to change or our products in it may be discontinued without advance notice. Please check with our sales representatives or product engineers before ordering.
2. This datasheet has only typical specifications because there is no space for detailed specifications. Therefore, please approve our product specifications or transact the approval sheet for product specifications before ordering.

## 9. Notice

### Input / Output capacitor

Both input-side and output side, please make the wiring loop between plus and minus as small as possible. The influence of a leakage inductance can be reduced. Please make the power line pattern as wide and short as possible.

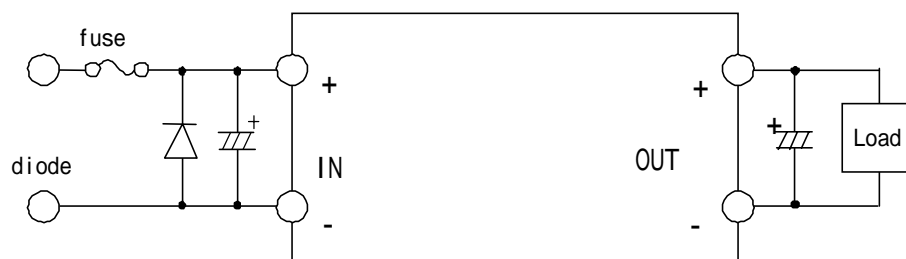
This product should not be operated in parallel or in series.

Please do not use a connector or a socket to connect this product to your product. The electric characteristics may be deteriorated by the influence of contact resistance.

Be sure to provide an appropriate fail-safe function on your product to prevent secondary damage that may be caused due to abnormal functional or failure of this product.

Inrush current protection is not a feature of this product.

Please connect the input terminals with the correct polarity. If an error in polarity connection is made this product may be damaged. If this product is damaged internally, an elevated input current may flow, and so this product may exhibit an abnormal temperature rise, or your product may be damaged. Please add a diode and fuse per the following diagram to protect them.



Please select diode and fuse after confirming the operation of your product.



### Note

Please contact our main sales office or nearby sales office before using our products for the applications listed below which require especially high reliability for the prevention of defects which might directly cause damage to the third party's life, body or property or this products for any other applications that described in the above.

Aircraft equipment  
 Aerospace equipment  
 Undersea equipment  
 Power plant control equipment  
 Medical equipment  
 Transportation equipment (vehicles, trains, ships, etc.)  
 Traffic signal equipment  
 Disaster prevention /crime prevention equipment  
 Data-processing equipment  
 Application of similar complexity and/or reliability requirements to the applications listed in the above.

- This catalog is indicated in March 2009. About the written contents, since changing without a preliminary announcement for improvement and supply are sometimes stopped, please confirm in case of ordering. If written contents are unknown, please ask to our main sales office or nearby sales office.
- Types and specification in this catalog are referenced for your information only. Please confirm detailed specifications by approving our individual drawing and specification sheet.

### Note:

- This datasheet is downloaded from the website of Murata Manufacturing co., ltd. Therefore, it's specifications are subject to change or our products in it may be discontinued without advance notice. Please check with our sales representatives or product engineers before ordering.
- This datasheet has only typical specifications because there is no space for detailed specifications. Therefore, please approve our product specifications or transact the approval sheet for product specifications before ordering.