

DC-DC Converter Application Manual

MPDTH03060W**

10-A, 3.3-V Input Non-Isolated Wide-Output Adjust Power Module



NOMINAL SIZE = 25.3 mm x 15.75 mm

Features

- Up to 10-A Output Current
- 3.3-V Input Voltage
- Wide-Output Voltage Adjust (0.8 V to 2.5 V)
- Efficiencies up to 96 %
- 114 W/in³ Power Density
- On/Off Inhibit
- Output Voltage Sense
- Pre-Bias Startup
- Margin Up/Down Controls
- Under-Voltage Lockout
- Auto-Track™ Sequencing
- Output Over-Current Protection (Non-Latching, Auto-Reset)
- Operating Temp: -40 to +85 °C
- Point-of-Load Alliance Compatible

Description

The MPDTH03060W non-isolated power module is small in size but big on performance and flexibility. Its high output current, compact footprint, and industry leading features offers system designers a versatile module for powering complex multi-processor digital systems.

This product employs double-sided surface mount construction and provides high-performance step-down power conversion for up to 10 A of output current from a 3.3-V input bus voltage. The output voltage is adjustable and can be set to any value over the range, 0.8 V to 2.5 V, using a single resistor. This series includes Auto-Track™ Sequencing.

Auto-Track simplifies the task of supply voltage sequencing in a power system by enabling modules to track each other, or any external voltage, during power up and power down.

Other operating features include an on/off inhibit, margin up/down controls, and the ability to start up into an existing output voltage or prebias. To ensure tight load regulation, an output voltage sense is also provided. A non-latching overcurrent trip serves as load fault protection.

Target applications include complex multi-voltage, multi-processor systems that incorporate the industry's high-speed DSPs, micro-processors and bus drivers.

Pin Configuration

Pin	Function
1	GND
2	Vin
3	Inhibit
4	Vo Adjust
5	Vo Sense
6	Vout
7	GND
8	Track
9	Margin Down
10	Margin Up

Standard Application

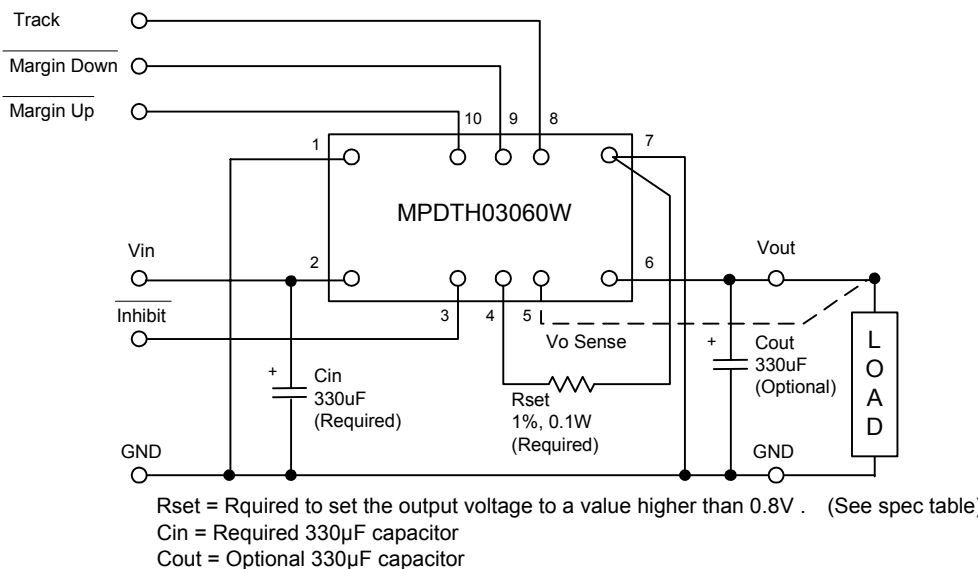

⚠ Note:

1. This datasheet is downloaded from the website of Murata Manufacturing co., ltd. Therefore, it's specifications are subject to change or our products in it may be discontinued without advance notice. Please check with our sales representatives or product engineers before ordering.
2. This datasheet has only typical specifications because there is no space for detailed specifications. Therefore, please approve our product specifications or transact the approval sheet for product specifications before ordering.

10-A, 3.3-V Input Non-Isolated Wide-Output Adjust Power Module

Ordering Information

Output Voltage (MPDTH03060□xx)		Package Options (MPDTH03060x□□)	
Code	Voltage	Code	Description
W	0.8V-2.5V(Adjustable)	AH	Horiz. T/H
		AS	SMD(*1)

Notes (1) Pb free (Sn-Ag-Cu) pin solder material.

Pin Description

Vin: The positive input voltage power node to the module, which is referenced to common *GND*.

Vout: The regulated positive power output with respect to the *GND* node.

GND: This is the common ground connection for the *Vin* and *Vout* power connections. It is also the 0 VDC reference for the control inputs.

Inhibit: The Inhibit pin is an open-collector/drain negative logic input that is referenced to *GND*. Applying a low level ground signal to this input disables the module's output and turns off the output voltage. When the *Inhibit* control is active, the input current drawn by the regulator is significantly reduced. If the *Inhibit* pin is left open circuit, the module will output voltage whenever a valid input source is applied.

Vo Adjust: A 0.1 W 1 % resistor must be directly connected between this pin and pin7 (*GND*) to set the output voltage to a value higher than 0.8 V. The temperature stability of the resistor should be 100 ppm/°C (or better). The set-point range for the output voltage is from 0.8 V to 2.5 V. The resistor value required for a given output voltage can be calculated from the following formula. If this pin is left open circuit, the output voltage will default to its lowest value. For further information on output voltage adjustment see the related application note.

$$R_{set} = 10 \text{ k}\Omega \cdot \frac{0.8\text{V}}{V_{out}-0.8\text{V}} - 2.49 \text{ k}\Omega$$

The specification table gives the preferred resistor values for a number of standard output voltages.

Vo Sense: The sense input allows the regulation circuit to compensate for voltage drop between the module and the load. For optimal voltage accuracy *Vo Sense* should be connected to *Vout*. It can also be left disconnected.

Track: This is an analog control input that enables the output voltage to follow an external voltage. This pin becomes active typically 20 ms after the input voltage has been applied, and allows direct control of the output voltage from 0 V up to the nominal set-point voltage. Within this range the output will follow the voltage at the *Track* pin on a volt-for-volt basis. When the control voltage is raised above this range, the output voltage is regulated at its set-point voltage. This feature allows the output voltage to rise simultaneously with other modules powered from the same input bus. If unused, the input should be connected to *Vin*.

Note: Due to the under-voltage lockout feature, the output of the module cannot follow its own input voltage during power up. For more information, see the related application note.

Margin Down: When this input is asserted to *GND*, the output voltage is decreased by 5% from the nominal. The input requires an open-collector (open-drain) interface. It is not TTL compatible. A lower percent change can be accommodated with a series resistor. If unused, this input may be left unconnected. For further information, consult the related application note.

Margin Up: When this input is asserted to *GND*, the output voltage is increased by 5%. The input requires an open-collector (open-drain) interface. It is not TTL compatible. The percent change can be reduced with a series resistor. If unused, this input may be left unconnected. For further information, consult the related application note.

⚠ Note:

1. This datasheet is downloaded from the website of Murata Manufacturing co., ltd. Therefore, it's specifications are subject to change or our products in it may be discontinued without advance notice. Please check with our sales representatives or product engineers before ordering.
2. This datasheet has only typical specifications because there is no space for detailed specifications. Therefore, please approve our product specifications or transact the approval sheet for product specifications before ordering.

10-A, 3.3-V Input Non-Isolated Wide-Output Adjust Power Module

Environmental & Absolute Maximum Ratings (Voltages are with respect to GND)

Characteristics	Symbols	Conditions	Min	Typ	Max	Units
Track Input Voltage	V _{track}		-0.3	-	V _{in} +0.3	V
Operating Temperature Range	T _a	Over V _{in} Range	-40 ⁽ⁱ⁾	-	85	°C
Storage Temperature	T _s		-40		125	°C
Solder Reflow Temperature	T _{reflow}	Surface temperature of module body or pins			245 ⁽ⁱⁱ⁾	°C

Notes: (i) For operation below 0 °C the external capacitors must have stable characteristics. Use either a low ESR tantalum, Os-Con, or ceramic capacitor.

(ii) During reflow of SMD package version do not elevate peak temperature of the module, pins or internal components above the stated maximum.

Specifications (Unless otherwise stated, T_a =25 °C, V_{in} =3.3 V, V_{out} =2.5 V, C_{in} =330µF, C_{out} =0µF, and I_o =I_omax)

Characteristics	Symbols	Conditions	MPDTH03010W			Units	
			Min	Typ	Max		
Output Current	I _o	0.8V ≤ V _o ≤ 2.5V, 60°C 200LFM Airflow 25°C Natural Convection	0	-	10 ⁽¹⁾	A	
Input Voltage Range	V _{in}	Over I _o Range	2.95 ⁽²⁾	-	3.65	V	
Set-Point Voltage Tolerance	V _{o tol}		-	-	±2 ⁽³⁾	%V _o	
Temperature Variation	ΔRegtemp	-40°C <T _a < +85°C	-	±0.5	-	%V _o	
Line Regulation	ΔRegline	Over V _{in} Range	-	±10	-	mV	
Load Regulation	ΔRegload	Over I _o Range	-	±12	-	mV	
Total Output Variation	ΔRegtot	Includes set-point, line, load, -40°C <T _a < +85°C	-	-	±3 ⁽³⁾	%V _o	
Efficiency	η	I _o =7A	RSET = 2.21 kΩ V _o = 2.5 V	-	93	-	%
			RSET = 4.12 kΩ V _o = 2.0 V	-	92	-	
			RSET = 5.49 kΩ V _o = 1.8 V	-	91	-	
			RSET = 8.87kΩ V _o = 1.5 V	-	89	-	
			RSET =17.4 kΩ V _o = 1.2 V	-	87	-	
		RSET = 36.5 kΩ V _o = 1.0 V	-	85	-		
V _o Ripple (pk-pk)	V _r	20 MHz bandwidth, C _{o2} =10µF ceramic	-	25	-	mVpp	
Short Circuit Protection	I _o trip	Reset, Followed by Auto-Recovery	-	20	-	A	
Transient Response	t _{tr} ΔV _{tr}	1 A/µs load step, 50 to 100 % I _o max C _{out} =330µF	Recovery Time	-	70	-	µsec
			V _o deviation	-	100	-	mV
Margin Up/Down Adjust	ΔV _o margin		-	±5	-	%	
Margin Input Current (pin 9/10)	I _{IL} margin	Pin to GND	-	-8 ⁽⁴⁾	-	µA	
Track Input Current (pin 8)	I _{IL} track	Pin to GND	-	-	-130 ⁽⁵⁾	µA	
Track Slew Rate Capability	dV _{track} /dt	C _{out} ≤C _{out} (max)	-	-	1	V/ms	
Rising UVLO Threshold	UVLO _r	V _{in} increasing	-	2.45	2.8	V	
Falling UVLO Threshold	UVLO _f	V _{in} decreasing	1.9	2.1	-	V	
Inhibit Control (pin4)	V _{IH} V _{IL}	Referenced to GND	V _{in} -0.5	-	Open ⁽⁵⁾	V	
			-0.2	-	0.6		
	I _{IL} inhibit	Pin to GND	-	-130	-	µA	
Input Standby Current	I _{in} inh	Inhibit (pin 3) to GND, Track (pin 8) open	-	10	-	mA	
Switching Frequency	Frq	Over V _{in} and I _o Ranges	275	300	325	kHz	
External Input Capacitance	C _{in}	Capacitance Non-Ceramic(ESR ≥4mΩ) Ceramic	330 ⁽⁶⁾	-	-	µF	
			0	330 ⁽⁷⁾	5500 ⁽⁸⁾	µF	
			0	-	300		
MTBF	MTBF	Per Bellcore TR-332 50 % stress, T _a =40°C, Ground Benign	5.7	-	-	10 ⁶ Hrs	

Notes: (1) See SOA curves or consult factory for appropriate derating.

(2) The minimum input voltage is equal to 2.95 V or V_{out} + 0.65 V, whichever is greater.

(3) The set-point voltage tolerance is affected by the tolerance and stability of RSET. The stated limit is unconditionally met if RSET has a tolerance of 1 % with 100 ppm/°C or better temperature stability.

(4) A small low-leakage (<100 nA) MOSFET is recommended to control this pin. The open-circuit voltage is less than 1 Vdc.

(5) This control pin has an internal pull-up to the input voltage V_{in}. If it is left open-circuit the module will operate when input power is applied. A small low-leakage (<100 nA) MOSFET is recommended for control. For further information, consult the related application note.

(6) A 330µF input capacitor is required for proper operation. The capacitor must be rated for a minimum of 500 mA rms of ripple current.

(7) An external output capacitor is not required for basic operation. Adding 330µF of distributed capacitance at the load will improve the transient response.

(8) This is the calculated maximum. The minimum ESR limitation will often result in a lower value. Consult the application notes for further guidance.

⚠ Note:

- This datasheet is downloaded from the website of Murata Manufacturing co., ltd. Therefore, it's specifications are subject to change or our products in it may be discontinued without advance notice. Please check with our sales representatives or product engineers before ordering.
- This datasheet has only typical specifications because there is no space for detailed specifications. Therefore, please approve our product specifications or transact the approval sheet for product specifications before ordering.

**10-A, 3.3-V Input Non-Isolated
Wide-Output Adjust Power Module**

Characteristic Data; Vin =3.3 V (See Note A)

Safe Operating Area; Vin =3.3 V (See Note B)

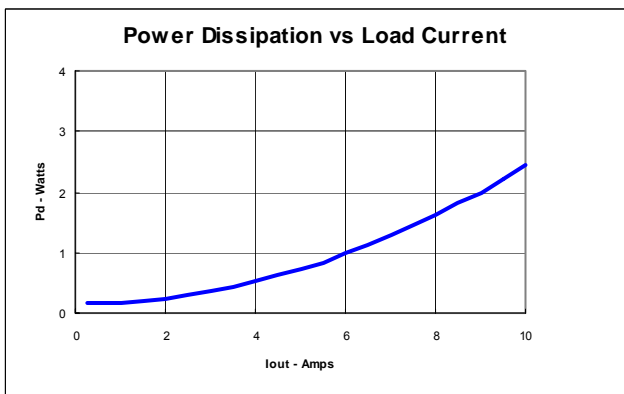
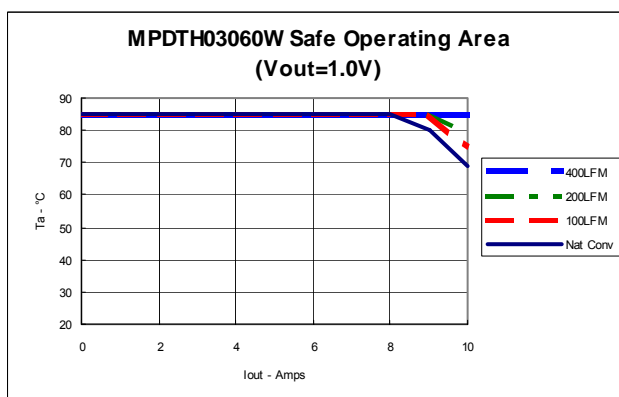
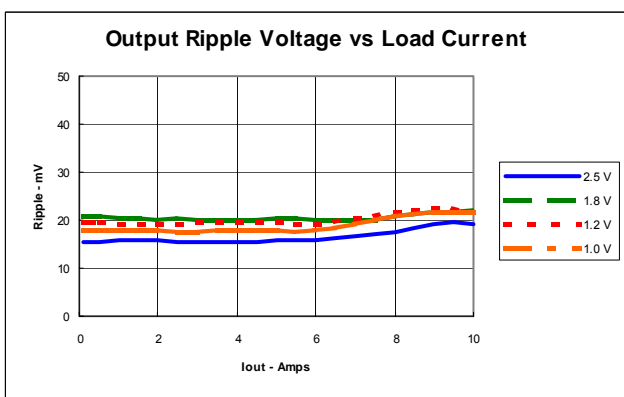
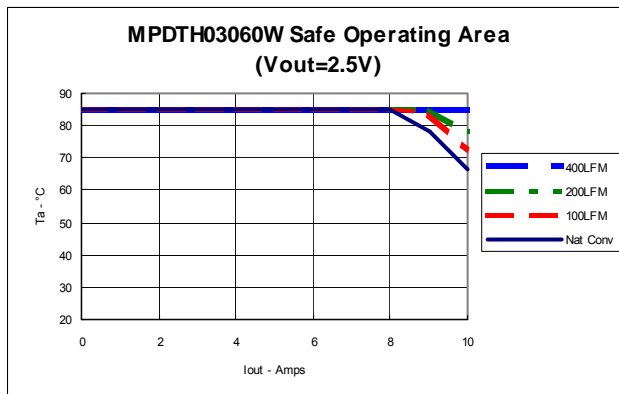
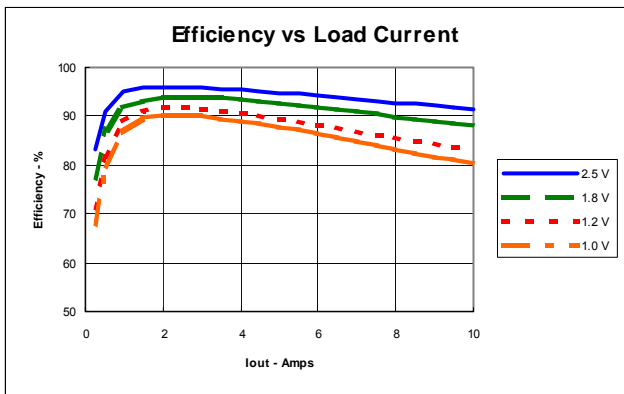

Note A: Characteristic data has been developed from actual products tested at 25°C. This data is considered typical data for the Converter.
 Note B: SOA curves represent the conditions at which internal components are at or below the manufacturer's maximum operating temperatures. Derating limits apply to modules soldered directly to a 4 in.x4in. 4-layer PCB with 1 oz. copper.

⚠ Note:

1. This datasheet is downloaded from the website of Murata Manufacturing co., ltd. Therefore, it's specifications are subject to change or our products in it may be discontinued without advance notice. Please check with our sales representatives or product engineers before ordering.
2. This datasheet has only typical specifications because there is no space for detailed specifications. Therefore, please approve our product specifications or transact the approval sheet for product specifications before ordering.

MPDTH03060W & MPDTH05060W

Capacitor Recommendations for the MPDTH03060 & MPDTH05060 Series of Power Modules**Input Capacitor**

The recommended input capacitor(s) is determined by the 330 μ F minimum capacitance and 500 mArms minimum ripple current rating.

Ripple current, less than 150 m Ω equivalent series resistance (ESR), and temperature are the major considerations when selecting input capacitors. Unlike polymer tantalum, regular tantalum capacitors have a recommended minimum voltage rating of 2 \times (maximum DC voltage + AC ripple). This is standard practice to ensure reliability.

For improved ripple reduction on the input bus, ceramic capacitors may be used to complement electrolytic types and achieve the minimum required capacitance.

Output Capacitors (Optional)

For applications with load transients (sudden changes in load current), regulator response will benefit from an external output capacitance. The recommended output capacitance of 330 μ F will allow the module to meet its transient response specification (see product data sheet). For most applications, high quality computer-grade aluminum electrolytic capacitors are adequate. These capacitors provide decoupling over the frequency range, 2 kHz to 150 kHz, and are suitable when ambient temperatures above 0 $^{\circ}$ C. For operation below 0 $^{\circ}$ C tantalum, ceramic or Os-Con type capacitors are recommended. When using one or more non-ceramic capacitors, the calculated equivalent ESR should not be lower than 4 m Ω (7 m Ω using the manufacturer's maximum ESR for a single capacitor). A list of preferred low-ESR type capacitors are listed on Table 1-1.

Ceramic Capacitors

Above 150 kHz the performance of aluminum electrolytic capacitors becomes less effective. To further improve the reflected input ripple current or the output transient response, multilayer ceramic capacitors can also be added. Ceramic capacitors have very low ESR and their resonant frequency is higher than the bandwidth of the regulator. When used on the output their combined ESR is not critical as long as the total value of ceramic capacitance does not exceed 300 μ F. Also, to prevent the formation of local resonance, do not place more than five identical ceramic capacitors in parallel with values of 10 μ F or greater.

Tantalum Capacitors

Tantalum type capacitors can be used at both the input and output, and are recommended for applications where the ambient operating temperature can be less than 0 $^{\circ}$ C. The AVX TPS, Sprague 593D/594/595 and Kemet T495/T510 capacitor series are recommended over many other tantalum types due to their higher rated surge, power dissipation, and ripple current capability.

As a caution many general purpose tantalum capacitors have considerably higher ESR, reduced power dissipation and lower ripple current capability. These capacitors are also less reliable as they have reduced power dissipation and surge current ratings. Tantalum capacitors that do not have a stated ESR or surge current rating are not recommended for power applications.

When specifying Os-Con and polymer tantalum capacitors for the output, the minimum ESR limit will be encountered well before the maximum capacitance value is reached.

Capacitor Table

Table 1-1 identifies the characteristics of capacitors from a number of vendors with acceptable ESR and ripple current (rms) ratings. The recommended number of capacitors required at both the input and output buses is identified for each capacitor type.

This is not an extensive capacitor list. Capacitors from other vendors are available with comparable specifications. Those listed are for your reference. The RMS ripple current rating and ESR (at 100kHz) are critical parameters necessary to insure both optimum regulator performance and long capacitor life.

Designing for Very Fast Load Transients

The transient response of the DC/DC Converter has been characterized using a load transient with a di/dt of 1A/ μ s. The typical voltage deviation for this load transient is given in the data sheet specification table using the optional value of output capacitance. As the di/dt of a transient is increased, the response of a converter's regulation circuit ultimately depends on its output capacitor decoupling network. This is an inherent limitation with any DC/DC Converter once the speed of the transient exceeds its bandwidth capability. If the target application specifies a higher di/dt or lower voltage deviation, the requirement can only be met with additional output capacitor decoupling. In these cases special attention must be paid to the type, value and ESR of the capacitors selected.

If the requirements of transient performance exceed what are specified in the data sheet, or the total amount of load capacitance is above 3,000 μ F, the selection of output capacitors becomes more important. For further guidance, please consult us.

⚠ Note:

1. This datasheet is downloaded from the website of Murata Manufacturing co., ltd. Therefore, it's specifications are subject to change or our products in it may be discontinued without advance notice. Please check with our sales representatives or product engineers before ordering.
2. This datasheet has only typical specifications because there is no space for detailed specifications. Therefore, please approve our product specifications or transact the approval sheet for product specifications before ordering.

MPDTH03060W & MPDTH05060W

Table 1-1; Input / Output Capacitors

Capacitor Vendor, Type Series (Style)	Capacitor Characteristics					Quantity		Vendor Number
	Working Voltage	Value (uF)	MAX.(ESR) at 100kHz	Max.Ripple at 85°C Current(Irms)	Physical Size(mm)	Input Bus	Output Bus	
Panasonic, Aluminum FC (Radial)	10V	330	0.117Ω	555 mA	8×10	1	1	EEUFC1A331
FK (SMD)	25V	470	0.080Ω	850 mA	10×10.2	1	1	EEVFK1E471P
FC (SMD)	16V	330	0.150Ω	670 mA	10×10.2	1	1	EEVFC1C331P
United Chemi-Con PXA, Poly-Alum(SMD)	10V	330	0.024Ω	3770 mA	10×7.7	1	≦4	PXA10VC331MJ80TP
PS, Poly-Alum (Radial)	6.3V	390	0.012Ω	4770 mA	8×11.5	1	≦2	6PS390MH11
FX, Os-con(Radial)	10V	390	0.018Ω	3710 mA	8×10.5	1	≦3	10FX390M
LXZ, Aluminum (Radial)	16V	330	0.120Ω	555 mA	8×12.5	1	1	LXZ16VB331M8X12LL
Nichicon, Aluminum WG, (SMD)	25V	330	0.150Ω	670 mA	10×10	1	1	UWG1E331MNR1GS
HD, (Radial)	16V	330	0.072Ω	760 mA	8×11.5	1	1	UHD1A331MPR
PM, (Radial)	16V	330	0.120Ω	625 mA	10×12.5	1	1	UPM1C331MPH6
Panasonic, Poly-Aluminum WA, (SMD)	10V	330	0.022Ω	4500 mA	10×10.2	1	≦4	EEFWA1A331P
S/SE, (SMD)	6.3V	180	0.005Ω	4000 mA	7.3×4.3×4.2	2	1	EEFSE0J181R
Sanyo SP, Os-con(Radial)	10V	470	0.015Ω	4500 mA	10×10.5	1	≦2	10SP470M
SVP, Os-con(SMD)	10V	330	0.017Ω	3950 mA	8×12	1	≦3	10SVP330M
TPE Poscap (SMD)	6.3V	330	0.025Ω	2400 mA	7.3×4.3	1	≦4	6TPE330ML
AVX, Tantalum TPS (SMD)	10V	330	0.045Ω	1723 mA	7.3L	1	≦5	TPSE337M010R0045
	10V	330	0.060Ω	1826 mA	×5.7W ×4.1H	1	≦5	TPSV337M010R0060
Kemet T520, (SMD)	10V	330	0.040Ω	1800 mA	7.3L ×4.3W	1	1	T520X337M010AS
T530, (SMD)	10V	330	0.015Ω	>3800 mA	×4.0H	1	1	T530X337M010AS
Vishay-Sprague 595D, Tantalum (SMD)	10V	330	0.100Ω	1040 mA	7.2L×	1	≦5	595D337X0010D2T
594D, Tantalum (SMD)	10V	330	0.045Ω	2360 mA	6W×4.1H	1	≦5	594D337X0016R2T
94SA, Poly-Alum (Radial)	6.3V	330	0.025Ω	3500 mA	10×10.5	1	≦4	94SA337X06R3FBP
Kemet, Ceramic X5R(SMD)	16V	10	0.002Ω	-	1210case	1	≦5	C1210C106M4PAC
	6.3V	47	0.002Ω	-	3225mm	1	≦5	C1210C476K9PAC
Murata, Ceramic X5R(SMD)	6.3V	100	0.002Ω	-	1210case	1[1]	≦3	GRM32ER60J107M
	6.3V	47	-	-	3225mm	1[1]	≦5	GRM32ER60J476M
	16V	22	-	-	-	1[1]	≦5	GRM32ER61C226K
	16V	10	-	-	-	1[1]	≦5	GRM32DR61C106K
TDK, Ceramic X5R(SMD)	6.3V	100	0.002Ω	-	1210case	1[1]	≦3	C3225X5R0J107MT
	6.3V	47	-	-	3225mm	1[1]	≦5	C3225X5R0J476MT
	16V	22	-	-	-	1[1]	≦5	C3225X5R1C226MT
	16V	10	-	-	-	1[1]	≦5	C3225X5R1C106MT

[1] A ceramic capacitor may be used to compliment electrolytic types at the input to further reduce high-frequency ripple current.

⚠ **Note:**

1. This datasheet is downloaded from the website of Murata Manufacturing co., ltd. Therefore, it's specifications are subject to change or our products in it may be discontinued without advance notice. Please check with our sales representatives or product engineers before ordering.
2. This datasheet has only typical specifications because there is no space for detailed specifications. Therefore, please approve our product specifications or transact the approval sheet for product specifications before ordering.

MPDTH03060W & MPDTH05060W

Adjustment of the Output Voltage of the MPDTH03060W & MPDTH05060W Wide-Output Adjust Power Modules

The *Vo Adjust* control (pin 4) sets the output voltage to a value higher than 0.8 V. The adjustment range of the MPDTH03060W (3.3-V input) is from 0.8 V to 2.5 V¹, and the MPDTH05060W (5-V input) from 0.8 V to 3.6 V. The adjustment method requires the addition of a single external resistor, *Rset*, that must be connected directly between the *Vo Adjust* and *GND* pins. Table 2-1 shows the preferred value of the external resistor for a number of standard voltages, along with the actual output voltage that this resistance value provides.

For other output voltages the value of the required resistor can either be calculated using the following formula, or simply selected from the range of values given in Table 2-2.

Figure 2-1 shows the placement of the required resistor.

$$R_{set} = 10 \text{ k}\Omega \cdot \frac{0.8\text{V}}{V_{out}-0.8\text{V}} - 2.49 \text{ k}\Omega$$

Table 2-1: Preferred Values of *Rset* for Standard Output Voltages

Vout(Standard)	Rset(Pref'd Value)	Vout(Actual)
3.3V(1)	698Ω	3.309V
2.5V	2.21kΩ	2.502V
2.0V	4.12kΩ	2.010V
1.8V	5.49kΩ	1.803V
1.5V	8.87kΩ	1.504V
1.2V	17.4kΩ	1.202V
1.0V	36.5kΩ	1.005V
0.8V	Open	0.8V

Figure 2-1: *Vo Adjust* Resistor Placement

Table 2-2: Output Voltage Set-Point Resistor Values

Vo Req'd	Rset	Vo Req'd	Rset
0.800	Open	2.00	4.18 kΩ
0.825	318 kΩ	2.05	3.91 kΩ
0.850	158 kΩ	2.10	3.66 kΩ
0.875	104 kΩ	2.15	3.44 kΩ
0.900	77.5 kΩ	2.20	3.22 kΩ
0.925	61.5 kΩ	2.25	3.03 kΩ
0.950	50.8 kΩ	2.30	2.84 kΩ
0.975	43.2 kΩ	2.35	2.67 kΩ
1.000	37.5 kΩ	2.40	2.51 kΩ
1.025	33.1 kΩ	2.45	2.36 kΩ
1.050	29.5 kΩ	2.50	2.22 kΩ
1.075	26.6 kΩ	2.55	2.08 kΩ
1.100	24.2 kΩ	2.60	1.95 kΩ
1.125	22.1 kΩ	2.65	1.83 kΩ
1.150	20.4 kΩ	2.70	1.72 kΩ
1.175	18.8 kΩ	2.75	1.61 kΩ
1.200	17.5 kΩ	2.80	1.51 kΩ
1.225	16.3 kΩ	2.85	1.41 kΩ
1.250	15.3 kΩ	2.90	1.32 kΩ
1.275	14.4 kΩ	2.95	1.23 kΩ
1.300	13.5 kΩ	3.00	1.15 kΩ
1.325	12.7 kΩ	3.05	1.07 kΩ
1.350	12.1 kΩ	3.10	988 Ω
1.375	11.4 kΩ	3.15	914 Ω
1.400	10.8 kΩ	3.20	843 Ω
1.425	10.3 kΩ	3.25	775 Ω
1.450	9.82 kΩ	3.30	710 Ω
1.475	9.36 kΩ	3.35	647 Ω
1.50	8.94 kΩ	3.40	587 Ω
1.55	8.18 kΩ	3.45	529 Ω
1.60	7.51 kΩ	3.50	473 Ω
1.65	6.92 kΩ	3.55	419 Ω
1.70	6.40 kΩ	3.60	367 Ω
1.75	5.93 kΩ		
1.80	5.51 kΩ		
1.85	5.13 kΩ		
1.90	4.78 kΩ		
1.95	4.47 kΩ		

Notes:

1. Modules that operate from a 3.3-V input bus should not be adjusted higher than 2.5 V.
2. Use a 0.1 W resistor. The tolerance should be 1 %, with temperature stability of 100 ppm/°C (or better). Place the resistor as close to the regulator as possible. Connect the resistor directly between pins 4 and 7 using dedicated PCB traces.
3. Never connect capacitors from *Vo Adjust* to either *GND* or *Vout*. Any capacitance added to the *Vo Adjust* pin will affect the stability of the regulator.

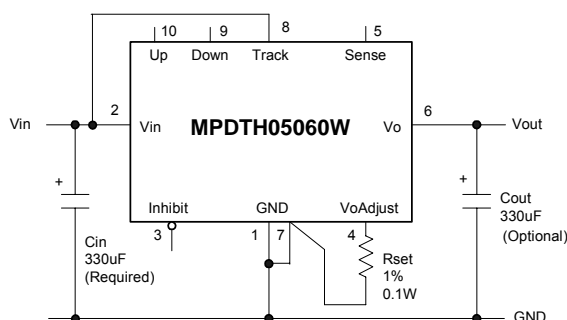
⚠ Note:

1. This datasheet is downloaded from the website of Murata Manufacturing co., ltd. Therefore, it's specifications are subject to change or our products in it may be discontinued without advance notice. Please check with our sales representatives or product engineers before ordering.
2. This datasheet has only typical specifications because there is no space for detailed specifications. Therefore, please approve our product specifications or transact the approval sheet for product specifications before ordering.

MPDTH03060W & MPDTH05060W

Features of the MPDTH Series of Non-Isolated Wide Output Adjust Power Modules

POLA™ Compatibility

The MPDTH family of non-isolated, wide-output adjust power modules from Murata Manufacturing are optimized for applications that require a flexible and high performance module that is small in size. Each of these products is POLA™ compatible. POLA compatible products are produced by a number of manufacturers, and offer customers advanced and non-isolated modules with the same footprint and form factor. POLA parts are also assured to be interoperable, thereby providing customers with true second-source availability.

From the basic “Just Plug it In” functionality of the 6-A modules to the 30-A rated feature-rich MPDTHxx030, these products were designed to be very flexible, and simple to use. The features vary with each product. Table 3-1 provides a quick reference to the features by product series and input bus voltage.

Table 3-1: Operating Features by Series and Input Bus Voltage

Series	Input Bus	Output	Adjust(Trim)	On/Off Inhibit	Over-Current	Pre-Bias Startup	Auto-Track™	Margin Up/Down	Output Sense	Thermal Shutdown
MPDTHxx050	3.3V	6A	o	o	o	o	o			
	5V	6A	o	o	o	o	o			
	12V	6A	o	o	o	o	o			
MPDTHxx060	3.3V/5V	10A	o	o	o	o	o	o	o	
	12V	8A	o	o	o	o	o	o	o	
MPDTHxx010	3.3V/5V	15A	o	o	o	o	o	o	o	
	12V	12A	o	o	o	o	o	o	o	
MPDTHxx020	3.3V/5V	22A	o	o	o	o	o	o	o	
	12V	18A	o	o	o	o	o	o	o	
MPDTHxx030	3.3V/5V	30A	o	o	o	o	o	o	o	
	12V	26A	o	o	o	o	o	o	o	

For simple point-of-use applications, the MPDTHxx050 provides operating features such as an on/off inhibit, output voltage trim, pre-bias startup, and over-current protection. The MPDTHxx060 (10 A/8A), and MPDTHxx010 (15/12 A) include an output voltage sense, and margin up/down controls. Then the higher output current MPDTHxx020 and MPDTHxx030 products incorporate over-temperature shutdown protection.

All of the products referenced in Table 3-1 include Auto-Track™. This feature was specifically designed to simplify the task of sequencing the supply voltages in a power system. This and other features are described in the following sections.

⚠ Note:

1. This datasheet is downloaded from the website of Murata Manufacturing co., ltd. Therefore, it's specifications are subject to change or our products in it may be discontinued without advance notice. Please check with our sales representatives or product engineers before ordering.
2. This datasheet has only typical specifications because there is no space for detailed specifications. Therefore, please approve our product specifications or transact the approval sheet for product specifications before ordering.

Soft-Start Power Up

The Auto-Track feature allows the power-up of multiple modules to be directly controlled from their *Track* pin.

However in a stand-alone configuration, or when the Auto-Track feature is not being used, the *Track* pin should be directly connected to the input voltage, V_{in} (see Figure 3-1).

Figure 3-1

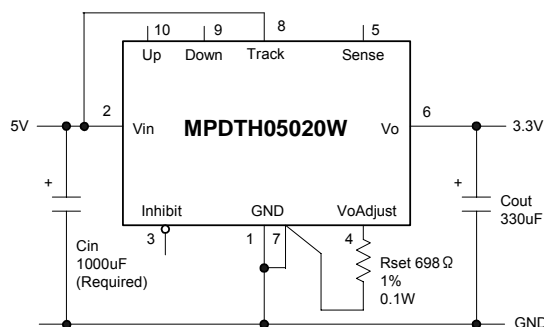

When the *Track* pin is connected to the input voltage the Auto-Track function is permanently disengaged. This allows the module to power up entirely under the control of its internal soft-start circuitry. When power up is under soft-start control, the output voltage rises to the set-point at a quicker and more linear rate.

Figure 3-2

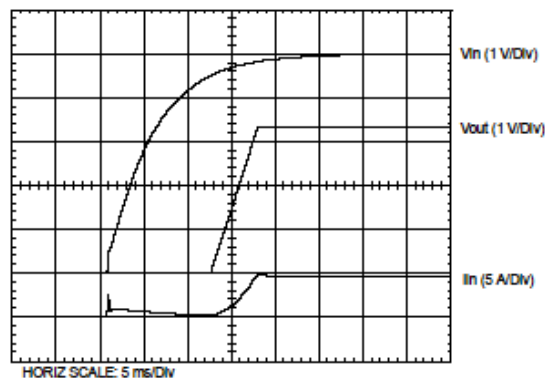

MPDTH03060W & MPDTH05060W

From the moment a valid input voltage is applied, the soft-start control introduces a short time delay (typically 5 ms-10 ms) before allowing the output voltage to rise. The output then progressively rises to the module's setpoint voltage. Figure 3-2 shows the soft-start power-up characteristic of the 22-A output product (MPDTH05020W), operating from a 5-V input bus and configured for a 3.3-V output. The waveforms were measured with a 5-A resistive load, with Auto-Track disabled. The initial rise in input current when the input voltage first starts to rise is the charge current drawn by the input capacitors. Power-up is completed within 15 ms.

Over-Current Protection

For protection against load faults, all modules incorporate output over-current protection. Applying a load that exceeds the regulator's over-current threshold will cause the regulated output to shutdown. Following shutdown, a module will periodically attempt to recover by initiating a soft-start power-up. This is described as a "hiccup" mode of operation, whereby the module continues in a cycle of successive shutdown and power up until the load fault is removed. During this period, the average current flowing into the fault is significantly reduced. Once the fault is removed, the module automatically recovers and returns to normal operation.

Over-Temperature Protection

The MPDTHxx020 and MPDTHxx030 series of products have over-temperature protection. These products have an on-board temperature sensor that protects the module's internal circuitry against excessively high temperatures. A rise of the internal temperature may be the result of a drop in airflow, or a high ambient temperature. If the internal temperature exceeds the OTP threshold, the module's *Inhibit* control is automatically pulled low. This turns off the output. The output voltage will drop as the external output capacitors are discharged by the load circuit. The recovery is automatic, and begins with a soft-start power up. It occurs when the sensed temperature decreases by about 10 °C below the trip point.

Note: The over-temperature protection is a last resort mechanism to prevent thermal stress to the regulator. Operation at or close to the thermal shutdown temperature is not recommended and will reduce the long-term reliability of the module. Always operate the regulator within the specified Safe Operating Area (SOA) limits for the worst-case conditions of ambient temperature and airflow.

Output On/Off Inhibit

For applications requiring output voltage on/off control, each series of the MPDTH family incorporates an output *Inhibit* control pin. The inhibit feature can be used wherever there is a requirement for the output voltage from the regulator to be turned off.

The power modules function normally when the *Inhibit* pin is left open-circuit, providing a regulated output whenever a valid source voltage is connected to *Vin* with respect to *GND*.

Figure 3-3 shows the typical application of the inhibit function. Note the discrete transistor (Q1). The *Inhibit* control has its own internal pull-up to *Vin* potential. The input is not compatible with TTL logic devices. An open collector (or open-drain) discrete transistor is recommended for control.

Figure 3-3

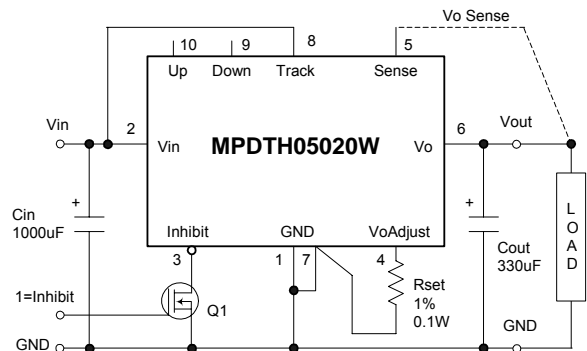

Turning Q1 on applies a low voltage to the *Inhibit* control and disables the output of the module. If Q1 is then turned off, the module will execute a soft-start power-up. A regulated output voltage is produced within 20 msec. Figure 3-4 shows the typical rise in both the output voltage and input current, following the turn-off of Q1. The turn off of Q1 corresponds to the rise in the waveform, Q1 Vds. The waveforms is measured with a 5-A load.

Figure 3-4

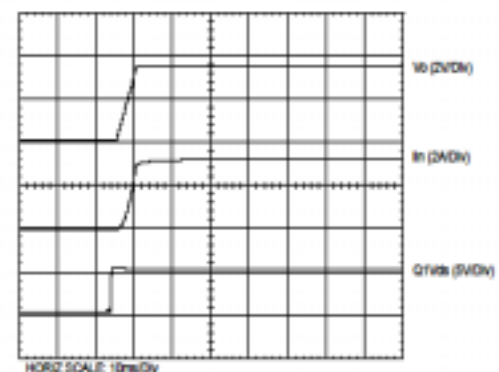

⚠ Note:

1. This datasheet is downloaded from the website of Murata Manufacturing co., ltd. Therefore, it's specifications are subject to change or our products in it may be discontinued without advance notice. Please check with our sales representatives or product engineers before ordering.
2. This datasheet has only typical specifications because there is no space for detailed specifications. Therefore, please approve our product specifications or transact the approval sheet for product specifications before ordering.

MPDTH03060W & MPDTH05060W

Auto-Track™ Function

The Auto-Track function is unique to the MPDTH family, and is available with the all POLA-compatible products. Auto-Track was designed to simplify the amount of circuitry required to make the output voltage from each module power up and power down in sequence. The sequencing of two or more supply voltages during power up is a common requirement for complex mixed-signal applications, that use dual-voltage VLSI ICs such as DSPs, micro-processors, and ASICs.

How Auto-Track Works

Auto-Track works by forcing the module's output voltage to follow a voltage presented at the *Track* control pin. This control range is limited between 0 V and the module's set-point voltage. Once the track-pin voltage is raised above the set-point voltage, the module's output remains at its set-point 1. For example, if the Track pin of a 2.5-V regulator is at 1 V, the regulated output will be 1 V. But if the voltage at the Track pin rises to 3 V, the regulated output will not go higher than 2.5 V.

When under track control, the regulated output from the module follows the voltage at its Track pin on a volt-for-volt basis. By connecting the Track pin of a number of these modules together, the output voltages will follow a common signal during power up and power down.

The control signal can be an externally generated master ramp waveform, or the output voltage from another power supply circuit 3. For convenience the Track control incorporates an internal RC charge circuit. This operates off the module's input voltage to provide a suitable rising voltage ramp waveform.

Typical Application

The basic implementation of Auto-Track allows for simultaneous voltage sequencing of a number of Auto-Track compliant modules. Connecting the Track control pins of two or more modules forces the Track control of all modules to follow the same collective RC ramp waveform, and allows them to be controlled through a single transistor or switch; Q1 in Figure 3-5.

To initiate a power-up sequence the Track control must be pulled first to ground potential. This should be done at or before input power is applied to the modules, and then held for at least 10 ms thereafter. This brief period gives the modules time to complete their internal soft-start initialization, which enables them to produce an output voltage.

Applying a logic-level high signal to the circuit's On/Off Control turns Q1 on and applies a ground signal to the Track control. After completing their internal soft-start initialization, the output of all modules will remain at zero volts while Q1 is on. 10 ms after a valid input voltage has been applied to all modules, Q1 can be turned off. This allows the track control voltage to automatically rise toward the modules' input voltage. During this period the output voltage of each module will rise in unison with other modules, to its respective set-point voltage.

Figure 3-6 shows the output voltage waveforms from the circuit of Figure 3-5 after the On/Off Control is set from a high to a low-level voltage. The waveforms, Vo1 and Vo2 represent the output voltages from the two power modules, U1 (3.3 V) and U2 (1.8 V) respectively. Vo1 and Vo2 are shown rising together to produce the desired simultaneous power up characteristic.

The same circuit also provides a power down sequence. Power down is the reverse of power up, and is accomplished by lowering the track control voltage back to zero volts. The important constraint is that a valid input voltage must be maintained until the power down is complete. It also requires that Q1 be turned off relatively slowly. This is so that the Track control voltage does not fall faster than Auto-Track's slew rate capability, which is 1 V/ms. The components R1 and C1 in Figure 3-5 limit the rate at which Q1 can pull down the Track control voltage. The values of 100 k-ohm and 0.1µF correlate to a decay rate of about 0.17 V/ms.

The power down sequence is initiated with a low-to-high transition at the On/Off Control input to the circuit.

Figure 3-7 shows the power down waveforms. As the Track control voltage falls below the nominal set-point voltage of each power module, then its output voltage decays with all the other modules under Auto-Track control.

Notes on Use of Auto-Track™

1. The Track pin voltage must be allowed to rise above the module's set-point voltage before the module can regulate at its adjusted set-point voltage.
2. The Auto-Track function will track almost any voltage ramp during power up, and is compatible with ramp speed of up to 1 V/ms.
3. The absolute maximum voltage that may be applied to the Track pin is V_{in} .
4. The module will not follow a voltage at its Track control input until it has completed its soft-start initialization. This takes about 10 ms from the time that the module has sensed that a valid voltage has been applied at its input. During this period, it is recommended that the Track pin be held at ground potential.
5. The module is capable of both sinking and sourcing current when following a voltage at its Track pin. Therefore startup into an output prebias is not supported during Auto-Track control.
Note: A pre-bias holdoff is not necessary when all supply voltages rise simultaneously under the control of Auto-Track.
6. The Auto-Track function can be disabled by connecting the Track pin to the input voltage (V_{in}). With Auto-Track disabled, the output voltage will rise at a quicker and more linear rate after input power is applied.

NOTE.

1. This datasheet is downloaded from the website of Murata Manufacturing co., ltd. Therefore, it's specifications are subject to change or our products in it may be discontinued without advance notice. Please check with our sales representatives or product engineers before ordering.
2. This datasheet has only typical specifications because there is no space for detailed specifications. Therefore, please approve our product specifications or transact the approval sheet for product specifications before ordering.

MPDTH03060W & MPDTH05060W

Figure 3-5; Sequenced Power Up & Power Down Using Auto-Track

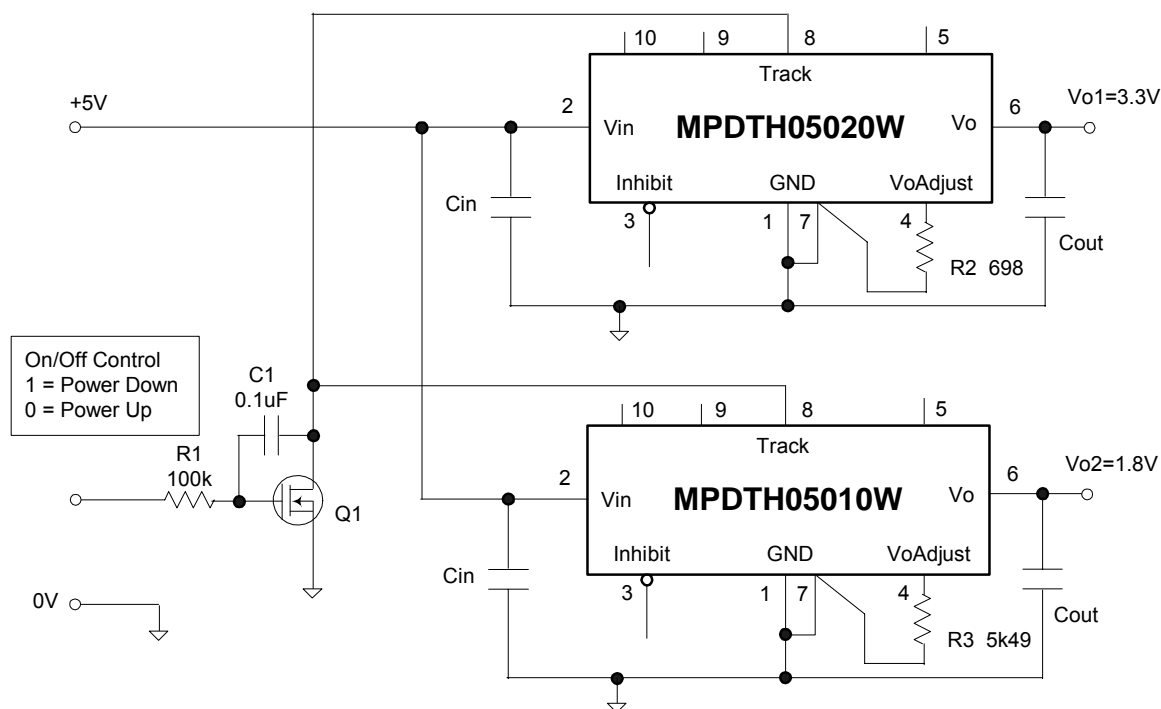

Figure 3-6; Simultaneous Power Up with Auto-Track Control

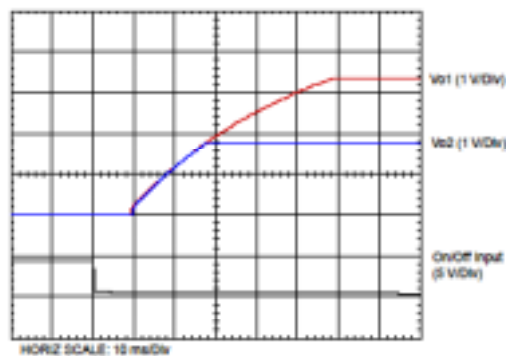
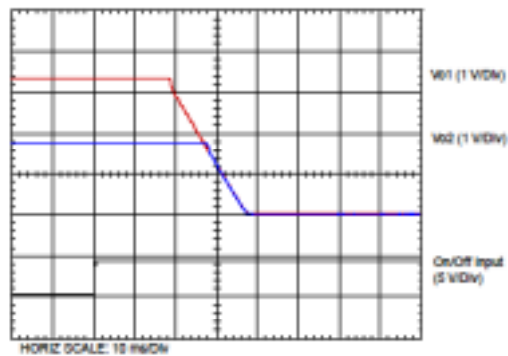

Figure 3-7; Simultaneous Power Down with Auto-Track Control



⚠ Note:

1. This datasheet is downloaded from the website of Murata Manufacturing co., ltd. Therefore, it's specifications are subject to change or our products in it may be discontinued without advance notice. Please check with our sales representatives or product engineers before ordering.
2. This datasheet has only typical specifications because there is no space for detailed specifications. Therefore, please approve our product specifications or transact the approval sheet for product specifications before ordering.

MPDTH03060W & MPDTH05060W

Margin Up/Down Controls

The MPDTHxx060, MPDTHxx010, MPDTHxx020, and MPDTHxx030 products incorporate *Margin Up* and *Margin Down* control inputs. These controls allow the output voltage to be momentarily adjusted $\pm 5\%$, either up or down, by a nominal 5%. This provides a convenient method for dynamic testing of the operation of the load circuit over its supply margin or range. It can also be used to verify the function of supply voltage supervisors. The $\pm 5\%$ change is applied to the adjusted output voltage, as set by the external resistor, R_{set} at the $V_o Adjust$ pin.

The 5% adjustment is made by pulling the appropriate margin control input directly to the GND terminal. A low-leakage open-drain device, such as an n-channel MOSFET or p-channel JFET is recommended for this purpose. Adjustments of less than 5% can also be accommodated by adding series resistors to the control inputs. The value of the resistor can be selected from Table 3-2, or calculated using the following formula.

Up/Down Adjust Resistance Calculation

To reduce the margin adjustment to a value less than 5%, series resistors are required (See R_D and R_U in Figure 3-8). For the same amount of adjustment, the resistor value calculated for R_U and R_D will be the same. The formula is as follows.

$$R_U \text{ or } R_D = \frac{499}{\Delta\%} - 99.8 \quad \text{k}\Omega$$

Where $\Delta\%$ = The desired amount of margin adjust in percent.

Notes:

1. The *Margin Up** and *Margin Dn** controls were not intended to be activated simultaneously. If their effects on the output voltage may not be completely canceled, resulting in the possibility of a slightly higher error in the output voltage set point.
2. The ground reference should be a direct connection to the module GND at pin 7 (pin 1 for the MPDTHxx050). This will produce a more accurate adjustment at the load circuit terminals. The transistors Q1 and Q2 should be located close to the regulator.
3. The Margin Up and Margin Dn control inputs are not compatible with devices that source voltage. This includes TTL logic. These are analog inputs and should only be controlled by a true open-drain device (preferably a discrete MOSFET transistor). The selected device should have low off-state leakage current. Each input sources $8\mu A$ when grounded, and has an open-circuit voltage of 0.8 V.

Table 3-2: Margin Up/Down Resistor Values

%Adjust	R_U / R_D
5	0.0k Ω
4	24.9k Ω
3	66.5k Ω
2	150k Ω
1	397k Ω

Figure 3-8: Margin Up/Down Application Schematic

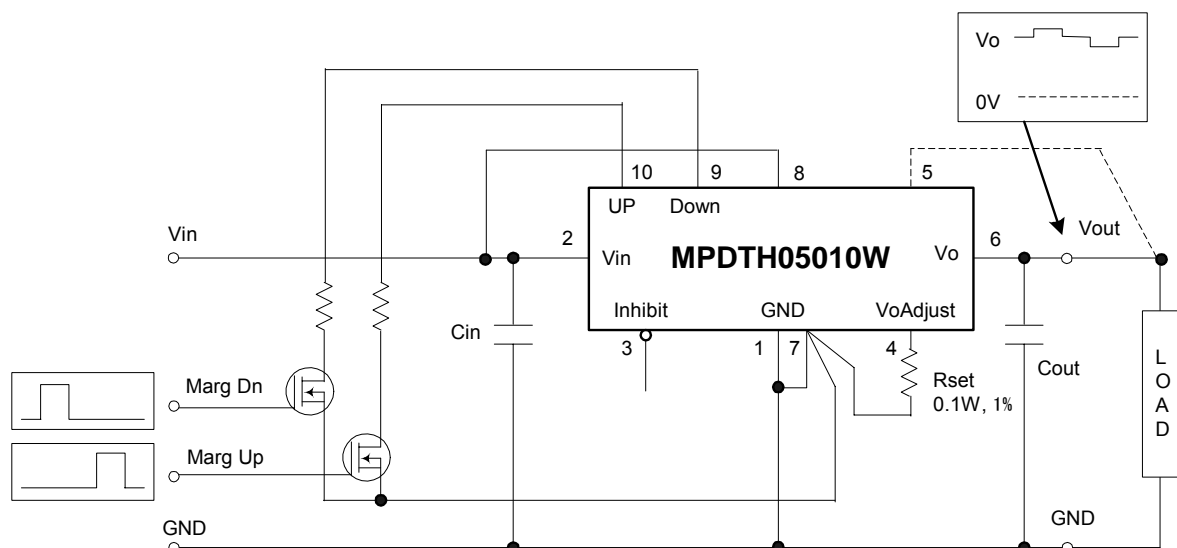

Note:

1. This datasheet is downloaded from the website of Murata Manufacturing co., ltd. Therefore, it's specifications are subject to change or our products in it may be discontinued without advance notice. Please check with our sales representatives or product engineers before ordering.
2. This datasheet has only typical specifications because there is no space for detailed specifications. Therefore, please approve our product specifications or transact the approval sheet for product specifications before ordering.

MPDTH03060W & MPDTH05060W

Pre-Bias Startup Capability

A pre-bias startup condition occurs as a result of an external voltage being present at the output of a power module prior to its output becoming active. This often occurs in complex digital systems when current from another power source is backed through a dual-supply logic component, such as an FPGA or ASIC. Another path might be via clamp diodes as part of a dual-supply power-up sequencing arrangement. A prebias can cause problems with power modules that incorporate synchronous rectifiers. This is because under most operating conditions, these types of modules can sink as well as source output current.

The MPDTH family of power modules incorporate synchronous rectifiers, but will not sink current during startup 1, or whenever the *Inhibit* pin is held low. However, to ensure satisfactory operation of this function, certain conditions must be maintained. 2 Figure 3-9 shows an application demonstrating the pre-bias startup capability. The start-up waveforms are shown in Figure 3-10. Note that the output current from the MPDTH03010W (I_o) shows negligible current until its output voltage rises above that backed through diodes D1 and D2.

*Note: The pre-bias start-up feature is not compatible with Auto-Track. When the module is under Auto-Track control, it will sink current if the output voltage is below that of a back-feeding source. To ensure a pre-bias hold-off one of two approaches must be followed when input power is applied to the module. The Auto-Track function must either be disabled³, or the module's output be held off (for at least 50 ms) using the *Inhibit* pin. Either approach ensures that the *Track* pin voltage is above the set-point voltage at start up.*

Notes

1. Startup includes the short delay (approx. 10 ms) prior to the output voltage rising, followed by the rise of the output voltage under the module's internal soft-start control. Startup is completed when the output voltage has risen to either the set-point voltage or the voltage at the *Track* pin, whichever is lowest.
2. To ensure that the regulator does not sink current when power is first applied (even with a ground signal applied to the *Inhibit* control pin), the input voltage must always be greater than the output voltage throughout the power-up and power-down sequence.
3. The Auto-Track function can be disabled at power up by applying immediately a voltage to the module's *Track* pin that is greater than its set-point voltage. This can be easily accomplished by connecting the *Track* pin to V_{in} .

Figure 3-10: Pre-Bias Startup Waveforms

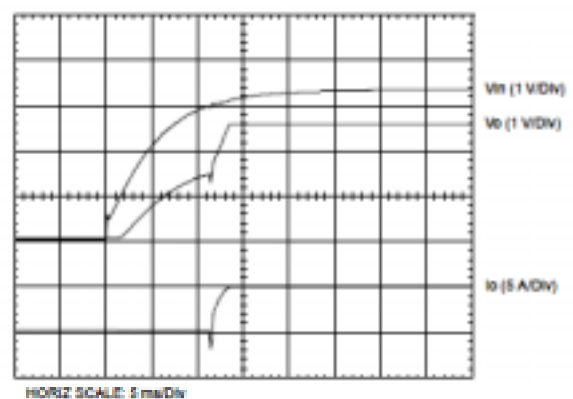
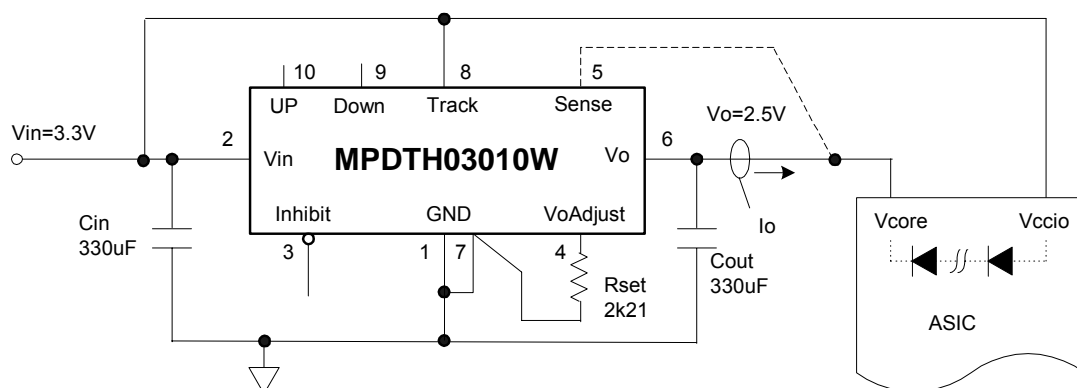

Figure 3-9: Application Circuit Demonstrating Pre-Bias Startup



⚠ Note:

1. This datasheet is downloaded from the website of Murata Manufacturing co., ltd. Therefore, it's specifications are subject to change or our products in it may be discontinued without advance notice. Please check with our sales representatives or product engineers before ordering.
2. This datasheet has only typical specifications because there is no space for detailed specifications. Therefore, please approve our product specifications or transact the approval sheet for product specifications before ordering.

MPDTH03060W & MPDTH05060W

Remote Sense

Products with this feature incorporate an output voltage sense pin, *Vo Sense*. A remote sense improves the load regulation performance of the module by allowing it to compensate for any 'IR' voltage drop between itself and the load. An IR drop is caused by the high output current flowing through the small amount of pin and trace resistance. To use this feature simply connect the *Vo Sense* pin to the *Vout* node, close to the load circuit (see data sheet standard application). If not used, the *Vo Sense* pin can be left open-circuit. An internal low-value resistor (15-Ω or less) is connected between the *Vo Sense* and *Vout*. This ensures the output voltage remains in regulation.

With the sense pin connected, the difference between the voltage measured directly between the *Vout* and *GND* pins, and that measured from *Vo Sense* to *GND*, is the amount of IR drop being compensated by the regulator. This should be limited to a maximum of 0.3 V.

Note: The remote sense feature is not designed to compensate for the forward drop of non-linear or frequency dependent components that may be placed in series with the converter output. Examples include OR-ing diodes, filter inductors, ferrite beads, and fuses. When these components are enclosed by the remote sense connection they are effectively placed inside the regulation control loop, which can adversely affect the stability of the regulator.

⚠ Note:

1. This datasheet is downloaded from the website of Murata Manufacturing co., ltd. Therefore, it's specifications are subject to change or our products in it may be discontinued without advance notice. Please check with our sales representatives or product engineers before ordering.
2. This datasheet has only typical specifications because there is no space for detailed specifications. Therefore, please approve our product specifications or transact the approval sheet for product specifications before ordering.

MPDTH03060W & MPDTH05060W

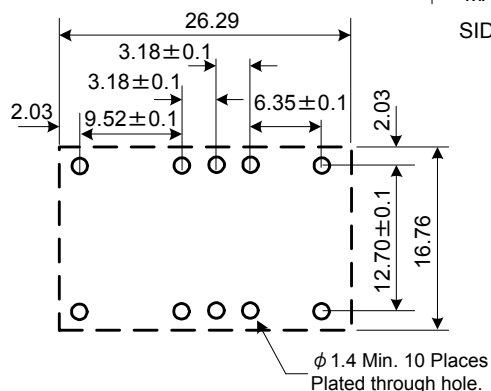
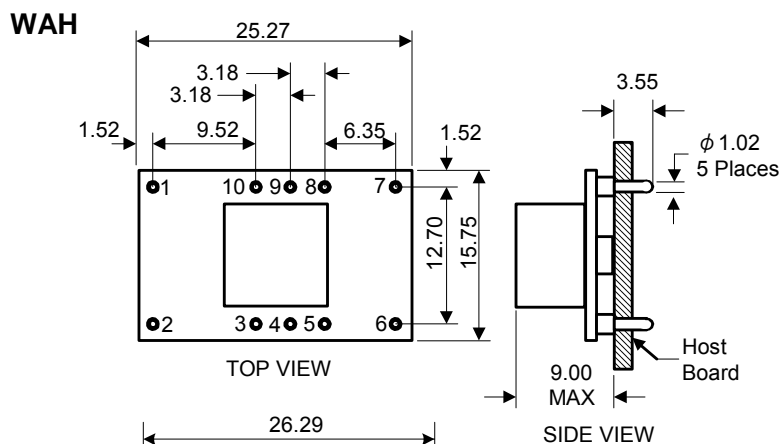
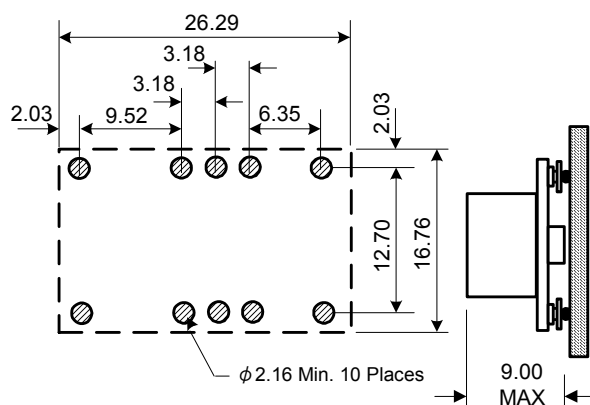
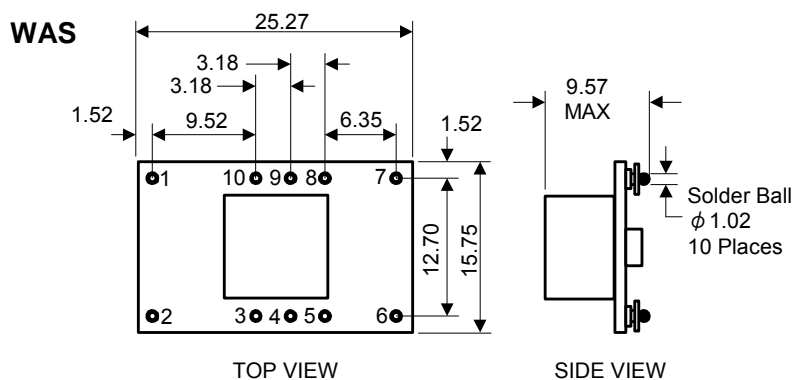

⚠ **Note:**

1. This datasheet is downloaded from the website of Murata Manufacturing co., ltd. Therefore, it's specifications are subject to change or our products in it may be discontinued without advance notice. Please check with our sales representatives or product engineers before ordering.
2. This datasheet has only typical specifications because there is no space for detailed specifications. Therefore, please approve our product specifications or transact the approval sheet for product specifications before ordering.

IMPORTANT NOTICE

Murata Manufacturing Co., Ltd. and its subsidiaries (Murata) reserve the right to make corrections, modifications, enhancements, improvements, and other changes to its products and services at any time and to discontinue any product or service without notice. Customers should obtain the latest relevant information before placing orders and should verify that such information is current and complete. All products are sold subject to Murata's terms and conditions of sale supplied at the time of order acknowledgment.

Murata warrants performance of its hardware products to the specifications applicable at the time of sale in accordance with Murata's standard warranty. Testing and other quality control techniques are used to the extent Murata deems necessary to support this warranty. Except where mandated by government requirements, testing of all parameters of each product is not necessarily performed.

Murata assumes no liability for applications assistance or customer product design. Customers are responsible for their products and applications using Murata components. To minimize the risks associated with customer products and applications, customers should provide adequate design and operating safeguards.

Murata does not warrant or represent that any license, either express or implied, is granted under any Murata patent right, copyright, or other Murata intellectual property right relating to any combination, machine, or process in which Murata products or services are used. Information published by Murata regarding third-party products or services does not constitute a license from Murata to use such products or services or a warranty or endorsement thereof. Use of such information may require a license from a third party under the patents or other intellectual property of the third party, or a license from Murata under the patents or other intellectual property of Murata.

Reproduction of information in Murata data books or data sheets is permissible only if reproduction is without alteration and is accompanied by all associated warranties, conditions, limitations, and notices. Reproduction of this information with alteration is an unfair and deceptive business practice. Murata is not responsible or liable for such altered documentation.

Resale of Murata products or services with statements different from or beyond the parameters stated by Murata for that product or service voids all express and any implied warranties for the associated Murata product or service and is an unfair and deceptive business practice. MURATA is not responsible or liable for any such statements.

Copyright 2005, Murata Manufacturing Co., Ltd.

⚠ Note:

1. This datasheet is downloaded from the website of Murata Manufacturing co., ltd. Therefore, it's specifications are subject to change or our products in it may be discontinued without advance notice. Please check with our sales representatives or product engineers before ordering.
2. This datasheet has only typical specifications because there is no space for detailed specifications. Therefore, please approve our product specifications or transact the approval sheet for product specifications before ordering.