

DC-DC Converter Application Manual

MPDTH04040W**

60-A, 3.3 -V to 5-V Input Non-Isolated Wide-Output Adjust Power Module



Features

- 60-A Output Current
- 3.3-V to 5V Input Voltage
- Wide-Output Voltage Adjust (0.8 V to 2.5 V)
- Efficiencies up to 93 %
- On/Off Inhibit
- Differential Output Sense
- Output Overcurrent Protection (Non-latching, Auto-Reset)
- Overtemperature Protection
- Auto-Track™ Sequencing
- Start Up Into Output Prebias
- Margin Up/Down Controls
- Operating Temp: -40 to +85°C
- Multi-Phase, Switch-Mode Topology
- Programmable Undervoltage Lockout (UVLO)
- Safety Agency Approvals : UL/cUL 60950, EN60950, VDE (Pending)

NOMINAL SIZE = 52 mm x 26.7 mm

Description

The MPDTH04040W is a high-performance 60-A rated, non-isolated, power module, which uses the latest multiphase switched-mode topology. This provides a small, ready-to-use module, that can power the most densely populated multiprocessor systems.

The MPDTH04040W operates over an input voltage range of 2.95 V to 5.5 V, and can be set to any output voltage over the range, 0.8 V to 2.5 V, using a single external resistor. The combination of a wide input voltage and wide-output adjust range allows the MPDTH04040W to be used in many of high-performance applications. These include advanced computing platforms and servers that utilize either a 3.3-V or 5-V distribution bus.

These modules incorporate a comprehensive list of features. They include an on/off inhibit and margin up/down controls. A differential remote output voltage sense ensures tight load regulation, and an output overcurrent and overtemperature shutdown protect against most load faults. A programmable undervoltage lockout allows the turn-on threshold to be customized.

The MPDTH04040W incorporates Auto-Track™. Auto-Track is a popular feature of the MPDTH family that allows the outputs of multiple modules to track a common voltage during power-up and power-down transitions. This greatly simplifies the sequencing of voltages for VLSI ICs that operate off multiple power rails. The double-sided surface mount construction has a low profile and compact footprint. It is available in both through-hole and surface-mount packages.

Pin Configuration

Pin	Function
1	GND
2	Vin
3	GND
4	Vin
5	GND
6	Vin
7	Inhibit
8	UVLO Prog
9	Vout
10	GND
11	+Sense
12	Vout
13	GND
14	-Sense
15	Vout
16	GND
17	Vo Adjust
18	Track
19	Margin Up
20	Margin Down

Standard Application

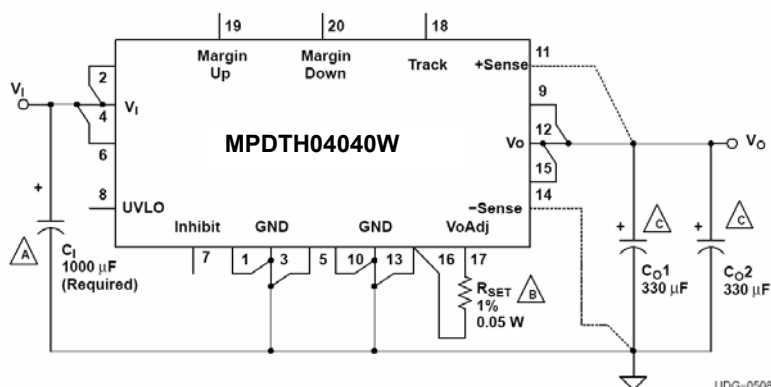

- A. For C_1 , a minimum of 1,000µF (or 2 x 470µF) of input capacitance is required for proper operation.
 B. R_{SET} is required to set the desired output voltage from the module higher than the minimum value.
 C. For C_{O1} and C_{O2} , a minimum of 660µF (or 2 x 330µF) of input capacitance is required load transient regulation.

Note:

1. This datasheet is downloaded from the website of Murata Manufacturing co., ltd. Therefore, it's specifications are subject to change or our products in it may be discontinued without advance notice. Please check with our sales representatives or product engineers before ordering.
2. This datasheet has only typical specifications because there is no space for detailed specifications. Therefore, please approve our product specifications or transact the approval sheet for product specifications before ordering.

Ordering Information

Output Voltage (MPDTH04040□xx)

Code	Voltage
W	0.8V-2.5V(Adjustable)

Package Options (MPDTH04040x□□)

Code	Description
AH	Horiz. T/H
AS	SMD(*1)

Notes (1) Pb free (Sn-Ag-Cu) pin solder material.

Pin Description

GND: This is the common ground connection for the VI and VO power connections. It is also the 0 Vdc reference for the control inputs.

Vin: The positive input voltage power node to the module, which is referenced to common GND.

Vout: The regulated positive power output with respect to the GND node.

Inhibit ⁽¹⁾: The Inhibit pin is an open-collector/drain negative logic input that is referenced to GND. Applying a lowlevel ground signal to this input disables the module's output and turns off the output voltage. When the Inhibit control is active, the input current drawn by the regulator is significantly reduced. If the Inhibit pin is left open-circuit, the module produces an output whenever a valid input source is applied.

Vo Adjust: A 1%, 0.05-W resistor must be connected between this pin and GND to set the output voltage higher than the minimum value. The set-point range for the output voltage is from 0.8 V to 2.5 V. The resistor required for a given output voltage may be calculated from the following formula. If left open circuit, the module output defaults to its lowest output voltage value. For further information on the adjustment and/or trimming of the output voltage, see the related Application Information section.

Note: The specification table gives the preferred resistor values for a number of standard output voltages.

+Sense: The sense inputs allow the regulation circuit to compensate for voltage drop between the module and the load. For optimal voltage accuracy, +Sense should be connected to VO. If it is left open, a low-value internal resistor ensures that the output remains in regulation.

-Sense: For optimal voltage accuracy, -Sense should be connected to the ground return at the load. If it is left open, a low-value internal resistor ensures that the output remains in regulation.

UVLO Prog: Connecting a resistor from this pin to signal ground allows the *on* threshold of the input undervoltage lockout (UVLO) to be adjusted higher than the default value. The hysteresis can also be independently reduced by connecting a second resistor from this pin to Vin. For further information, see the Application Information section.

Track: This is an analog control input that allows the output voltage to follow another voltage during power up and power down sequences. The pin is active from 0 V, up to the nominal set-point voltage. Within this range, the module output follows the voltage at the Track pin on a volt-for-volt basis. When the control voltage is raised above this range, the module regulates at its nominal output voltage. If unused, this input should be connected to Vin for a faster power up. For further information, see the Application Information section.

Margin Down ⁽¹⁾: When this input is asserted to GND, the output voltage is decreased by 5% from the nominal. The input requires an open-collector (open-drain) interface. It is not TTL compatible. A lower percent change can be accommodated with a series resistor. For further information, see the related Application Information section.

Margin Up ⁽¹⁾: When this input is asserted to GND, the output voltage is increased by 5%. The input requires an open collector (open-drain) interface. It is not TTL compatible. The percent change can be reduced with a series resistor. For further information, see the Application Information section.

(1) Denotes negative logic: Open = Normal operation
Ground = Function active

⚠ Note:

1. This datasheet is downloaded from the website of Murata Manufacturing co., ltd. Therefore, it's specifications are subject to change or our products in it may be discontinued without advance notice. Please check with our sales representatives or product engineers before ordering.
2. This datasheet has only typical specifications because there is no space for detailed specifications. Therefore, please approve our product specifications or transact the approval sheet for product specifications before ordering.

Environmental & Absolute Maximum Ratings (Voltages are with respect to GND)

Characteristics	Symbols	Conditions	Min	Typ	Max	Units
Track Input Voltage	V _{track}		-0.3	-	V _{in} +0.3	V
Operating Temperature Range	T _a	Over V _{in} Range	-40	-	85	°C
Storage Temperature	T _s	-	-40	-	125	°C
Solder Reflow Temperature	T _{reflow}	Surface temperature of module body or pins			245(j)	°C

Notes: (j) During reflow of SMD package version do not elevate peak temperature of the module, pins or internal components above the stated maximum.

Specifications (Unless otherwise stated, T_a =25 °C, V_{in} =5 V, V_{out} =2.5 V, C_{in} =1000μF, C_{out} =660μF, and I_o =I_{omax})

Characteristics	Symbols	Conditions	MPDTH12040W				
			Min	Typ	Max	Units	
Output Current	I _o	60 °C 200LFM airflow	0	-	60 (1)	A	
Input Voltage Range	V _{in}	Over I _o range	2.95(2)	-	5.5	V	
Set-Point Voltage Tolerance	V _{o tol}		-	-	±2(3)	%V _o	
Temperature Variation	ΔRegtemp	-40°C <T _a < +85 °C	-	±0.5	-	%V _o	
Line Regulation	ΔRegline	Over V _{in} range	-	±5	-	mV	
Load Regulation	ΔRegload	Over I _o range	-	±5	-	mV	
Total Output Variation	ΔRegtot	Includes set-point, line, load, -40 °C <T _a < +85 °C	-	-	±3(2)	%V _o	
Output adjust range	ΔV _{o,adj}	2.95 ≤V _{in} ≤4.5(3)	0.8	-	1.65	V	
		4.5 ≤V _{in} ≤5.5(3)	0.8	-	2.5		
Efficiency	η	V _{in} =5V, I _o =45A	RSET = 2.21kΩ V _o = 2.5 V	-	93	-	%
			RSET = 5.49 kΩ V _o = 1.8 V	-	90	-	
			RSET = 8.87 kΩ V _o = 1.5 V	-	88	-	
		V _{in} =3.3V, I _o =45A	RSET = 17.4kΩ V _o = 1.2 V	-	86	-	
			RSET =5.49 kΩ V _o = 1.8 V	-	92	-	
			RSET = 8.87 kΩ V _o = 1.5 V	-	91	-	
RSET = 36.5 kΩ V _o = 1 V	-	87	-				
Vo Ripple (peak-to-peak)	V _r	20 MHz bandwidth All voltages	-	15	-	mVpp	
Overcurrent threshold	I _{o trip}	Reset, followed by auto-recovery	-	90	-	A	
Transient Response	t _{tr}	1 A/us load step, 50 to 100 % I _{omax} C _{out} =660μF	Recovery Time	-	100	-	μS
	ΔV _{tr}		V _o over/undershoot	-	200	-	mV
Margin Up/Down Adjust	ΔV _{omargin}	From a given set point voltage	-	±5	-	%	
Margin Input Current	I _{IL margin}	Pin to GND	-	-8(4)	-	μA	
Track Input Current (pin 18)	I _{IL track}	Pin to GND	-	-	-0.11 (5)	mA	
Track Slew Rate Capability	dV/dt	V _{TRACK} - V _O ≤ 50 mV and V _{TRACK} < V _O (nom)	-	-	1	V/ms	
Undervoltage lockout	UVLO	Pin 8 open	On-threshold	-	2.6(6)	-	V
			Hysteresis	-	0.6(6)	-	
Inhibit Control (pin7)	V _{IH}	Referenced to GND	2.5	-	Open(5)	V	
Input High Voltage	V _{IH}		2.5	-	Open(5)	V	
Input Low Voltage	V _{IL}		-0.2	-	0.5	V	
Input Low Current	I _{ILinhibit}	Pin to GND	-	0.5	-	mA	
Input Standby Current	I _{lin inh}	Inhibit (pin 7) to GND	-	60	-	mA	
Switching Frequency	Frq	Over V _{in} and I _o ranges	675	825	975	kHz	
External Input Capacitance	C _{in}		940 (7)	-	-	μF	
External Output Capacitance	C _{out}	Capacitance value	non-ceramic	660 (8)	-	14000(9)	μF
			ceramic	-	-	400	
		Equivalent series resistance (non-ceramic)	2 (10)	-	-	mΩ	
MTBF	MTBF	Per Bellcore TR-332 50 % stress, T _a =40°C, ground benign	2.1	-	-	10 ⁶ Hrs	

Notes:(1) See SOA curves or consult factory for appropriate derating.

(2) The nominal input voltage must be at least 2 □ V_o. Output voltage regulation is guaranteed with an input voltage within ±10% from nominal 3.3 V or 5 V. For example, for V_i = 5 V and V_o = 2.5 V, the input can vary between 4.5 V and 5.5 V.

(3) The set-point voltage tolerance is affected by the tolerance of R_{SET}. The stated limit is unconditionally met if R_{SET} has a tolerance of 1% with 100 ppm/°C or better temperature stability.

(4) A small, low-leakage (<100 nA) MOSFET is recommended to control this pin. The open-circuit voltage is less than 1 Vdc.

(5) This control pin has an internal pull-up to V_i. If it is left open-circuit the module operates when input power is applied. A small, low-leakage (<100 nA) MOSFET or open-drain/collector voltage supervisor IC is recommended for control. Do not place an external pull-up on this pin. See the *Application Information* section for further guidance.

(6) These are the default voltages. They may be adjusted using the UVLO Prog control input. See the *Application Information* section for further guidance.

(7) A minimum capacitance of 940 μF is required at the input for proper operation. The capacitance must be rated for a minimum of 400 mArms of ripple current.

(8) A minimum value of output capacitance is required for proper operation. Adding additional capacitance at the load will further improve transient response.

(9) This is the calculated maximum. The minimum ESR requirement often results in a lower value. See the *Application Information* section for further guidance.

(10) This is the typical ESR for all the electrolytic (nonceramic) output capacitance. Use 4 mΩ as the minimum when using max-ESR values to calculate.

⚠ Note:

- This datasheet is downloaded from the website of Murata Manufacturing co., Ltd. Therefore, it's specifications are subject to change or our products in it may be discontinued without advance notice. Please check with our sales representatives or product engineers before ordering.
- This datasheet has only typical specifications because there is no space for detailed specifications. Therefore, please approve our product specifications or transact the approval sheet for product specifications before ordering.

Characteristic Data; $V_{in} = 3.3\text{ V}^{(1)(2)}$

Typical Characteristics

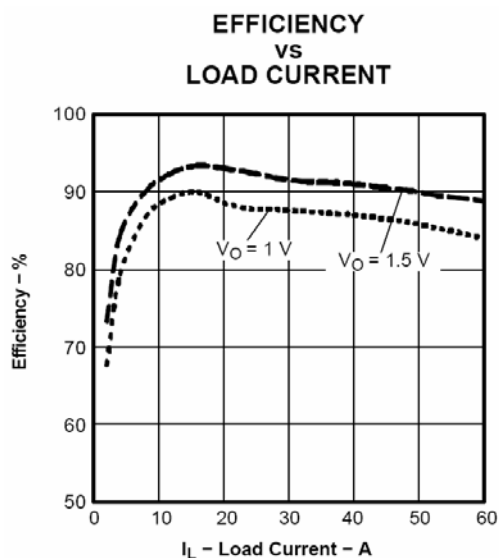

Figure 1

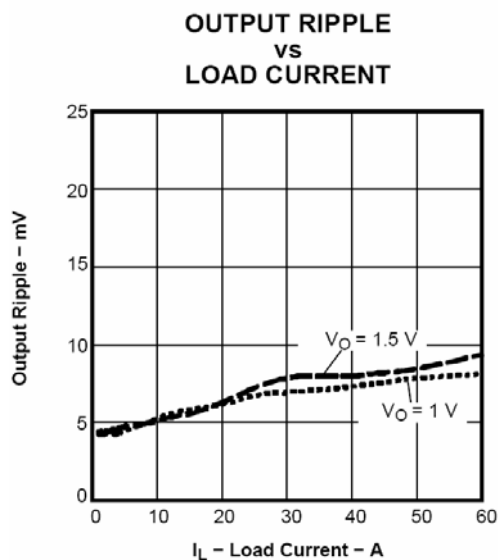

Figure 2

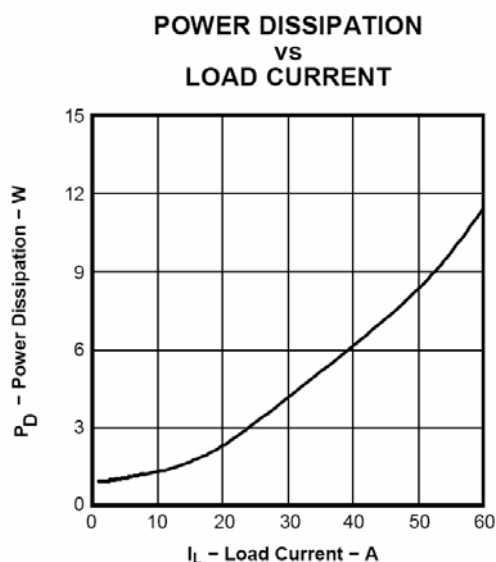

Figure 3

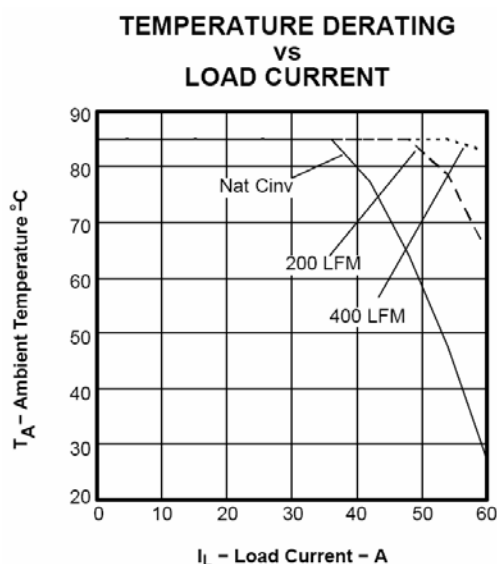

Figure 4

- (1) The electrical characteristic data has been developed from actual products tested at 25°C. This data is considered typical for the converter. Applies to [Figure 1](#), [Figure 2](#), and [Figure 3](#).
- (2) SOA curves represent the conditions at which internal components are at or below the manufacturer's maximum operating temperatures. Derating limits apply to modules soldered directly to a 4 inches x 4 inches double-sided PCB with 1 oz. copper. Applies to [Figure 4](#).

⚠ **Note:**

1. This datasheet is downloaded from the website of Murata Manufacturing co., Ltd. Therefore, it's specifications are subject to change or our products in it may be discontinued without advance notice. Please check with our sales representatives or product engineers before ordering.
2. This datasheet has only typical specifications because there is no space for detailed specifications. Therefore, please approve our product specifications or transact the approval sheet for product specifications before ordering.

Characteristic Data; $V_{in} = 5\text{ V}$ EFFICIENCY
VS
LOAD CURRENT

Figure 5

OUTPUT RIPPLE
VS
LOAD CURRENT

Figure 6

POWER DISSIPATION
VS
LOAD CURRENT

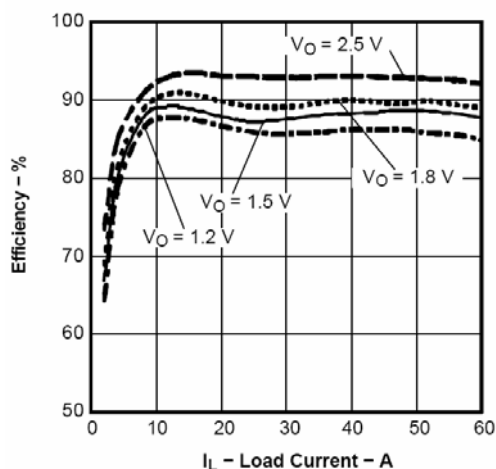
Figure 7

TEMPERATURE DERATING
VS
LOAD CURRENT

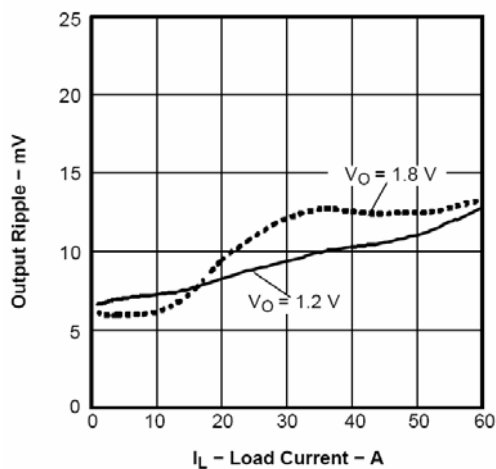
Figure 8

- (1) The electrical characteristic data has been developed from actual products tested at 25°C. This data is considered typical for the converter. Applies to Figure 5, Figure 6, and Figure 7.
- (2) SOA curves represent the conditions at which internal components are at or below the manufacturer's maximum operating temperatures. Derating limits apply to modules soldered directly to a 4 inches x 4 inches double-sided PCB with 1 oz. copper. Applies to Figure 8.

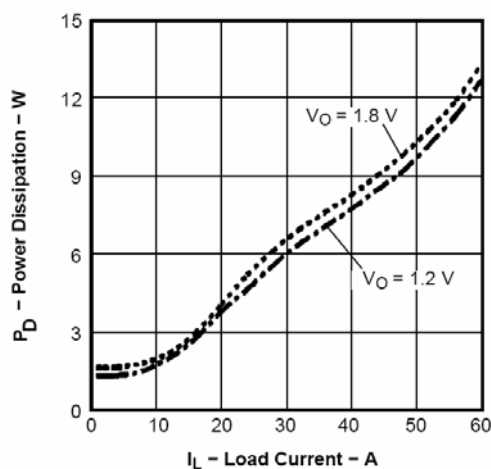
⚠ Note:

- This datasheet is downloaded from the website of Murata Manufacturing co., Ltd. Therefore, it's specifications are subject to change or our products in it may be discontinued without advance notice. Please check with our sales representatives or product engineers before ordering.
- This datasheet has only typical specifications because there is no space for detailed specifications. Therefore, please approve our product specifications or transact the approval sheet for product specifications before ordering.

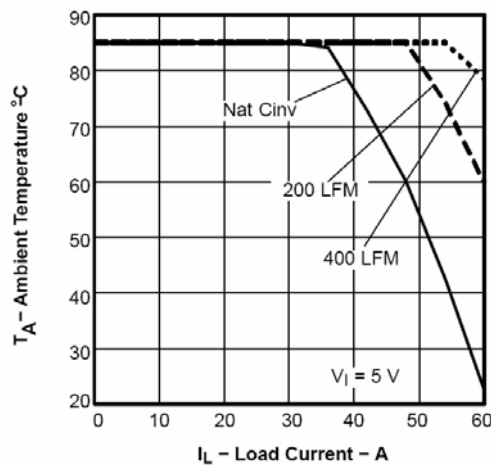
Capacitor Recommendations for the MPDTH04040W Power Modules

The MPDTH04040W uses state-of-the-art multi-phase power converter topology that employs multiple parallel switching and filter inductor paths between the input and output capacitors. The MPDTH04040W uses three switching paths. The three paths share the total load current, operate at the same frequency, and are evenly displaced in phase. With multiple switching paths the transient output current capability is significantly increased. This reduces the amount of external output capacitance required to support a load transient. The ripple current, as seen by the input and output capacitors, is reduced in magnitude and effectively tripled in frequency.

Input Capacitor

The improved transient response of a multi-phase converter places a bigger burden on the transient capability of the input source. The size and value of the input capacitor is therefore determined by this converter's transient performance capability. The minimum amount of input capacitance required is 940 μ F (2 x 470 μ F or 3 x 330 μ F), with an RMS ripple current rating of 400 mA. This minimum value assumes that the converter is supplied with a responsive, low-inductance input source. This source should have ample capacitive decoupling and be distributed the converter via PCB power and ground planes. For highperformance applications, or wherever the transient capability of the input source is limited, 2,200 μ F of input capacitance is recommended.

Ripple current and less than 100 m Ω equivalent series resistance (ESR) values are the major considerations, along with temperature, when designing with different types of capacitors. Unlike polymer tantalum, conventional tantalum capacitors have a recommended minimum voltage rating of 2 x (maximum dc voltage + ac ripple). This is standard practice to ensure reliability.

For improved ripple reduction on the input bus, ceramic capacitors may be used to complement electrolytic types and achieve the minimum required capacitance.

OUTPUT CAPACITORS RECOMMENDED

In order to respond with load transients (sudden changes in load current) the regulator requires external output capacitance. The minimum output capacitance is 660 μ F (2 x 330 μ F or 1 x 680 μ F) with an ESR of at least 2 m Ω . This output capacitance is required for the module to meet its transient response specification. For most applications, a high quality computer grade aluminum electrolytic capacitor is suitable. These capacitors provide adequate decoupling over the frequency range, 2 kHz to 150 kHz, and when ambient temperatures are above 0°C. For operation below 0°C, tantalum, ceramic, or Os-Con type capacitors are recommended.

When using one or more nonceramic capacitors, the calculated equivalent ESR should be no lower than 4 m Ω 7 m Ω using the manufacturer's maximum ESR for a single capacitor. A list of preferred low-ESR type capacitors are identified in [Table 1](#).

⚠ Note:

1. This datasheet is downloaded from the website of Murata Manufacturing co., ltd. Therefore, it's specifications are subject to change or our products in it may be discontinued without advance notice. Please check with our sales representatives or product engineers before ordering.
2. This datasheet has only typical specifications because there is no space for detailed specifications. Therefore, please approve our product specifications or transact the approval sheet for product specifications before ordering.

Ceramic Capacitors

Above 150 kHz, the performance of aluminum electrolytic capacitors becomes less effective. To further improve, the reflected input ripple current or the output transient response, multilayer ceramic capacitors can also be added. Ceramic capacitors have very low ESR and their resonant frequency is higher than the bandwidth of the regulator. When used on the output their combined ESR is not critical as long as the total value of ceramic capacitance does not exceed 300 μ F. Also, to prevent the formation of local resonances, do not place more than five identical ceramic capacitors in parallel with values of 10 μ F or greater.

Tantalum Capacitors

Tantalum type capacitors can be used at both the input and output, and are recommended for applications where the ambient operating temperature can be less than 0°C. The AVX TPS, Sprague 593D/594/595, and Kemet T495/ T510 capacitor series are suggested over many other tantalum types due to their higher rated surge, power dissipation, and ripple current capability. As a caution, many general-purpose tantalum capacitors have considerably higher ESR, reduced power dissipation and lower ripple current capability. These capacitors are also less reliable when determining their power dissipation and surge current capability. Tantalum capacitors that do not have a stated ESR or surge current rating are not recommended for power applications. When specifying Os-Con and polymer tantalum capacitors for the output, the minimum ESR limit is encountered before the maximum capacitance value is reached.

Capacitor Table

[Table 1](#) identifies the characteristics of capacitors from a number of vendors with acceptable ESR and ripple current (rms) ratings. The recommended number of capacitors required at both the input and output buses is identified for each capacitor type.

Note: This is not an extensive capacitor list. Capacitors from other vendors are available with comparable specifications. Those listed are for guidance. The RMS ripple current rating and ESR (at 100 kHz) are critical parameters necessary to insure both optimum regulator performance and long capacitor life.

Designing for Very Fast Load Transients

The transient response of the dc/dc converter has been characterized using a load transient with a di/dt of 1 A/ μ s. The typical voltage deviation for this load transient is given in the data sheet specification table using the minimum required value of output capacitance. As the di/dt of a transient is increased, the response of a converter's regulation circuit ultimately depends on its output capacitor decoupling network. This is an inherent limitation with any dc/dc converter once the speed of the transient exceeds its bandwidth capability. If the target application specifies a higher di/dt or lower voltage deviation, the requirement can only be met with additional output capacitor decoupling. In these cases special attention must be paid to the type, value and ESR of the capacitors selected. Additional input capacitance may be required to insure the stability of the input bus during higher current transient di/dt.

MPDTH03020W & MPDTH05020W

Table 1-1; Input / Output Capacitors

Capacitor Vendor, Type Series (Style)	Capacitor Characteristics					Quantity		Vendor Part Number
	Working Voltage	Value (µF)	MAX.(ESR) at 100kHz	Max.Ripple at 85°C Current(Irms)	Physical Size(mm)	Input Bus	Output Bus	
Panasonic FC (Radial) FK (SMD)	10V 10V 10V	1000 1000 1000	0.068Ω 0.0650Ω 0.080Ω	>1050 mA 1205 mA 850 mA	10×16 12.5×16.5 10×10.2	1 1 1	1 1 1	EEUFC1A102 EEVFC1A102LQ EEVFK1A102P
United Chemi-Con FX, Oscon(Radial) PXA, Poly- Aluminum(SMD) PSA (Poly- Aluminum) LXZ, Aluminum (Radial)	6.3V 6.3V 10V 10V	1000 820 680 1000	0.013Ω 0.010Ω 0.007Ω 0.068Ω	4935 mA 5500 mA >5800 mA 1050 mA	10×10.5 10×12.2 10×11.5 10×16	1 2 2 1	1 1 ≤3 1	6FX1000M PXA6.3VC820MJ12TP PSA6.3VB680MJ11 LXZ10VB102M10X16LL
Nichicon, Aluminum HD (Radial) PM (Radial)	6.3V 10V	1000 1000	0.053Ω 0.065Ω	1030 mA 1040 mA	10×12.5 12.5×15	1 1	1 1	UHD0J102MPR UPM1A102MHH6
Sanyo, Os-Con SP, (Radial) SVP, (SMD)	10V 6.3V	470 820	0.015Ω 0.012Ω	>4500 mA >5440 mA	10×10.5 10×12.7	2[2] 2	≤5 ≤43	10SP470M 6SVP820M
Panasonic, Poly-Aluminum: S/SE(SMD)	6.3V	180	0.005Ω	4000mA	7.3×4.3×4.2	N/R	≤2	EEFSE0J181R
AVX, Tantalum, SeriesIII TPS (SMD)	10V 10V	470 470	0.045Ω 0.060Ω	1723 mA 1826 mA	7.3L×5.7W ×4.1H	2[2] 2[2]	≤7 ≤7	TPSE477M010R0045 TPSV447M010R0060
Kemet, Poly-Tantalum T520(SMD) T530 (SMD)	6.3V 10V 6.3V	470 330 470	0.018Ω 0.015Ω 0.012Ω	>1200 mA >3800 mA 4200 mA	4.3W ×7.3L ×4H	2[2] 3 2[2]	≤6 ≤4 ≤3	T520X477M006SE018 T530X337M010AS T530X477M006AS
Vishay-Sprague 595D, Tantalum(SMD) 94SA, Os-con(Radial)	10V 16V	470 2200	0.100Ω 0.015Ω	1440 mA 9740 mA	7.2L×6W× 4.1H 16×25	2[2] 1	≤7 ≤4	595D477X0010R2T 94SA108X0016HBP
Kemet, Ceramic X5R(SMD)	16V 6.3V	10 47	0.002Ω 0.002Ω	-	1210 case 3225mm	1[3] 1[3]	≤9 ≤8	C1210C106M4PAC C1210C476K9PAC
Murata, Ceramic X5R(SMD)	6.3V 6.3V 16V 16V	100 47 22 10	0.002Ω	-	1210case 3225mm	1[3] 1[3] 1[3]	≤4 ≤8 ≤8 ≤9	GRM32ER60J107M GRM32ER60J476M GRM32ER61C226K GRM32DR61C106K
TDK, Ceramic X5R(SMD)	6.3V 6.3V 16V 16V	100 47 22 10	0.002Ω	-	1210case 3225mm	1[3] 1[3] 1[3]	≤4 ≤8 ≤8 ≤9	C3225X5R0J107MT C3225X5R0J476MT C3225X5R1C226MT C3225X5R1C106MT

(1) Capacitor Supplier Verification

Please verify availability of capacitors identified in this table. Capacitor suppliers may recommend alternative part numbers because of limited availability or obsolete products. In some instances, the capacitor product life cycle may be in decline and have short-term consideration for obsolescence.

RoHS, Lead-free and Material Details

Please consult capacitor suppliers regarding material composition, RoHS status, lead-free status, and manufacturing process requirements. Component designators or part number deviations can occur when material composition or soldering requirements are updated.

(2) The total capacitance is slightly lower than 1000µF, but is acceptable based on the combined ripple current rating.

(3) Ceramic capacitors can be used to complement electrolytic types at the input to further reduce high-frequency ripple current.

⚠ Note:

- This datasheet is downloaded from the website of Murata Manufacturing co., ltd. Therefore, it's specifications are subject to change or our products in it may be discontinued without advance notice. Please check with our sales representatives or product engineers before ordering.
- This datasheet has only typical specifications because there is no space for detailed specifications. Therefore, please approve our product specifications or transact the approval sheet for product specifications before ordering.

Adjusting the Output Voltage of the MPDTH04040W Wide-Output Adjust Power Module

The V_O Adjust control (pin 17) sets the output voltage of the MPDTH04040W to a value higher than 0.8 V. The adjustment range is from 0.8 V to 2.5 V. For an output voltage other than 0.8 V a single external resistor, R_{SET} , must be connected directly between the V_O Adjust (pin 17) and the output GND (pin 16)⁽²⁾.

Table 2 gives the preferred value of the external resistor for a number of standard voltages, along with the actual output voltage that this resistance value provides.

For other output voltages, the value of the required resistor is calculated using the following formula, or by selecting from the range of values given in Table 3. Figure 9 shows the placement of the required resistor.

$$R_{set} = 10 \text{ k}\Omega \cdot \frac{0.8\text{V}}{V_{out}-0.8} - 2.49 \text{ k}\Omega \quad (1)$$

Table 2: Preferred Values of Rset for Standard Output Voltages

Vout(Standard) ⁽¹⁾	Rset(Preferred Value)	Vout(Actual)
2.5V	2.21Ω	2.502V
2V	4.12Ω	2.010V
1.8V	5.49Ω	1.803V
1.5V	8.87Ω	1.504V
1.2V	17.4Ω	1.202V
1V	36.5Ω	1.005V
0.8V	Open	0.8V

(1)The nominal input voltage must be at least $2 \times V_o$. Output voltage regulation is guaranteed with an input voltage within $\pm 10\%$ from nominal 3.3V or 5V. For example, for $V_i=5\text{V}$ and $V_o=2.5\text{V}$, the input can vary between 4.5V and 5.5V.

Figure 9: V_o Adjust Resistor Placement

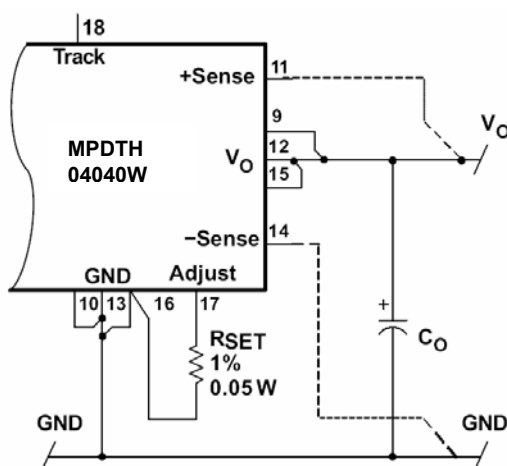

⚠ Note:

1. This datasheet is downloaded from the website of Murata Manufacturing co., Ltd. Therefore, it's specifications are subject to change or our products in it may be discontinued without advance notice. Please check with our sales representatives or product engineers before ordering.
2. This datasheet has only typical specifications because there is no space for detailed specifications. Therefore, please approve our product specifications or transact the approval sheet for product specifications before ordering.

Table 3: Output Voltage Set-Point Resistor Values

V_o	Rset	V_o	Rset
0.800	Open	1.425	10.3 kΩ
0.825	318 kΩ	1.450	9.82 kΩ
0.850	158 kΩ	1.475	9.36 kΩ
0.875	104 kΩ	1.50	8.94 kΩ
0.900	77.5 kΩ	1.55	8.18 kΩ
0.925	61.5 kΩ	1.60	7.51 kΩ
0.950	50.8 kΩ	1.65	6.92 kΩ
0.975	43.2 kΩ	1.70	6.4 kΩ
1.000	37.5 kΩ	1.75	5.93 kΩ
1.025	33.1 kΩ	1.80	5.51 kΩ
1.050	29.5 kΩ	1.85	5.13 kΩ
1.075	26.6 kΩ	1.90	4.78 kΩ
1.100	24.2 kΩ	1.95	4.47 kΩ
1.125	22.1 kΩ	2.00	4.18 kΩ
1.150	20.4 kΩ	2.05	3.91 kΩ
1.175	18.8 kΩ	2.10	3.66 kΩ
1.200	17.5 kΩ	2.15	3.44 kΩ
1.225	16.3 kΩ	2.20	3.22 kΩ
1.250	15.3 kΩ	2.25	3.03 kΩ
1.275	14.4 kΩ	2.30	2.84 kΩ
1.300	13.5 kΩ	2.35	2.67 kΩ
1.325	12.7 kΩ	2.40	2.51 kΩ
1.350	12.1 kΩ	2.45	2.36 kΩ
1.375	11.4 kΩ	2.50	2.22 kΩ
1.400	10.8 kΩ		

Notes:

1. A 0.05-W rated resistor can be used. The tolerance should be 1%, with temperature stability of 100 ppm/°C (or better). Place the resistor as close to the regulator as possible. Connect the resistor directly between pins 17 and 16 using dedicated PCB traces.
2. Never connect capacitors from V_o Adjust to either GND or V_o . Any capacitance added to the V_o Adjust pin affects the stability of the regulator.

Adjusting the Undervoltage Lockout(UVLO) of the MPDTH04040W Power Modules

The MPDTH04040W power modules incorporate an input undervoltage lockout (UVLO). The UVLO feature prevents the operation of the module until there is sufficient input voltage to produce a valid output voltage. This enables the module to provide a monotonic powerup for the load circuit, and also limits the magnitude of current drawn from the module's input source during the power-up sequence.

The UVLO characteristic is defined by the on-threshold (V_{THD}) and hysteresis (V_{HYS}) voltages. Below the on threshold, the Inhibit control is overridden, and the module does not produce an output. Hysteresis voltage is the difference between the on and off threshold voltages. It ensures a clean power-up, even when the input voltage is rising slowly. The hysteresis prevents start-up oscillations, which can occur if the input voltage droops slightly when the module begins drawing current from the input source.

UVLO Adjustment

The UVLO feature of the MPDTH04040W gives the user the option of adjusting the on-threshold voltage higher than the default value. This might be desirable if the module is powered from a 5-V input bus. This prevents the module from operating until the input bus has risen closer to its regulation voltage.

The adjustment method uses the *UVLO Prog* control (pin 8). If the *UVLO Prog* pin is left open circuit, the onthreshold voltage remains at its nominal value of 2.63 V (see electrical specification table). This ensures that the unadjusted module produces a regulated output when the minimum input voltage is applied. The hysteresis voltage is approximately 0.62 V, which correlates to an off-threshold voltage of about 2 V. The magnitude of the hysteresis is automatically set to about 22% of the onthreshold. So if the on-threshold voltage is increased, then the hysteresis also increases.

Adjustment Method

Figure 10 shows the placement of the resistor, R_{THD} , for adjusting the UVLO on-threshold voltage. It connects from the *UVLO Prog* control pin to *GND*. Equation 2 determines the value of R_{THD} required to adjust V_{THD} to a new value. The default value is 2.63 V, and it can only be adjusted higher. Once the value of R_{THD} has been set, Equation 3 is used to determine the new hysteresis voltage.

$$R_{THD} = \frac{12.9}{V_{THD}-2.63} \text{ k}\Omega \quad (2)$$

$$V_{HYS} = 2.191 \left[\frac{1}{R_{THD}} + 0.283 \right] \text{ V} \quad (3)$$

Figure 10; UVLO Program Resistor Placement

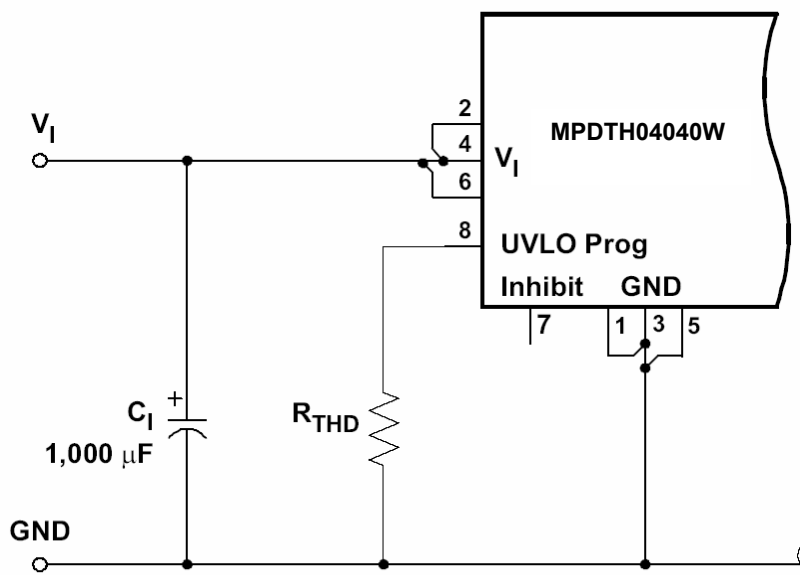

⚠ Note:

1. This datasheet is downloaded from the website of Murata Manufacturing co., Ltd. Therefore, it's specifications are subject to change or our products in it may be discontinued without advance notice. Please check with our sales representatives or product engineers before ordering.
2. This datasheet has only typical specifications because there is no space for detailed specifications. Therefore, please approve our product specifications or transact the approval sheet for product specifications before ordering.

Features of the MPDTH Family of Nonisolated Wide Output Adjust Power Modules

POLA™ Compatibility

The MPDTH family of nonisolated, wide-output adjustable power modules are optimized for applications that require a flexible, high performance module that is small in size. Each of these products are POLA™ compatible.

POLA-compatible products are produced by a number of manufacturers, and offer customers advanced, nonisolated modules with the same footprint and form factor. POLA parts are also assured to be interoperable, thereby providing customers with second-source availability.

Many of the POLA-compatible parts include a feature called Auto-Track™. Auto-Track was specifically designed to simplify the task of sequencing the supply voltages in a power system. This and other features are described the following sections.

Soft-Start Power Up

The Auto-Track feature allows the power-up of multiple MPDTH modules to be directly controlled from the Track pin.

However in a stand-alone configuration, or when the Auto-Track feature is not being used, the Track pin should be directly connected to the input voltage, VI (see Figure 11).

Figure 11; Power-Up Application Circuit

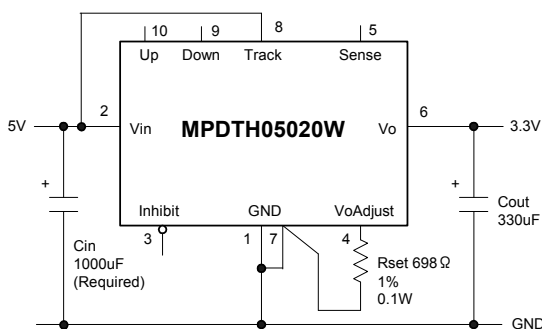

When the Track pin is connected to the input voltage the Auto-Track function is permanently disengaged. This allows the module to power up entirely under the control of its internal soft-start circuitry. When power up is under soft-start control, the output voltage rises to the set-point at a quicker and more linear rate.

From the moment a valid input voltage is applied, the soft-start control introduces a short time delay (typically 5 ms–10 ms) before allowing the output voltage to rise.

⚠ Note:

1. This datasheet is downloaded from the website of Murata Manufacturing co., Ltd. Therefore, it's specifications are subject to change or our products in it may be discontinued without advance notice. Please check with our sales representatives or product engineers before ordering.
2. This datasheet has only typical specifications because there is no space for detailed specifications. Therefore, please approve our product specifications or transact the approval sheet for product specifications before ordering.

Figure 12; Power-Up Waveforms

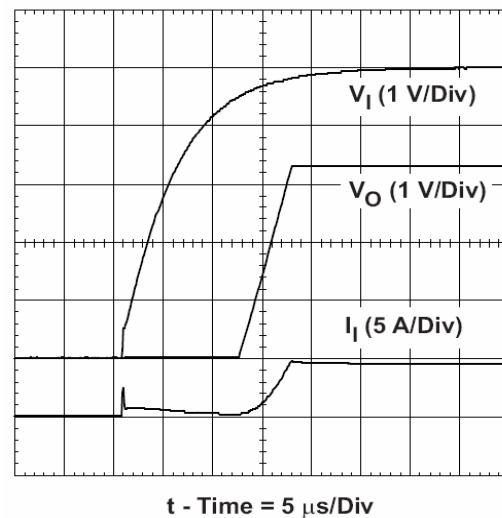

The output then progressively rises to the module's setpoint voltage. Figure 12 shows the soft-start power-up characteristic of the 22-A output product (MPDTH05020W), operating from a 5-V input bus and configured for a 3.3-V output. The waveforms were measured with a 5-A resistive load and the Auto-Track feature disabled. The initial rise in input current when the input voltage first starts to rise is the charge current drawn by the input capacitors. Power-up is complete within 15 ms.

Over-Current Protection

For protection against load faults, all modules incorporate output overcurrent protection. Applying a load that exceeds the regulator's overcurrent threshold causes the regulated output to shut down. Following shutdown, a module periodically attempts to recover by initiating a soft-start powerup. This is described as a *hiccup* mode of operation, whereby the module continues in a cycle of successive shutdown and power up until the load fault is removed. During this period, the average current flowing into the fault is significantly reduced. Once the fault is removed, the module automatically recovers and returns to normal operation.

Over-Temperature Protection (OTP)

Products with a high output current capability (>20 A), incorporate overtemperature protection. This feature is provided by an on-board temperature sensor that protects the module's internal circuitry against excessively high temperatures. A rise in the internal temperature may be the result of a drop in airflow, or a high ambient temperature. If the internal temperature exceeds the OTP threshold, the module's Inhibit control is automatically pulled low. This turns the output off. The output voltage drops as the external output capacitors are discharged by the load circuit. The recovery is automatic, and begins with a soft-start power up. It occurs when the sensed temperature decreases by about 10°C below the trip point. *Note: The overtemperature protection is a last resort mechanism to prevent thermal stress to the regulator. Operation at or close to the thermal shutdown temperature is not recommended, and reduces the long-term reliability of the module. Always operate the regulator within the specified safe operating area (SOA) limits for the worst-case conditions of ambient temperature and airflow.*

Output On/Off Inhibit

For applications requiring output voltage on/off control, each series of the MPDTH family incorporates an output *Inhibit* control pin. The inhibit feature can be used wherever there is a requirement for the output voltage from the regulator to be turned off.

The power modules function normally when the Inhibit pin is left open-circuit, providing a regulated output whenever a valid source voltage is connected to V_{in} with respect to GND .

Figure 13 shows the typical application of the inhibit function. Note the discrete transistor (Q1). The *Inhibit* control has its own internal pull-up to V_1 potential. The input is not compatible with TTL logic devices. An open-collector (or open-drain) discrete transistor is recommended for control.

Figure 13: Inhibit Control Circuit

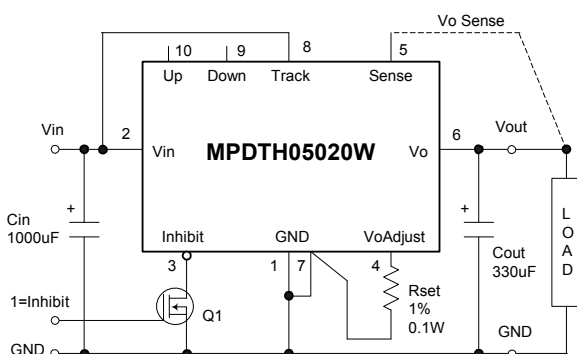

⚠ Note:

1. This datasheet is downloaded from the website of Murata Manufacturing co., ltd. Therefore, it's specifications are subject to change or our products in it may be discontinued without advance notice. Please check with our sales representatives or product engineers before ordering.
2. This datasheet has only typical specifications because there is no space for detailed specifications. Therefore, please approve our product specifications or transact the approval sheet for product specifications before ordering.

Turning Q1 on applies a low voltage to the *Inhibit* control and disables the output of the module. If Q1 is then turned off, the module executes a soft-start powerup. A regulated output voltage is produced within 20 ms.

Figure 14 shows the typical rise in both the output voltage and input current, following the turn-off of Q1. The turn off of Q1 corresponds to the rise in the waveform, Q1 Vds. The waveforms were measured with a 5-A constant current load.

Figure 14: Power-Up from Inhibit Control

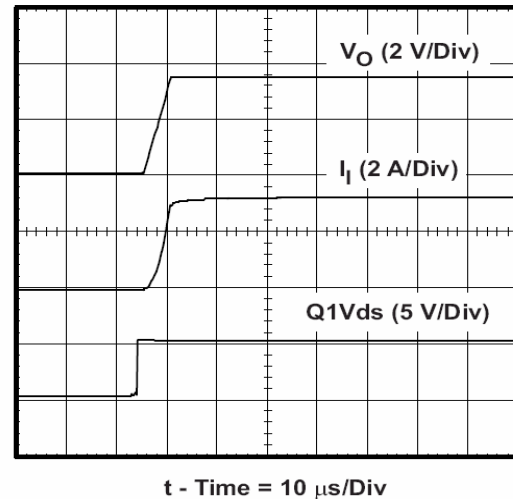

Remote Sense

The remote sense feature allows the regulator to compensate for limited amounts of voltage drop, that may be incurred between the converter and load, due to resistance in the PCB traces. Connecting the *+Sense* and *-Sense* pins to the respective V_O and GND output nodes improves the load regulation of the regulator output at those connection points. This is recommended even if the load circuit is located close to the module.

If either the *+Sense* and *-Sense* are left open-circuit, an internal low-value resistor (15-Ω or less), connected from the respective sense pin to either V_O or GND , ensures the output voltage remains in regulation.

With the sense pins connected, the difference between the voltage measured across the V_O and GND pins of the regulator, and that measured at *+Sense* with respect to *+Sense*, is the amount of IR drop being compensated by the regulator. This should be limited to a maximum of 0.3 V.

Note: The remote sense feature is not designed to compensate for the forward drop of nonlinear or frequency dependent components that may be placed in series with the converter output. Examples include OR-ing diodes, filter inductors, ferrite beads, and fuses. When these components are enclosed by the remote sense connection they are effectively placed inside the regulation control loop, which can adversely affect the stability of the regulator.

Auto-Track™ Function

The Auto-Track function is unique to the MPDTH family, and is available with all POLA-compatible products. Auto-Track was designed to simplify the amount of circuitry required to make the output voltage from each module power up and power down in sequence. The sequencing of two or more supply voltages during power up is a common requirement for complex mixed-signal applications that use dual-voltage VLSI ICs such as the TMS320™ DSP family, micro-processors, and ASICs.

How Auto-Track™ Works

Auto-Track works by forcing the module's output voltage to follow a voltage presented at the *Track* control pin. This control range is limited to between 0 V and the module's set-point voltage. Once the *Track* input is raised above the set-point voltage, the module's output remains at its set-point voltage. As an example, if the *Track* pin of a 2.5-V regulator is at 1 V, the regulated output will be 1 V. But, if the voltage at the *Track* pin rises to 3 V, the regulated output does not go higher than 2.5 V.

When the *Track* input is used to connect a number of modules together, it forces the output voltage from each module to follow a common signal during power-up and power-down. The control signal can be an externally generated master ramp waveform, or the output voltage from another power supply circuit.⁽³⁾ For convenience, each module's *Track* input incorporates an internal RC charge circuit. This operates off the module's input voltage to provide a suitable rising voltage ramp waveform.

Typical Application

Connecting the *Track* inputs of two or more modules forces their *Track* input to follow the same collective RC ramp waveform, and allows their power-up sequence to be coordinated from a common *Track* control signal. This can be an open-collector (or open drain) device, such as a power-up reset voltage supervisor IC.

To coordinate a power-up sequence the *Track* control must first be pulled to ground potential. This should be done at or before input power is applied to the modules. The ground signal should be maintained for at least 10 ms after input power has been applied. This brief period gives the modules time to complete their internal soft-start initialization, enabling them to produce an output voltage. A low-cost supply voltage supervisor IC, that includes built-in time delay, is an ideal component for automatically controlling the *Track* inputs at power up.

Figure 15 shows how the TPS3808G50 supply voltage supervisor IC (U3) can be used to coordinate the sequenced power-up of two 5-V input Auto-Track modules. The output of the TPS3808 supervisor becomes active above an input voltage of 0.8 V, enabling it to assert a ground signal to the common *Track* control well before the input voltage has reached the module's undervoltage lockout threshold. The ground signal is maintained until approximately 27 ms after the input voltage has risen above U3's voltage threshold, which is 4.65 V. The 27-ms time period is controlled by the capacitor C3.

The value of 4700µF provides sufficient time delay for the modules to complete their internal soft-start initialization. The output voltage of each module remains at zero until the *Track* control voltage is allowed to rise. When U3 removes the ground signal, the *Track* control voltage automatically rises to the input voltage. This causes the output voltage of each module to rise simultaneously with the other modules, until each reaches its respective set-point voltage.

Figure 15 shows the output voltage waveforms from the circuit of Figure 16 after input voltage is applied to the circuit. The waveforms, V_{O1} and V_{O2} , represent the output voltages from the two power modules, U1 (3.3 V) and U2 (1.8 V), respectively. V_{TRK} , V_{O1} , and V_{O2} are shown rising together to produce the desired simultaneous power-up characteristic.

The same circuit also provides a power-down sequence. When the input voltage falls below U3's voltage threshold, the ground signal is re-applied to the common *Track* control. This pulls the *Track* inputs to zero volts, forcing the output of each module to follow, as shown in Figure 17. In order for a simultaneous power-down to occur, the *Track* inputs must be pulled low before the input voltage has fallen below the modules' undervoltage lockout. This is an important constraint. Once the modules recognize that a valid input voltage is no longer present, their outputs can no longer follow the voltage applied at their *Track* input. During a power-down sequence, the fall in the output voltage from the modules is limited by the maximum output capacitance and the Auto-Track slew rate.

Notes on Use of Auto-Track™

1. The *Track* pin voltage must be allowed to rise above the module's set-point voltage before the module can regulate at its adjusted set-point voltage.
2. The Auto-Track function tracks almost any voltage ramp during power up, and is compatible with ramp speeds of up to 1 V/ms.
3. The absolute maximum voltage that may be applied to the *Track* pin is V_I .
4. The module does not follow a voltage at its *Track* input until it has completed its soft-start initialization. This takes at least 10 ms from the time that the module has sensed that a valid voltage is present. During this period, the *Track* input should be held at ground potential.
5. The module is capable of both sinking and sourcing current when following a voltage at its *Track* input. Therefore startup into an output prebias is not supported when the module is under Auto-Track control. Prebias holdoff is not necessary when all supply voltages simultaneously under the control of Auto-Track.
6. The Auto-Track function can be disabled by connecting the *Track* pin to the input voltage (V_I). With Auto-Track disabled, the output voltage rises at a quicker and more linear rate after input power is applied.

⚠ Note:

1. This datasheet is downloaded from the website of Murata Manufacturing co., Ltd. Therefore, it's specifications are subject to change or our products in it may be discontinued without advance notice. Please check with our sales representatives or product engineers before ordering.
2. This datasheet has only typical specifications because there is no space for detailed specifications. Therefore, please approve our product specifications or transact the approval sheet for product specifications before ordering.

Figure 3-5; Sequenced Power Up & Power Down Using Auto-Track

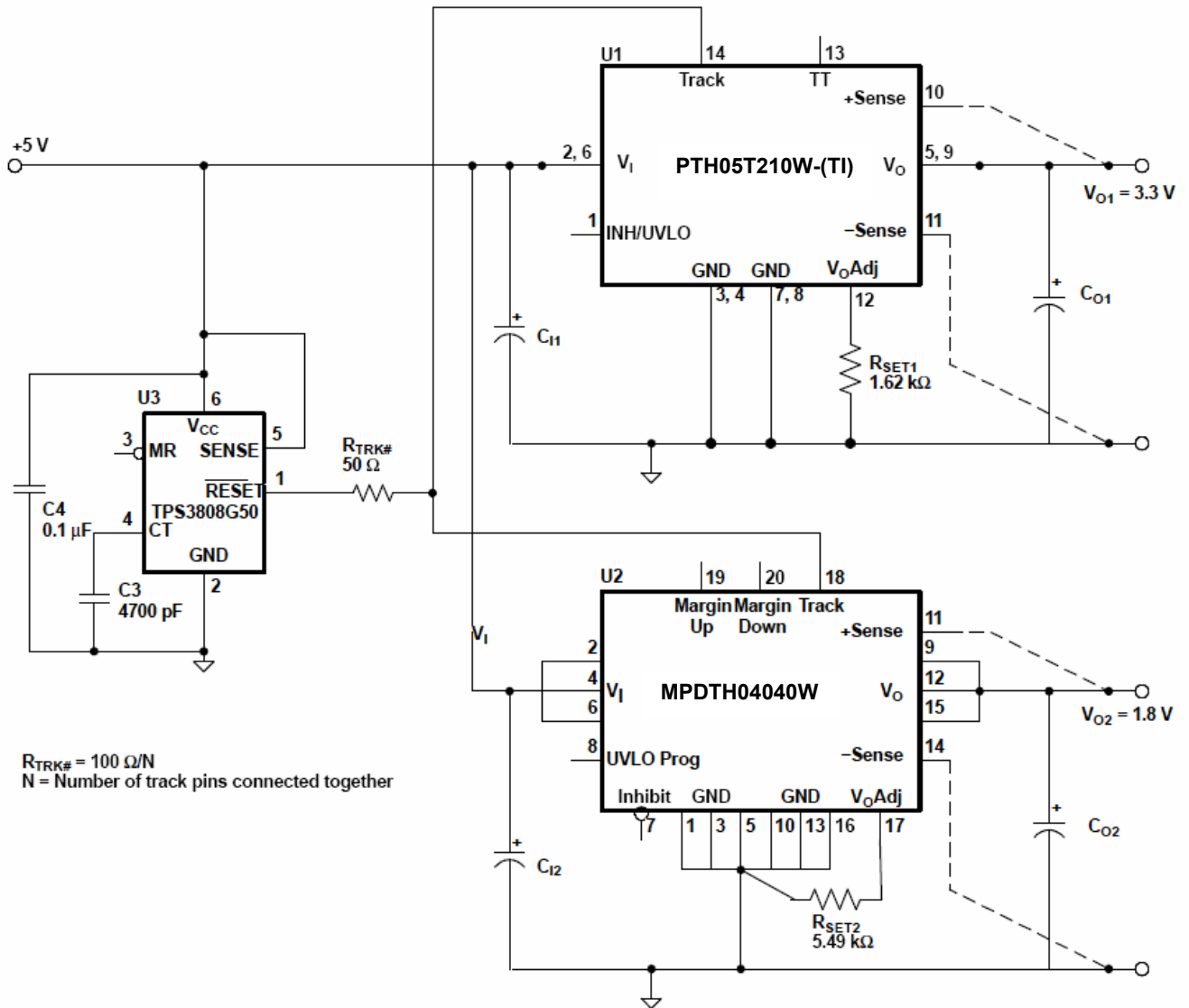
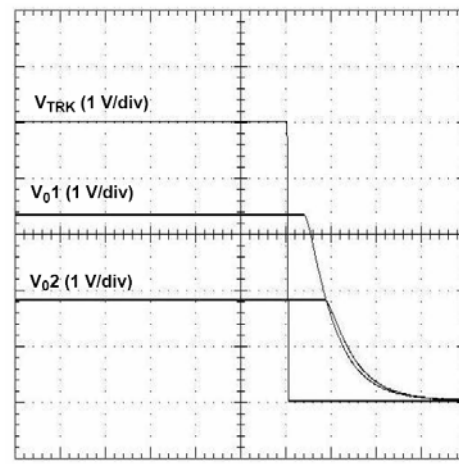
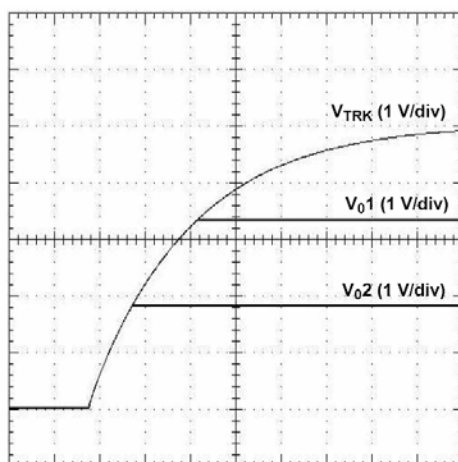

Figure 16: Auto-Track Simultaneous Power Up Waveforms

Figure 17: Auto-Track Simultaneous Power Down Waveforms



⚠ Note:

1. This datasheet is downloaded from the website of Murata Manufacturing co., Ltd. Therefore, it's specifications are subject to change or our products in it may be discontinued without advance notice. Please check with our sales representatives or product engineers before ordering.
2. This datasheet has only typical specifications because there is no space for detailed specifications. Therefore, please approve our product specifications or transact the approval sheet for product specifications before ordering.

Margin Up/Down Controls

The MPDTH**060, MPDTH**010, MPDTH**020, and MPDTH**030 products incorporate *Margin Up* and *Margin Down* control inputs. These controls allow the output voltage to be momentarily adjusted⁽¹⁾, either up or down, by a nominal 5%. This provides a convenient method for dynamically testing the operation of the load circuit over its supply margin or range. It can also be used to verify the function of supply voltage supervisors. The $\pm 5\%$ change is applied to the adjusted output voltage, as set by the external resistor, R_{set} at the $V_o Adjust$ pin.

The 5% adjustment is made by pulling the appropriate margin control input directly to the GND terminal 2. A low-leakage open-drain device, such as an n-channel MOSFET or -channel JFET is recommended for this purpose⁽³⁾. Adjustments of less than 5% can also be accommodated by adding series resistors to the control inputs. The value of the resistor can be selected from [Table 4](#), or calculated using the following formula.

Up/Down Adjust Resistance Calculation

$$R_{U \text{ or } D} = \frac{499}{\Delta\%} - 99.8 \quad \text{k}\Omega \quad (4)$$

Where $\Delta\%$ = The desired amount of margin adjust in percent.

Notes

1. The *Margin Up* and *Margin Down* controls were not intended to be activated simultaneously. If they are activated simultaneously, the effects on the output voltage may not completely cancel, resulting in the possibility of a higher error in the output voltage set point.
2. The ground reference should be a direct connection to the module *GND* at pin 7 (pin 1 for the MPDTHxx050). This produces a more accurate adjustment at the load circuit terminals. The transistors Q1 and Q2 should be located close to the regulator.
3. The Margin Up and Margin Down control inputs are not compatible with devices that source voltage. This includes TTL logic. These are analog inputs and should only be controlled with a true open-drain device (preferably discrete MOSFET transistor). The device selected should have low off-state leakage current. Each input sources $8 \mu\text{A}$ when grounded, and has an open-circuit voltage of 0.8 V.

Table 4; Margin Up/Down Resistor Values

%Adjust	RU / RD
5	0k Ω
4	24.9k Ω
3	66.5k Ω
2	150k Ω
1	397k Ω

Figure 3-8; Margin Up/Down Application Schematic

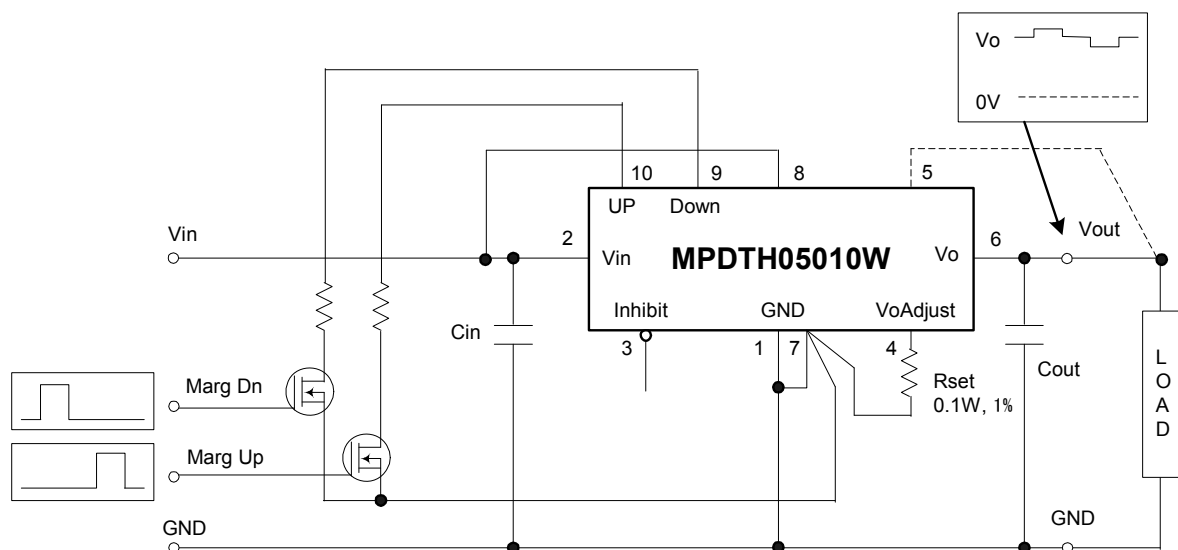

⚠ Note:

1. This datasheet is downloaded from the website of Murata Manufacturing co., ltd. Therefore, it's specifications are subject to change or our products in it may be discontinued without advance notice. Please check with our sales representatives or product engineers before ordering.
2. This datasheet has only typical specifications because there is no space for detailed specifications. Therefore, please approve our product specifications or transact the approval sheet for product specifications before ordering.

Pre-Bias Startup Capability

A prebias startup condition occurs as a result of an external voltage being present at the output of a power module prior to its output becoming active. This often occurs in complex digital systems when current from another power source is backed through a dual-supply logic component, such as an FPGA or ASIC. Another path might be via clamp diodes as part of a dual-supply power-up sequencing arrangement. A prebias can cause problems with power modules that incorporate synchronous rectifiers. This is because under most operating conditions, these types of modules can sink as well as source output current.

The MPDTH family of power modules incorporate synchronous rectifiers, but does not sink current during startup⁽¹⁾, or whenever the Inhibit pin is held low. However, to ensure satisfactory operation of this function, certain conditions must be maintained⁽²⁾. Figure 20 shows an application demonstrating the prebias startup capability. The start-up waveforms are shown in Figure 19. Note that the output current from the MPDTH03010W (I_o) shows negligible current until its output voltage rises above that backed through diodes D1 and D2.

Note: The prebias start-up feature is not compatible with Auto-Track. When the module is under Auto-Track control, it sinks current if the output voltage is below that of a back-feeding source. To ensure a prebias hold-off, one of two approaches must be followed when input power is applied to the module. The Auto-Track function must be disabled⁽³⁾, or the module's output held off (for at least 50 ms) using the Inhibit pin. Either approach ensures that the Track pin voltage is above the set-point voltage at start up.

Notes

1. Startup includes the short delay (approximately 10 ms) prior to the output voltage rising, followed by the rise of the output voltage under the module's internal soft-start control. Startup is complete when the output voltage has risen to either the set-point voltage or the voltage at the Track pin, whichever is lowest.
2. To ensure that the regulator does not sink current when power is first applied (even with a ground signal applied to the Inhibit control pin), the input voltage *must* always be greater than the output voltage *throughout* the powerup and power-down sequence.
3. The Auto-Track function can be disabled at power up by immediately applying a voltage to the module's Track pin that is greater than its set-point voltage. This can be easily accomplished by connecting the Track pin to Vin.

Figure 19; Pre-Bias Startup Waveforms

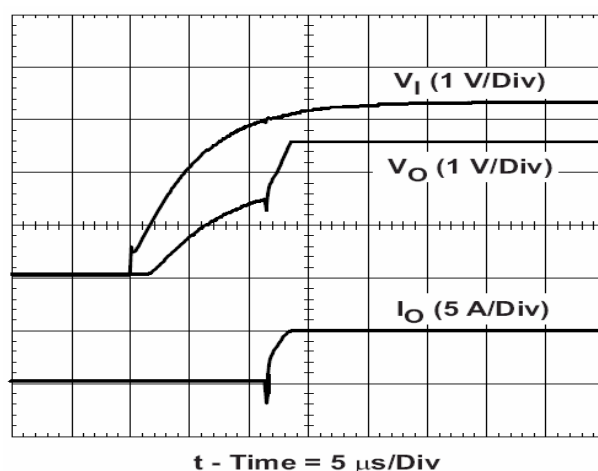
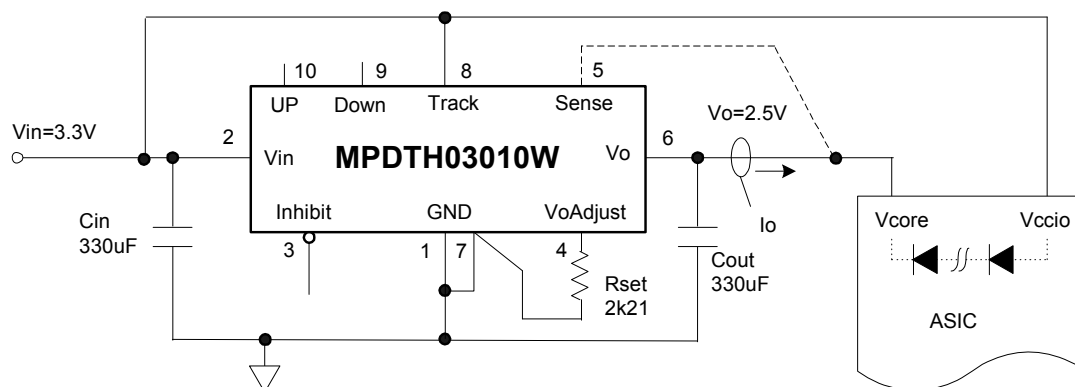

Figure 20; Application Circuit Demonstrating Pre-Bias Startup



⚠ Note:

1. This datasheet is downloaded from the website of Murata Manufacturing co., Ltd. Therefore, it's specifications are subject to change or our products in it may be discontinued without advance notice. Please check with our sales representatives or product engineers before ordering.
2. This datasheet has only typical specifications because there is no space for detailed specifications. Therefore, please approve our product specifications or transact the approval sheet for product specifications before ordering.

Mechanical Data

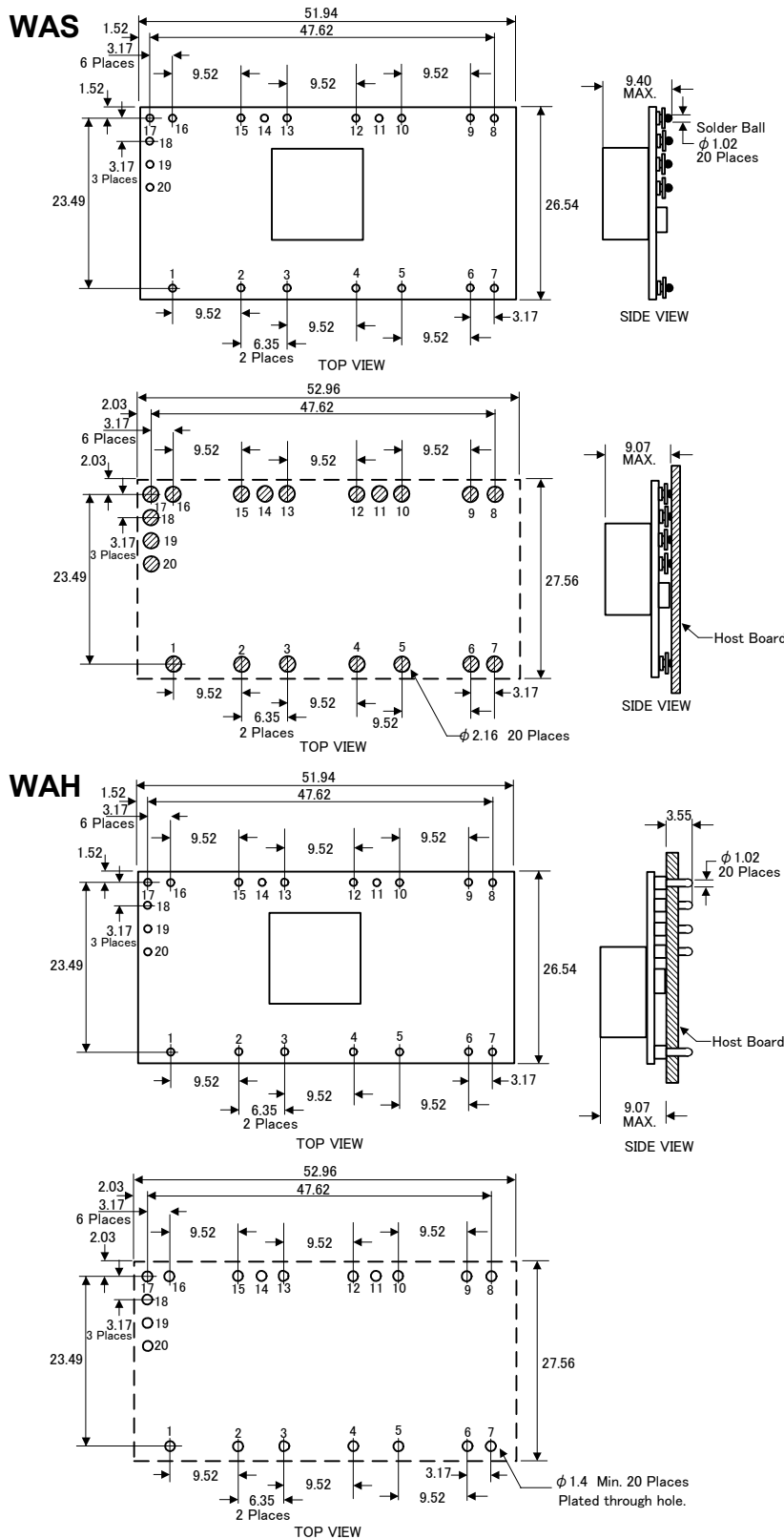

Unit: mm

Tolerance ± 0.25

⚠ Note:

1. This datasheet is downloaded from the website of Murata Manufacturing co., Ltd. Therefore, it's specifications are subject to change or our products in it may be discontinued without advance notice. Please check with our sales representatives or product engineers before ordering.
2. This datasheet has only typical specifications because there is no space for detailed specifications. Therefore, please approve our product specifications or transact the approval sheet for product specifications before ordering.

IMPORTANT NOTICE

Murata Manufacturing Co., Ltd. and its subsidiaries (Murata) reserve the right to make corrections, modifications, enhancements, improvements, and other changes to its products and services at any time and to discontinue any product or service without notice. Customers should obtain the latest relevant information before placing orders and should verify that such information is current and complete. All products are sold subject to Murata's terms and conditions of sale supplied at the time of order acknowledgment.

Murata warrants performance of its hardware products to the specifications applicable at the time of sale in accordance with Murata's standard warranty. Testing and other quality control techniques are used to the extent Murata deems necessary to support this warranty. Except where mandated by government requirements, testing of all parameters of each product is not necessarily performed.

Murata assumes no liability for applications assistance or customer product design. Customers are responsible for their products and applications using Murata components. To minimize the risks associated with customer products and applications, customers should provide adequate design and operating safeguards.

Murata does not warrant or represent that any license, either express or implied, is granted under any Murata patent right, copyright, or other Murata intellectual property right relating to any combination, machine, or process in which Murata products or services are used. Information published by Murata regarding third-party products or services does not constitute a license from Murata to use such products or services or a warranty or endorsement thereof. Use of such information may require a license from a third party under the patents or other intellectual property of the third party, or a license from Murata under the patents or other intellectual property of Murata.

Reproduction of information in Murata data books or data sheets is permissible only if reproduction is without alteration and is accompanied by all associated warranties, conditions, limitations, and notices. Reproduction of this information with alteration is an unfair and deceptive business practice. Murata is not responsible or liable for such altered documentation.

Resale of Murata products or services with statements different from or beyond the parameters stated by Murata for that product or service voids all express and any implied warranties for the associated Murata product or service and is an unfair and deceptive business practice. MURATA is not responsible or liable for any such statements.

Copyright 2007, Murata Manufacturing Co., Ltd.

⚠ Note:

1. This datasheet is downloaded from the website of Murata Manufacturing co., ltd. Therefore, it's specifications are subject to change or our products in it may be discontinued without advance notice. Please check with our sales representatives or product engineers before ordering.
2. This datasheet has only typical specifications because there is no space for detailed specifications. Therefore, please approve our product specifications or transact the approval sheet for product specifications before ordering.