

DC-DC Converter Application Manual

MYUSP3R303FMP

1. Features

- Ultra small size foot print (8.5mm × 11.0mm), 3A output current, non-isolated POL.
- Wide adjustable output voltage range by connecting external resistance (0.7V to 3.3V).
- Wide operating temperature (-40 °C to +85 °C) .
- UVLO function, ON/OFF function, P-GOOD function, Output voltage sense function, Over-current function and, Over-temperature function are built in.

2. Appearance, Dimensions

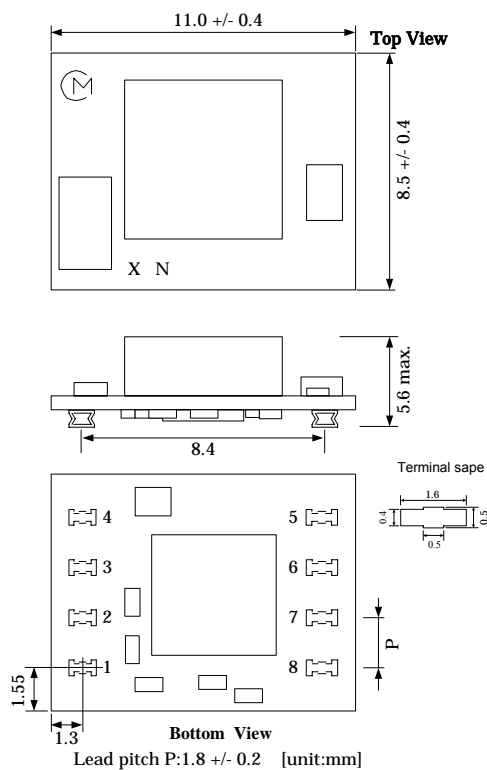

Marking

- | | |
|---------------------------|----|
| (1) Pin No.1 Side Marking | Ⓜ |
| (2) Parts Number | XN |
| (3) Manufacturer ID | Ⓜ |
| (4) Lot No. | |

Production Year

Production Month (1,2,3,...9,O,N,D)

Production Control Marking

⚠ Note:

1. This datasheet is downloaded from the website of Murata Manufacturing co., ltd. Therefore, it's specifications are subject to change or our products in it may be discontinued without advance notice. Please check with our sales representatives or product engineers before ordering.
2. This datasheet has only typical specifications because there is no space for detailed specifications. Therefore, please approve our product specifications or transact the approval sheet for product specifications before ordering.

Pin Number and Function

Pin No.	Symbol	Function
1	TRIM	Output voltage adjustment
2	Vout	Output
3,5	GND	GND
4	+SENSE	Output voltage sense
6	ON/OFF	Remote ON/OFF
7	Vin	Input
8	Pgood	Power good output

3. Block Diagram

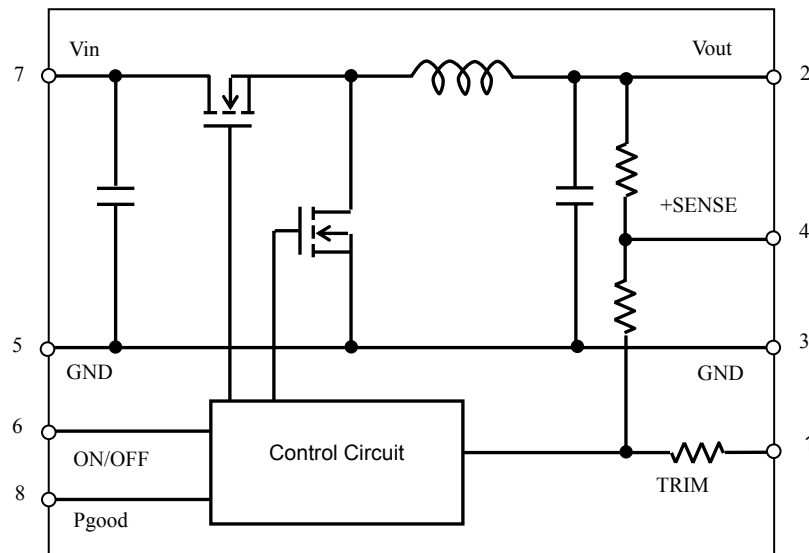

4. Test Circuit

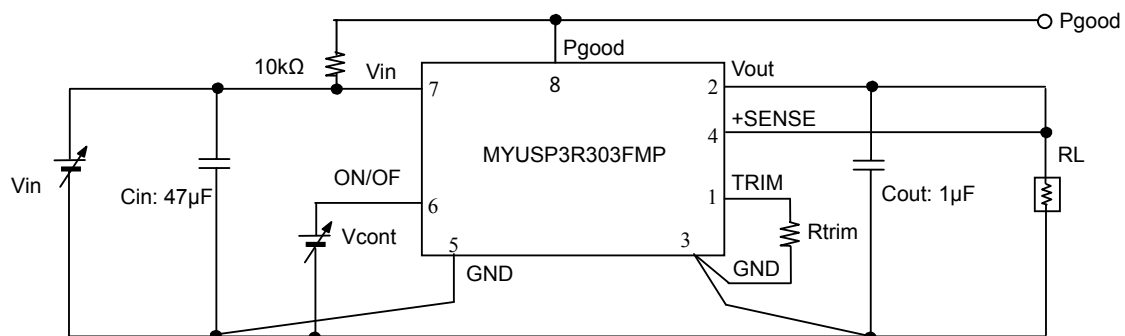

Cin : 47μF / 6.3V Ceramic Capacitor
 Cout : 1μF / 10V Ceramic Capacitor

Please make sure to place Cin and Cout nearby input and output terminal of DC-DC converter.

⚠ Note:

1. This datasheet is downloaded from the website of Murata Manufacturing co., ltd. Therefore, it's specifications are subject to change or our products in it may be discontinued without advance notice. Please check with our sales representatives or product engineers before ordering.
2. This datasheet has only typical specifications because there is no space for detailed specifications. Therefore, please approve our product specifications or transact the approval sheet for product specifications before ordering.

5. Characteristics

5. 1 Electrical Characteristics (Ta=25 °C)

Item	Symbol	Condition	Value			Unit	
			Min.	Typ.	Max.		
Input Voltage Range	Vin		3.0	-	5.5	V	
Output Voltage Adjustable Range	Vout	Vin=3.0V-5.5V Note : VinMin.=Vout+1.2V at Vout 1.6V	0.7	-	3.3	V	
Output Voltage Tolerance	Vo tol	Over Vin, Temperature range Rset=0.5% tolerance Io=5mA ~ 3A	-3.0	-	+3.0	%Vo	
Output Current	Iout	See the thermal derating curve in section 5.2.	0	-	3	A	
Ripple Voltage	Vrpl	Vin=5V, Vout=1.2V, Iout=3A BW =20MHz,	-	-	80	mV(pp)	
Efficiency	EFF	Vin =5V, Vout=3.3V, Iout=1A	-	94	-	%	
ON/OFF pin High Voltage	VIH		ON	2.0	-	Vin	V
ON/OFF pin Low Voltage	VIL		OFF	0	-	0.8	V
Short Circuit Protection	SCP	When a short circuit state continues, the product becomes the latch up mode and stops.. After correction of the abnormal condition, the DC-DC Converter will restart by re-inputting Vin or toggling On/Off pin.					
Power Good Detection Theshold	Vpg			-10		%Vo	
Soft Start Time	TSS		2	4	8	msec	
Timer Latch Mask Time	Tlatch		0.5	1	2	msec	

*Power Good Detection output is sent when the DC-DC converter begins the output operation (when the output voltage reaches a threshold voltage of Power Good Detection shown in 9.1.3.). PGOOD pin is open drain output

DC-DC converter is operating : PGOOD-PIN is open.

DC-DC converter is not operating : PGOOD-PIN is pull down to GND internally.

 Caution

The above electrical characteristics are guaranteed with the condition that the impedance of the input voltage source is sufficiently low as shown in section 4. Connecting an input inductance or using an input power supply with output inductance may cause an unstable operation of this device. Please check the proper operation of this device with the peripheral circuits on your system.

 Note:

1. This datasheet is downloaded from the website of Murata Manufacturing co., ltd. Therefore, it's specifications are subject to change or our products in it may be discontinued without advance notice. Please check with our sales representatives or product engineers before ordering.
2. This datasheet has only typical specifications because there is no space for detailed specifications. Therefore, please approve our product specifications or transact the approval sheet for product specifications before ordering.

5. 2 Thermal Derating

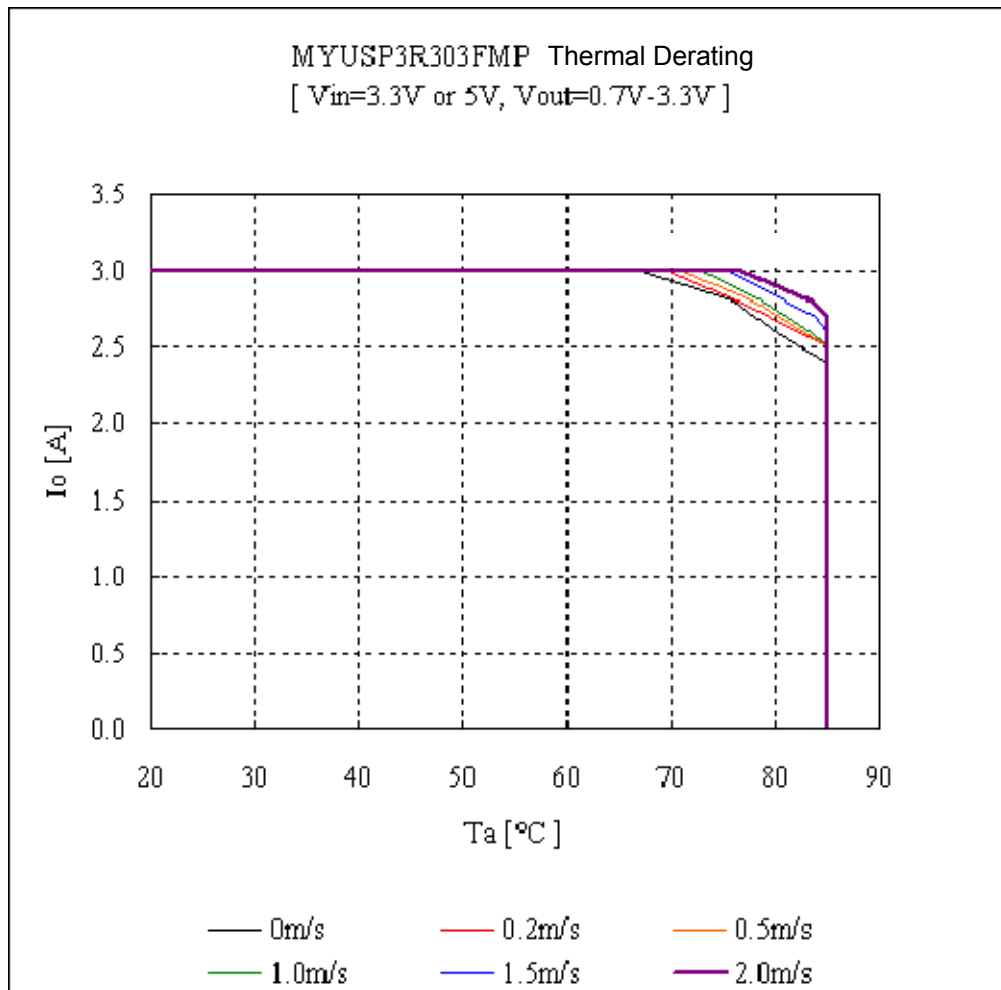

The above derating limits apply to this product soldered directly to 101.6*180mm*1.6mm PCB (double-sided, with 70um copper). Any adjacent parts of high temperature may cause overheating. For reliable operation, please ensure that the IC temperature of this product is maintained below 120°C and the inductor temperature is below 119°C.

⚠ **Note:**

1. This datasheet is downloaded from the website of Murata Manufacturing co., ltd. Therefore, it's specifications are subject to change or our products in it may be discontinued without advance notice. Please check with our sales representatives or product engineers before ordering.
2. This datasheet has only typical specifications because there is no space for detailed specifications. Therefore, please approve our product specifications or transact the approval sheet for product specifications before ordering.

6. Pin Description

6.1. Adjusting the Output Voltage

The output voltage can be adjusted from 0.7V to 3.3V by connecting resistors between TRIM-pin(1Pin) to GND-pin(Pin 3 is recommended for accurate Vout setting).

The following equation gives the required external-resistor values to adjust the output voltage to the required Vout. It is highly recommended that evaluation of the characteristics of this DC-DC converter's operation under your board conditions be thoroughly conducted.

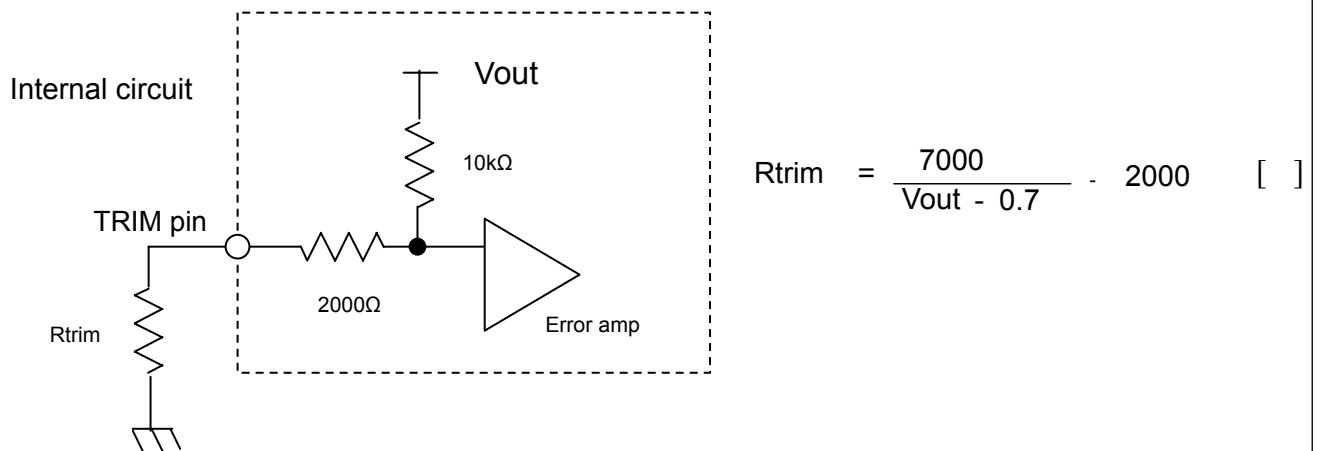

<Rtrim Calculation Example>

Vout(V)	Calculated Rtrim(Ω)	Rtrim Example(Ω)
3.3	692.3	680 + 12
2.5	1888.9	1500 + 390
1.8	4363.6	3900 + 470
1.5	6750	5600 + 1200
1.2	12000	12000
1.0	21333.3	18000 + 3300 + 33
0.8	68000	68000
0.7	∞	Open

6.2. ON/OFF Control

Using the ON/OFF feature, the operation of this product can be disabled without removal of the input voltage. Sequencing of a power supply system and power-saving control can be easily achieved using this function.

When ON/OFF-pin(6pin) is connected to Vin Output Voltage =ON
 When ON/OFF-pin(6pin) is connected to GND Output Voltage =OFF

6.3. Output Voltage Sensing

By connecting SENSE-pin to the load, output voltage drop in wiring shall be compensated.

Please do NOT connect SENSE-pin to the output of LC filter that is set to the Vout line.

When using this way, this product will not operate properly.

< Caution >

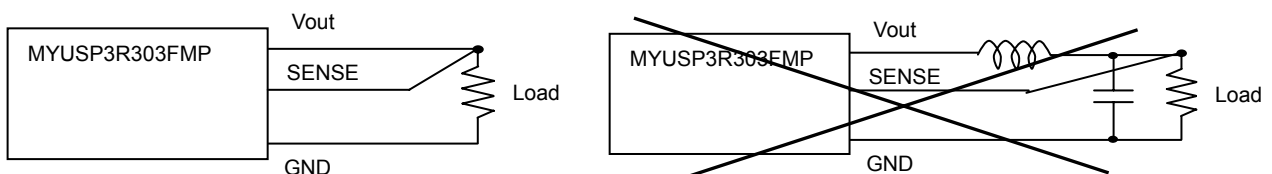

Please connect SENSE-pin to Vout-pin nearby the product, if sense function is not used.

⚠ Note:

1. This datasheet is downloaded from the website of Murata Manufacturing co., ltd. Therefore, it's specifications are subject to change or our products in it may be discontinued without advance notice. Please check with our sales representatives or product engineers before ordering.
2. This datasheet has only typical specifications because there is no space for detailed specifications. Therefore, please approve our product specifications or transact the approval sheet for product specifications before ordering.

6.4. Input External capacitor

It is recommended to connect Ceramic capacitor of 47 μ F or more between Vin terminal(7pin) and GND(5pin). But according to Fig6-4, it can smaller capacity value by a combination of input voltage and output voltage. But smaller input capacitor may leads to an unstable operation of this product caused by input voltage fluctuation. When the impedance of input line is enough small, smaller input capacitor can be applied after checking the stable operation on your product.

Please place the input capacitor as close as possible to this product.

Long wiring between the input capacitor and this product may lead to increased radiation noise and unstable operation of this product.

Fig6-4 Input external capacitor by the combination of input voltage and output voltage.
(When Slew Rate of the output current is less than 1A/ μ s.)

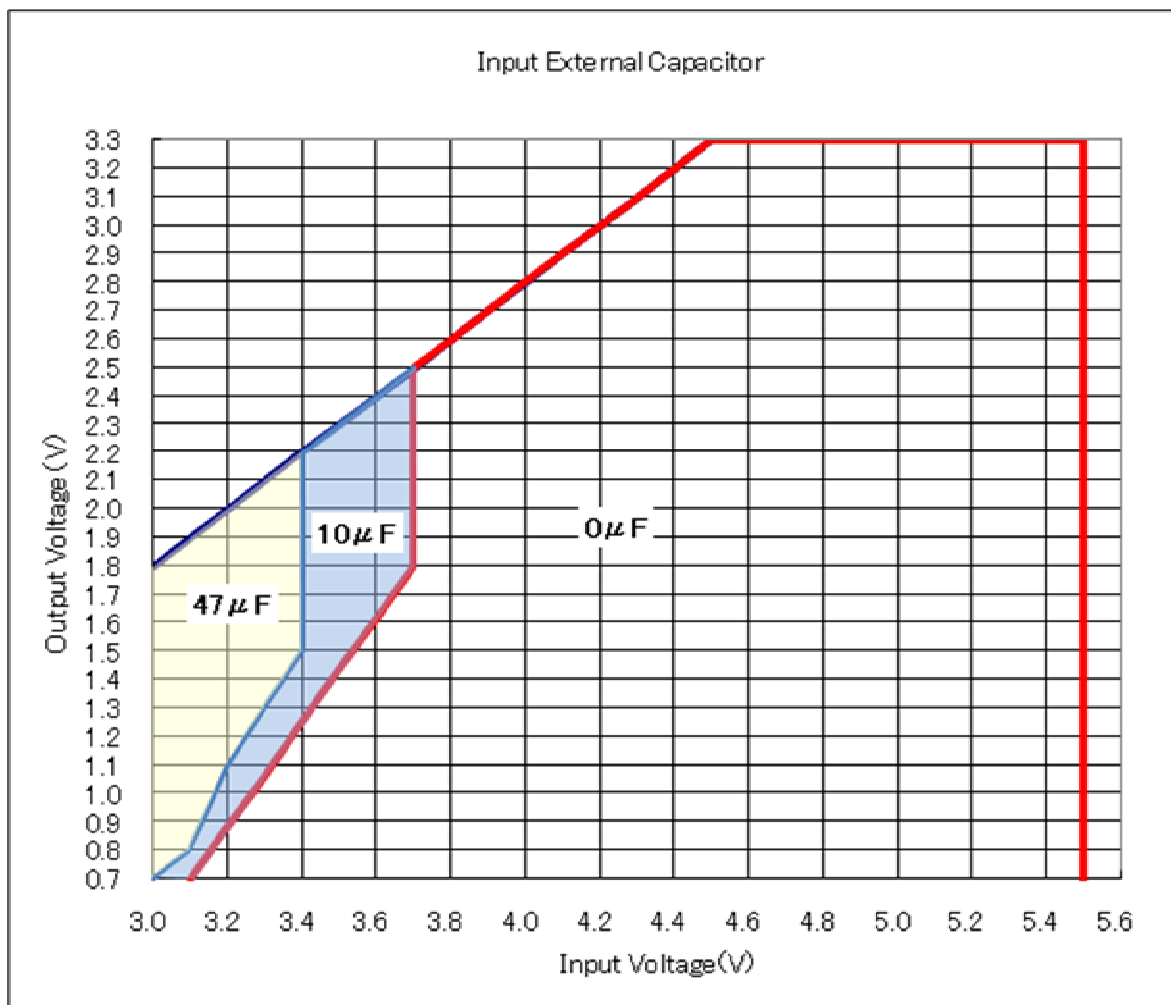

6.5. Output External capacitor

Ceramic capacitors are recommended as output external capacitor. Using ceramic capacitors, small output variation and small ripple voltage are realized.

Output capacitor should be 300 μ F or less. Output capacitor shall be placed near the output terminal.

⚠ Note:

1. This datasheet is downloaded from the website of Murata Manufacturing co., ltd. Therefore, it's specifications are subject to change or our products in it may be discontinued without advance notice. Please check with our sales representatives or product engineers before ordering.
2. This datasheet has only typical specifications because there is no space for detailed specifications. Therefore, please approve our product specifications or transact the approval sheet for product specifications before ordering.

7. Typical Characteristics Data

7.1. Static Electrical Characteristics

$V_{out}=1.0V$

($T_a=25^\circ C$, $C_{in}=GRM32EC80J476K$, $C_{out}=GRM216B11A105K$, $R_{trim}=21333\Omega$)

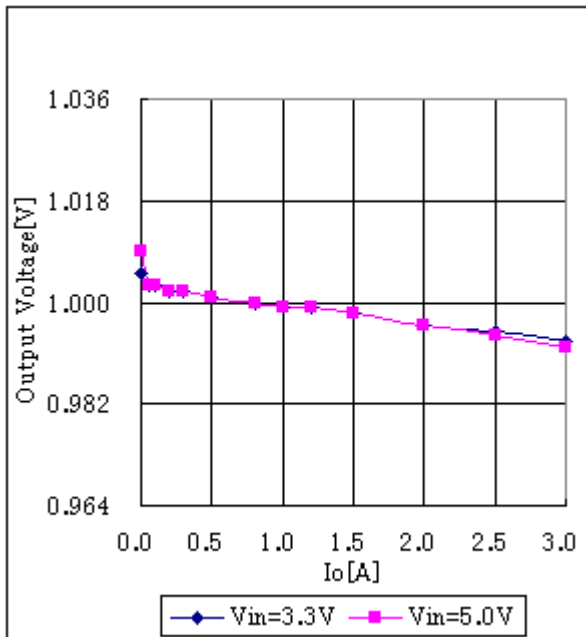

Fig.7-1-1. Output Voltage v.s. Output Current

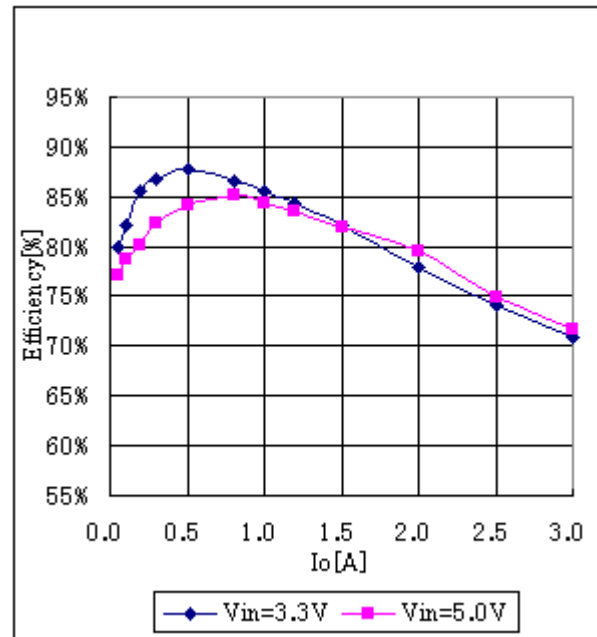

Fig.7-1-2. Efficiency v.s. Output Current

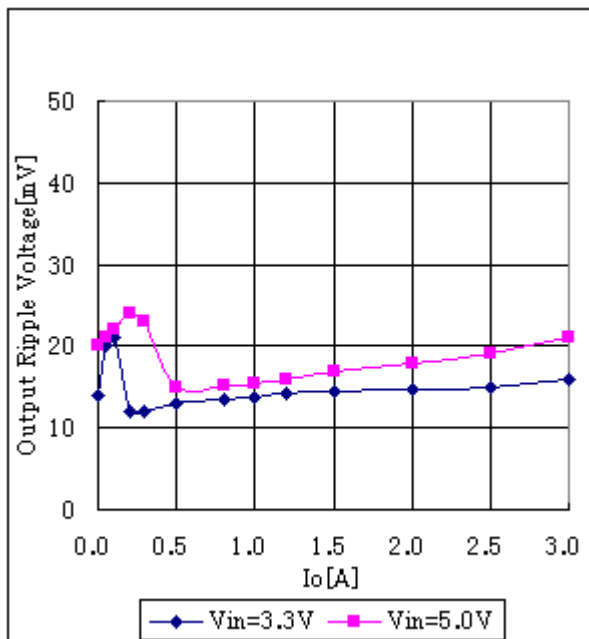

Fig.7-1-3. Ripple Voltage v. s. Output Current

⚠ **Note:**

1. This datasheet is downloaded from the website of Murata Manufacturing co., ltd. Therefore, it's specifications are subject to change or our products in it may be discontinued without advance notice. Please check with our sales representatives or product engineers before ordering.
2. This datasheet has only typical specifications because there is no space for detailed specifications. Therefore, please approve our product specifications or transact the approval sheet for product specifications before ordering.

$V_{out}=1.2V$
 ($T_a=25^{\circ}C$, $C_{in}= GRM32EC80J476K$, $C_{out}= GRM216B11A105K$, $R_{trim}=12000\Omega$)

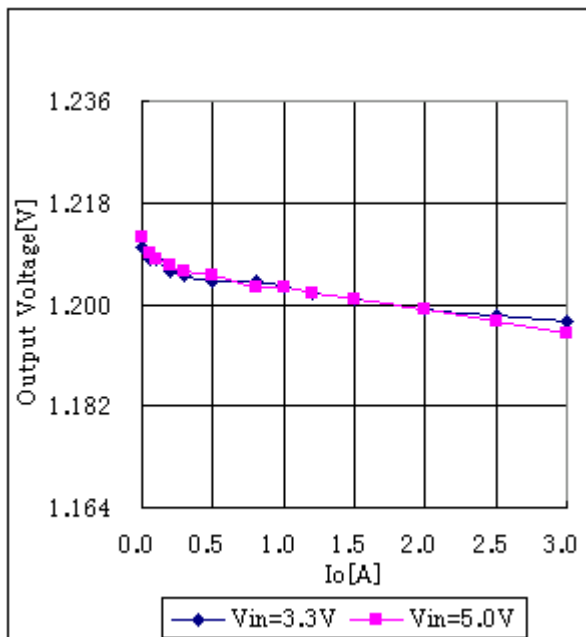

Fig.7-1-4. Output Voltage v.s. Output Current

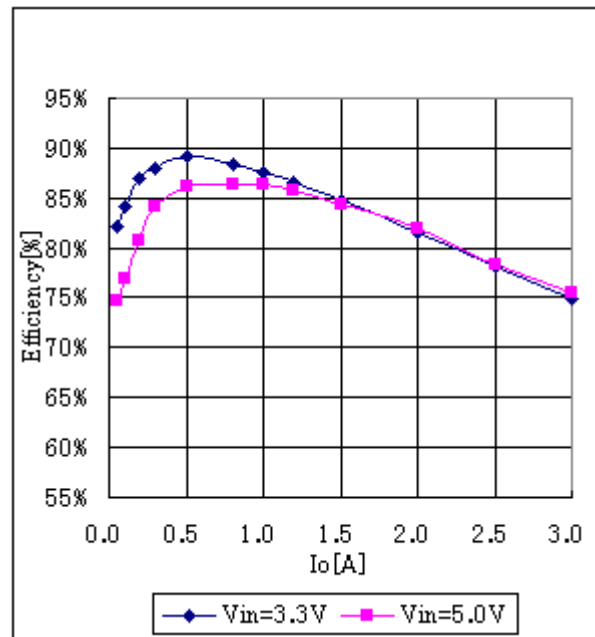

Fig.7-1-5. Efficiency v.s. Output Current

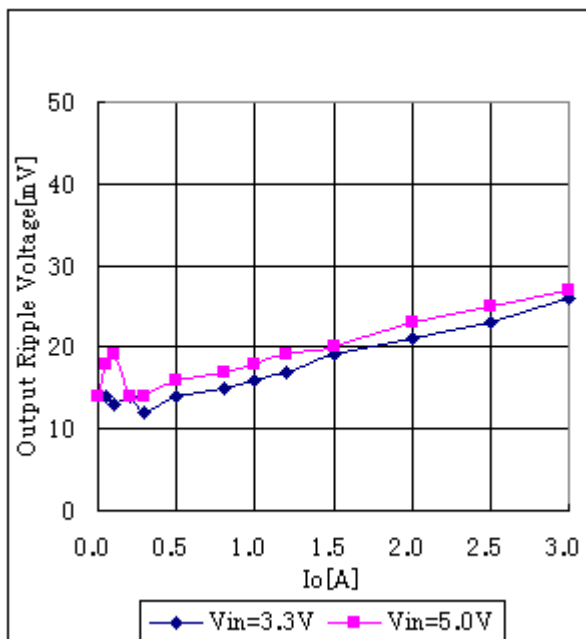

Fig.7-1-6. Ripple Voltage v. s. Output Current

⚠ **Note:**

1. This datasheet is downloaded from the website of Murata Manufacturing co., ltd. Therefore, it's specifications are subject to change or our products in it may be discontinued without advance notice. Please check with our sales representatives or product engineers before ordering.
2. This datasheet has only typical specifications because there is no space for detailed specifications. Therefore, please approve our product specifications or transact the approval sheet for product specifications before ordering.

$V_{out}=1.8V$
 ($T_a=25^{\circ}C$, $C_{in}=GRM32EC80J476K$, $C_{out}=GRM216B11A105K$, $R_{trim}=4370\Omega$)

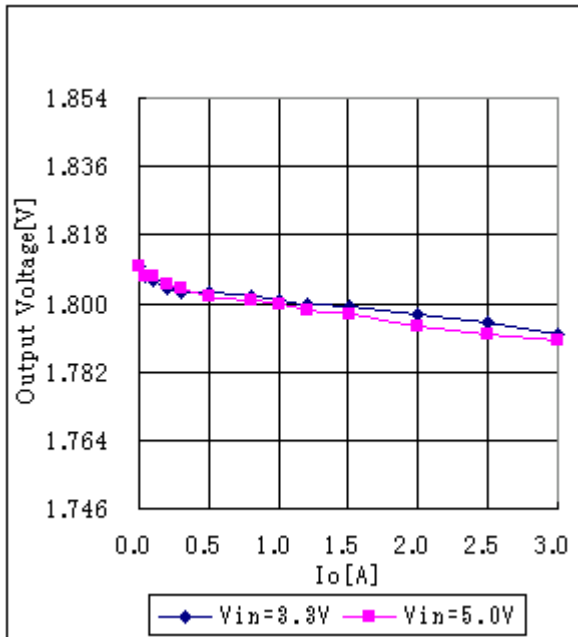

Fig.7-1-7. Output Voltage v.s. Output Current

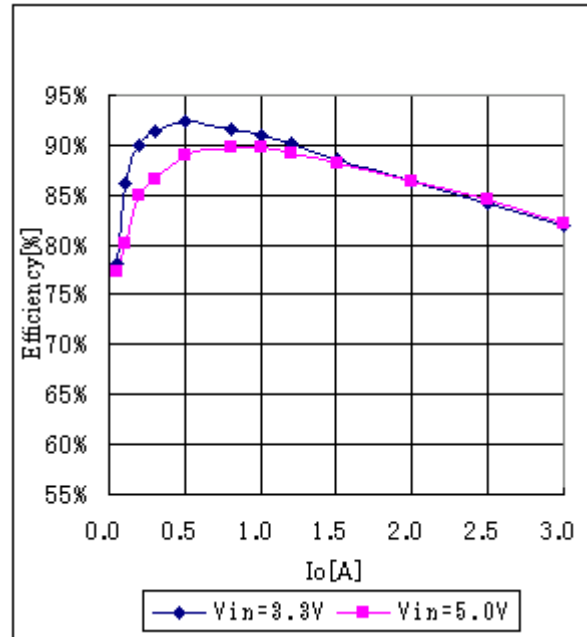

Fig.7-1-8. Efficiency v.s. Output Current

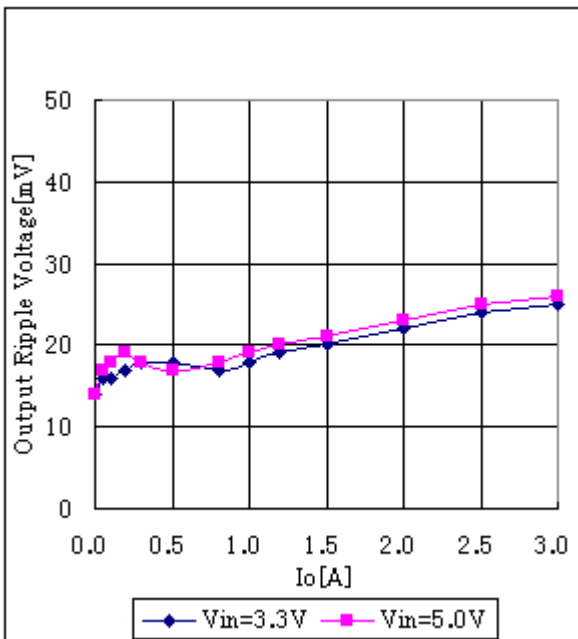

Fig.7-1-9. Ripple Voltage v. s. Output Current

Note:

1. This datasheet is downloaded from the website of Murata Manufacturing co., ltd. Therefore, it's specifications are subject to change or our products in it may be discontinued without advance notice. Please check with our sales representatives or product engineers before ordering.
2. This datasheet has only typical specifications because there is no space for detailed specifications. Therefore, please approve our product specifications or transact the approval sheet for product specifications before ordering.

$V_{out}=3.3V$
 ($T_a=25^\circ C$, $C_{in}=GRM32EC80J476K$, $C_{out}=GRM216B11A105K$, $R_{trim}=692\Omega$)

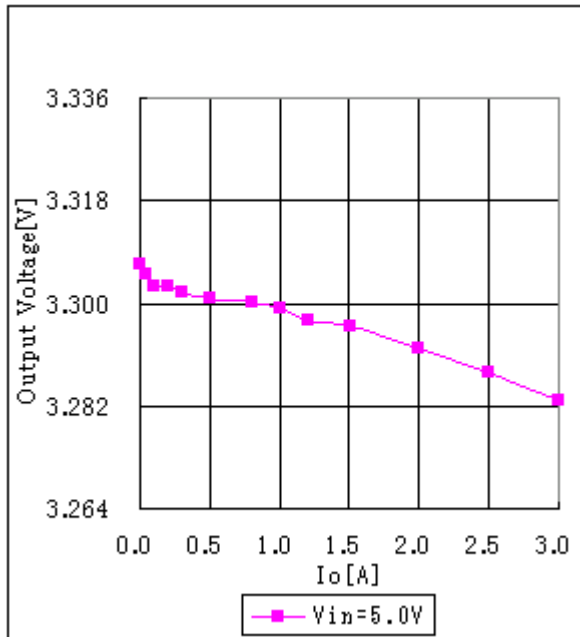

Fig.7-1-10. Output Voltage v.s. Output Current

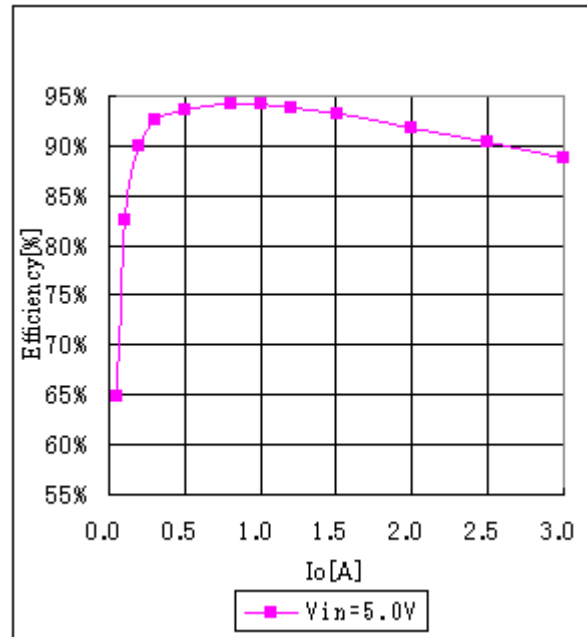

Fig.7-1-11. Efficiency v.s. Output Current

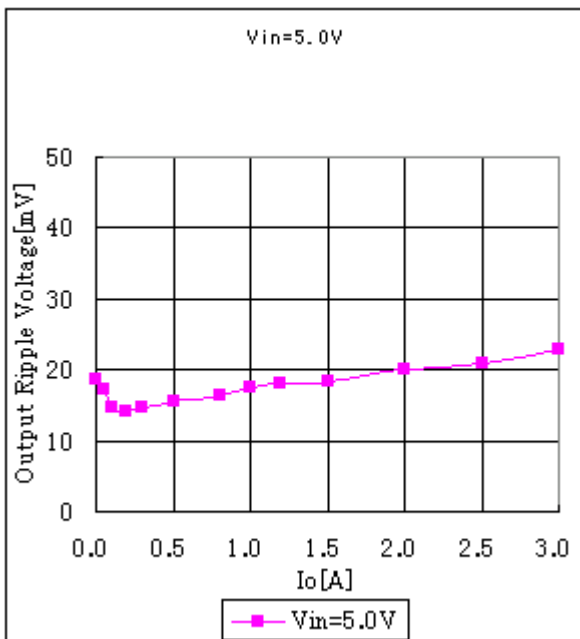

Fig.7-1-12. Ripple Voltage v. s. Output Current

⚠ **Note:**

1. This datasheet is downloaded from the website of Murata Manufacturing co., ltd. Therefore, it's specifications are subject to change or our products in it may be discontinued without advance notice. Please check with our sales representatives or product engineers before ordering.
2. This datasheet has only typical specifications because there is no space for detailed specifications. Therefore, please approve our product specifications or transact the approval sheet for product specifications before ordering.

7.2. Dynamic Electrical Characteristics

$V_{in}=3.3V$, $V_{out}=1.2V$
 ($T_a=25^{\circ}C$, $C_{in}=GRM32EC80J476K$, $C_{out}=GRM216B11A105K$, $R_{trim}=12000\Omega$)

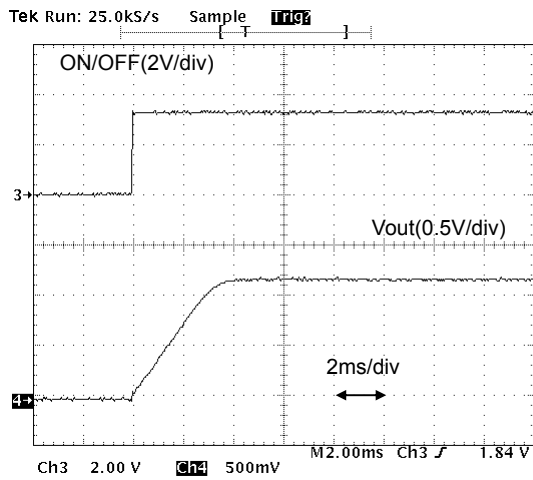

Fig.7-2-1. Start-up Waveform ($I_o=0A$)

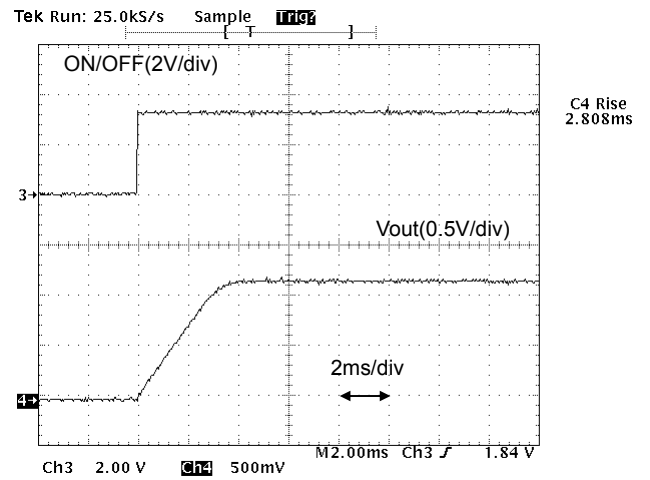

Fig.7-2-2. Start-up Waveform ($I_o=3A$)

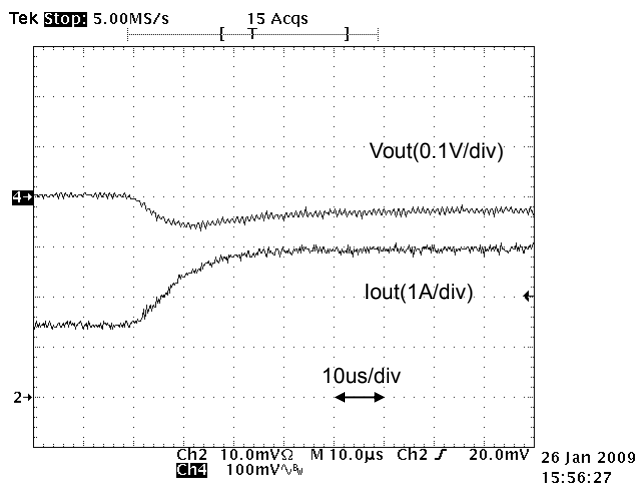

Fig.7-2-3. Load Transient Response ($I_o=1.5\rightarrow 3A$)

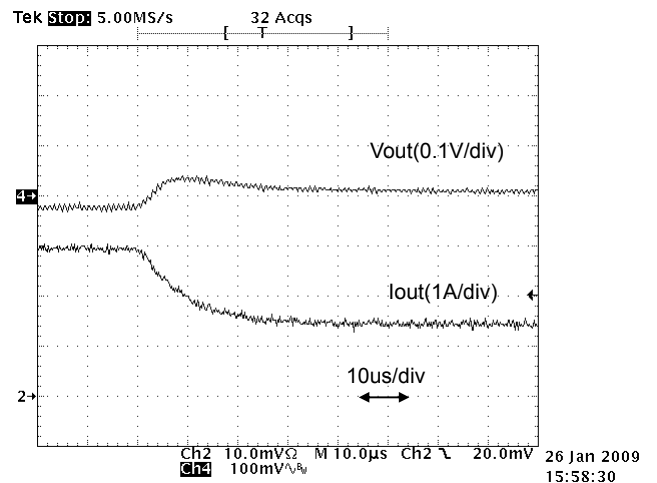

Fig.7-2-4. Load Transient Response ($I_o=3\rightarrow 1.5A$)

Note:

1. This datasheet is downloaded from the website of Murata Manufacturing co., ltd. Therefore, it's specifications are subject to change or our products in it may be discontinued without advance notice. Please check with our sales representatives or product engineers before ordering.
2. This datasheet has only typical specifications because there is no space for detailed specifications. Therefore, please approve our product specifications or transact the approval sheet for product specifications before ordering.

$V_{in}=5.0V$, $V_{out}=1.2V$
 ($T_a=25^{\circ}C$, $C_{in}=GRM32EC80J476K$, $C_{out}=GRM216B11A105K$, $R_{trim}=12000\Omega$)

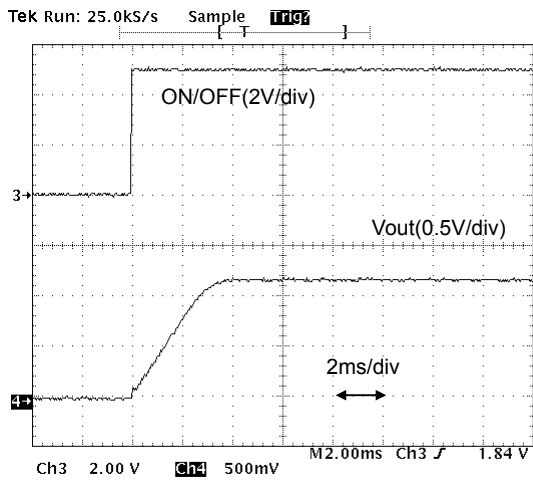

Fig.7-2-1. Start-up Waveform ($I_o=0A$)

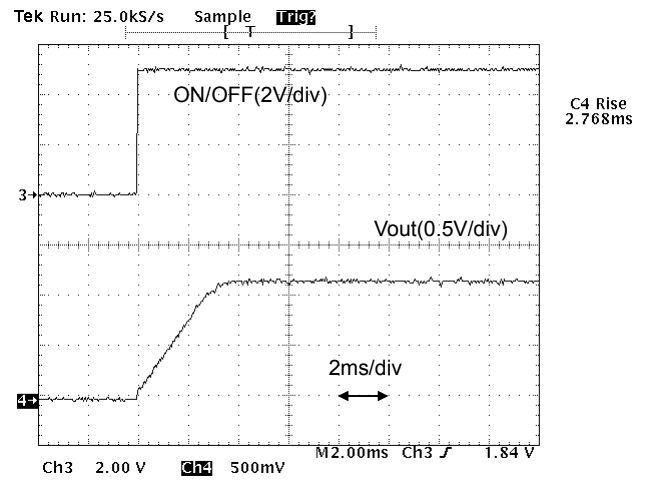

Fig.7-2-2. Start-up Waveform ($I_o=3A$)

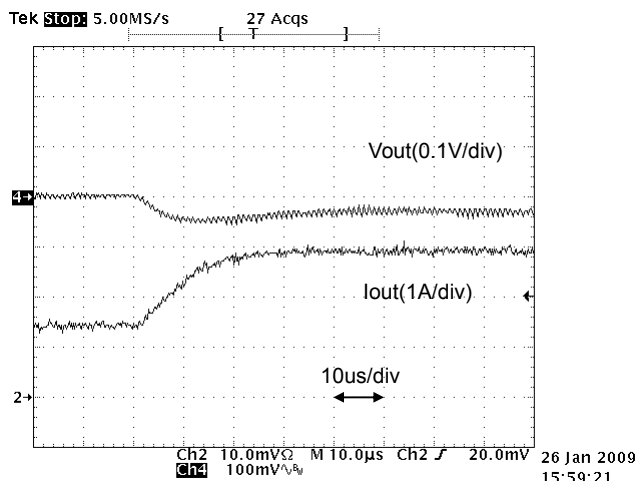

Fig.7-2-3. Load Transient Response ($I_o=1.5\rightarrow 3A$)

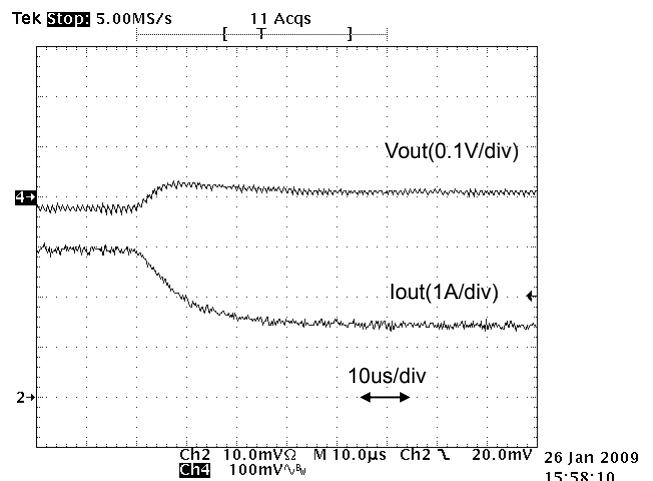

Fig.7-2-4. Load Transient Response ($I_o=3\rightarrow 1.5A$)

Note:

1. This datasheet is downloaded from the website of Murata Manufacturing co., ltd. Therefore, it's specifications are subject to change or our products in it may be discontinued without advance notice. Please check with our sales representatives or product engineers before ordering.
2. This datasheet has only typical specifications because there is no space for detailed specifications. Therefore, please approve our product specifications or transact the approval sheet for product specifications before ordering.

8. Mounting Condition

8. 1 PCB Land Pattern Recommendation

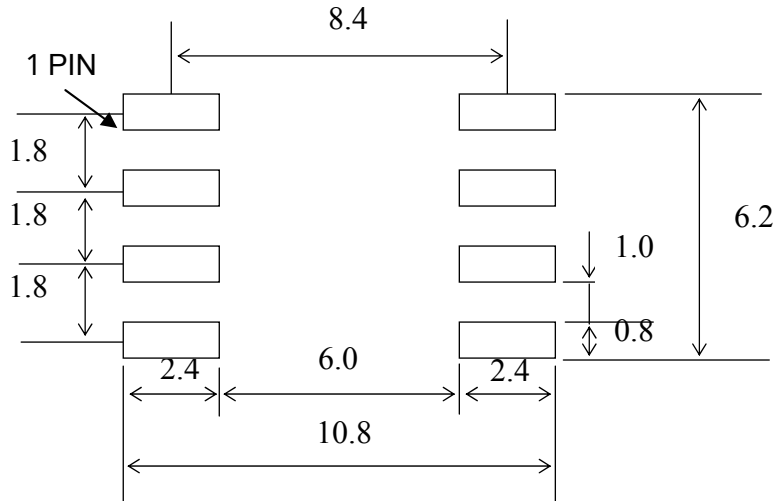

8. 2 Recommended Soldering Conditions

Reflow Soldering

This product is RoHS compliant. The following profile is recommended for the reflow of this product using Pb-free solder paste (Sn-Ag-Cu).

Method : Full convection reflow soldering

Profile details

Soldering temperature : 245°C+0/-5°C
 Soldering time : 20 to 60 seconds, over 220°C
 Preheating : 60 to 150 seconds, 150 to 200°C
 Programming rate : 3°C/ sec. Max., 217 to 245°C
 Times : 1 time

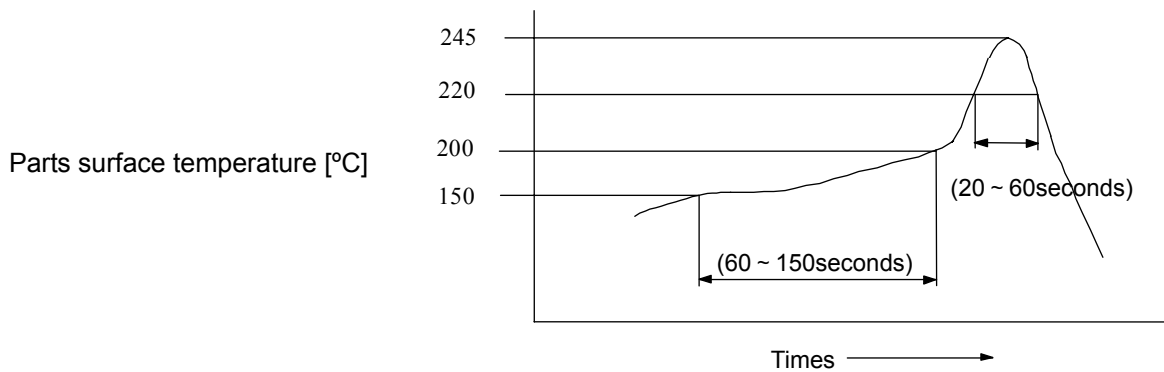

Do not vibrate for the products on reflow.

Please need to take care temperature control because mounted parts may come off if the product are left under the high temperature.

Do not reflow DC-DC converter as follows, because DC-DC converter may fall down from a substrate during reflowing.

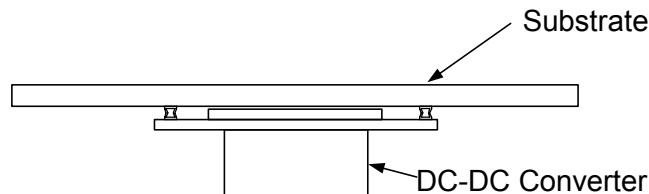

⚠ Note:

1. This datasheet is downloaded from the website of Murata Manufacturing co., ltd. Therefore, it's specifications are subject to change or our products in it may be discontinued without advance notice. Please check with our sales representatives or product engineers before ordering.
2. This datasheet has only typical specifications because there is no space for detailed specifications. Therefore, please approve our product specifications or transact the approval sheet for product specifications before ordering.

9. Notice

PCB Design

Both input-side and output side, please make the wiring loop between plus and minus as small as possible. The influence of a leakage inductance can be reduced.
 Please place Rtrim (resistor for output voltage setting) such as it connects 1pin and 3pin.
 Please make the power line pattern as wide and short as possible.
 The Following figure is an example of recommendable PCB design.

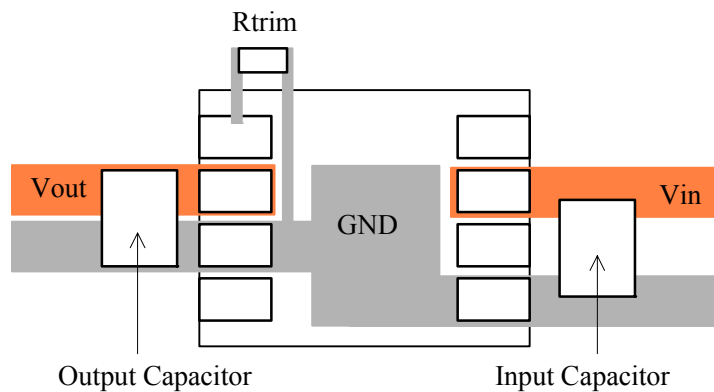

This product should not be operated in parallel or in series.

Please do not use a connector or a socket to connect this product to your product. The electric characteristics may be deteriorated by the influence of contact resistance.

Be sure to provide an appropriate fail-safe function on your product to prevent secondary damage that may be caused due to abnormal functional or failure of this product.

Inrush current protection is not a feature of this product.

Please connect the input terminals with the correct polarity. If an error in polarity connection is made this product may be damaged. If this product is damaged internally, an elevated input current may flow, and so this product may exhibit an abnormal temperature rise, or your product may be damaged. Please add a diode and fuse per the following diagram to protect them.

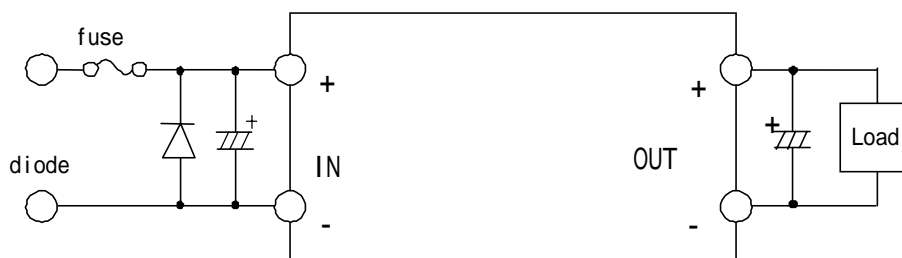

Please select diode and fuse after confirming the operation of your product.

⚠ Note:

1. This datasheet is downloaded from the website of Murata Manufacturing co., ltd. Therefore, it's specifications are subject to change or our products in it may be discontinued without advance notice. Please check with our sales representatives or product engineers before ordering.
2. This datasheet has only typical specifications because there is no space for detailed specifications. Therefore, please approve our product specifications or transact the approval sheet for product specifications before ordering.

**Note**

. Please contact our main sales office or nearby sales office before using our products for the applications listed below which require especially high reliability for the prevention of defects which might directly cause damage to the third party's life, body or property or this products for any other applications that described in the above.

Aircraft equipment
Aerospace equipment
Undersea equipment
Power plant control equipment
Medical equipment
Transportation equipment (vehicles, trains, ships, etc.)
Traffic signal equipment
Disaster prevention /crime prevention equipment
Data-processing equipment
Application of similar complexity and/or reliability requirements to the applications listed in the above.

2. This catalog is indicated in March 2009. About the written contents, since changing without a preliminary announcement for improvement and supply are sometimes stopped, please confirm in case of ordering. If written contents are unknown, please ask to our main sales office or nearby sales office.
3. Types and specification in this catalog are referenced for your information only. Please confirm detailed specifications by approving our individual drawing and specification sheet.

⚠ Note:

1. This datasheet is downloaded from the website of Murata Manufacturing co., ltd. Therefore, it's specifications are subject to change or our products in it may be discontinued without advance notice. Please check with our sales representatives or product engineers before ordering.
2. This datasheet has only typical specifications because there is no space for detailed specifications. Therefore, please approve our product specifications or transact the approval sheet for product specifications before ordering.