

# DC-DC Converter Short Form

## MPDRX021S (Ultra High Speed Response POL)

### Features

- Ultra High Speed Response
- Input range (4.5V to 5.5V), Wide output range ( 0.85V to 1.8V )
- 10A Output Current
- Wide operational temperature ( -40°C to +85°C )
- ON/OFF / Tracking / Output voltage sense / Over current function / Over temperature function



### GENERAL SPECIFICATIONS (Ta=25°C)

Item	Symbol	Condition	MIN.	TYP.	MAX.	UNIT
Input Voltage	Vin		4.5	5.0	5.5	V
Output Voltage Adjustable Range	Vout		0.85		1.8	V
Output Voltage tolerance	Vo tol	Over Io, Temperature range Vin=4.5~5.5V	Vo=0.85 ~ 1.2V	-1.5	+1.5	%
			Vo=1.2 ~ 1.8V	-2.0	+2.0	
Output Current	Iout		0	-	10	A
Ripple Voltage	Vrpl	Vin=5V, Vout=1.2V, Iout=10A, BW=20MHz	-	10	-	mVpp
Efficiency	EFF	Vin=5V, Vout=1.2V, Iout=10A	-	87	-	%

### DIMENSIONS

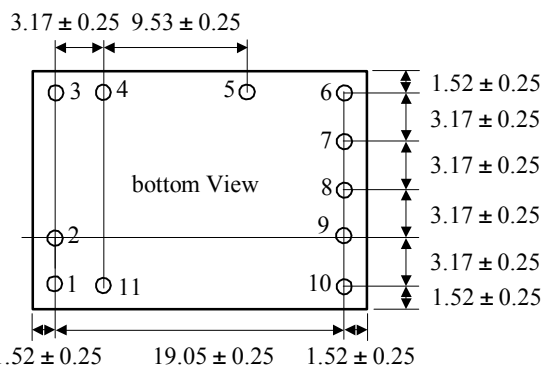
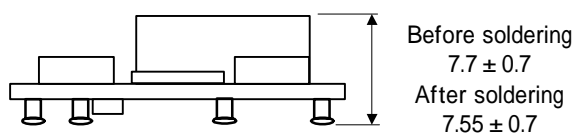
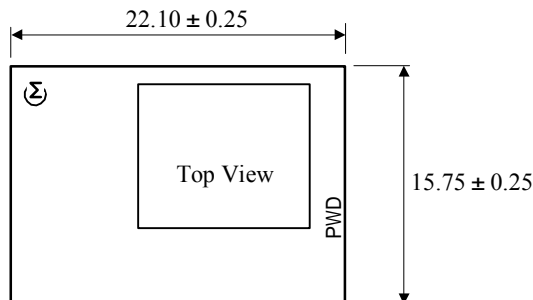

Pin No.	Symbol	Function
2	Vin	Input voltage
3,4	GND	GND
5	Vout	Output Voltage
6	+SENSE	Output voltage +sense
7	-SENSE	Output voltage -sense
8	Vout Adjust	Output Voltage Adjustment
10	Track	Tracking Function
11	ON/OFF	Remote ON/OFF Control

Tolerance is not accumulated  
[unit : mm]

#### △ Note:

1. This datasheet is downloaded from the website of Murata Manufacturing co., ltd. Therefore, it's specifications are subject to change or our products in it may be discontinued without advance notice. Please check with our sales representatives or product engineers before ordering.
2. This datasheet has only typical specifications because there is no space for detailed specifications. Therefore, please approve our product specifications or transact the approval sheet for product specifications before ordering.

## OUTPUT VOLTAGE ADJUSTMENT

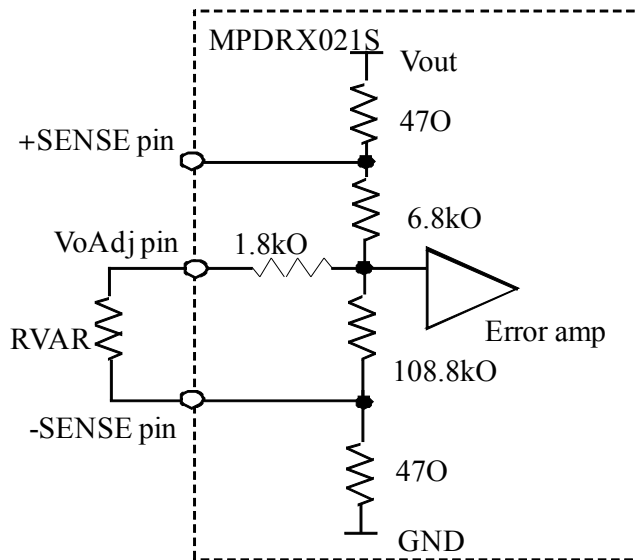

$$RVAR = \frac{5440}{V_{out}[V] - 0.85[V]} - 1800[\text{ohm}]$$

## &lt;RVAR CALCULATION EXAMPLE&gt;

Vout(V)	Calculated RVAR(Ω)	RVAR Example(Ω)
1.8	3926	3.9k + 27
1.5	6569	6.3k + 270
1.2	13743	13k + 750
1.0	34467	33k + 1.5k
0.7	∞	Open

## TEST CIRCUIT

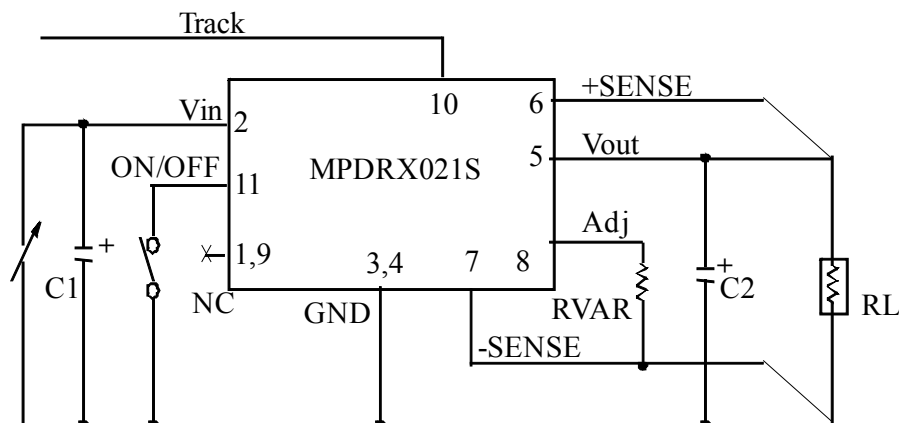

- C1 : 300 $\mu$ F / 8V Low ESR tantalum Capacitor  
ex.) Panasonic: EEFUE01J151R(150 $\mu$ F/8V)  $\times$ 2
- C2 : 1000 $\mu$ F / 4V Low ESR tantalum Capacitor  
ex.) Kemet: T530X108M4AE6(1000 $\mu$ F/4V)

Please make sure to place C1 and C2 nearby input and output terminal of DC-DC converter.

## ⚠ Note:

1. This datasheet is downloaded from the website of Murata Manufacturing co., ltd. Therefore, it's specifications are subject to change or our products in it may be discontinued without advance notice. Please check with our sales representatives or product engineers before ordering.
2. This datasheet has only typical specifications because there is no space for detailed specifications. Therefore, please approve our product specifications or transact the approval sheet for product specifications before ordering.

## THERMAL DERATING

Vin=4.5~5.5V

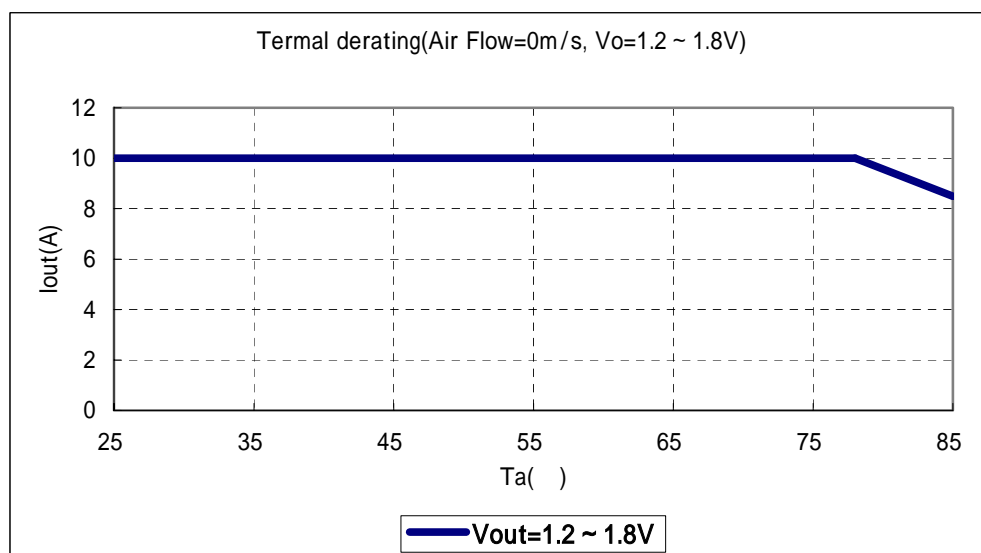
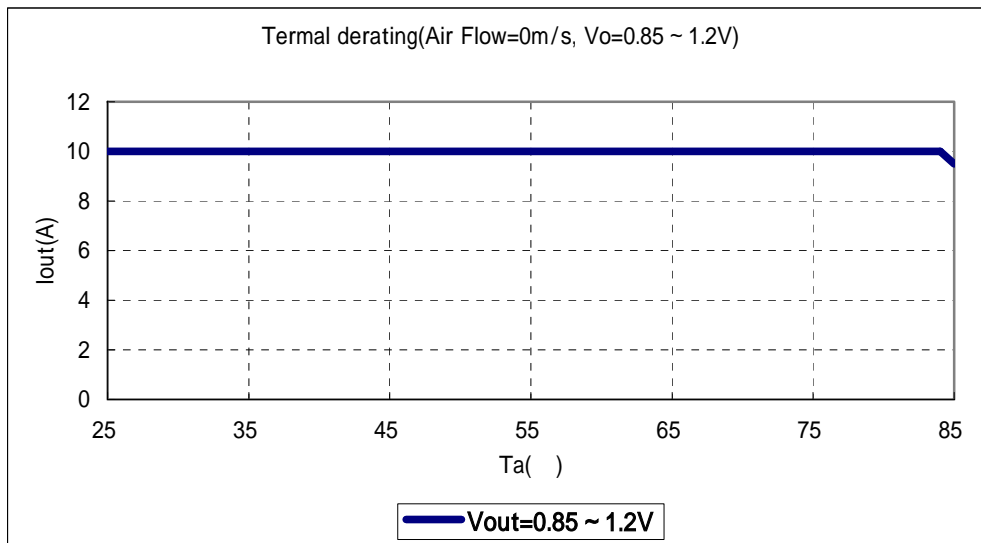

The above derating limits apply to this product soldered directly to 101.6\*180mm\*1.6mm PCB. Any adjacent parts of high temperature may cause overheating. For reliable operation, please ensure that the FET temperature of this product is maintained below 120°C and the inductor temperature is below 106°C.

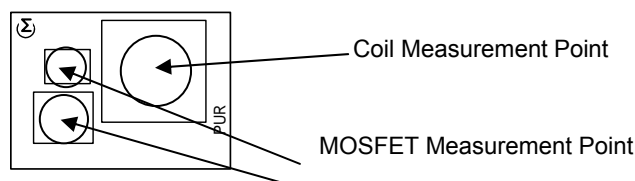

⚠ **Note:**

1. This datasheet is downloaded from the website of Murata Manufacturing co., ltd. Therefore, it's specifications are subject to change or our products in it may be discontinued without advance notice. Please check with our sales representatives or product engineers before ordering.
2. This datasheet has only typical specifications because there is no space for detailed specifications. Therefore, please approve our product specifications or transact the approval sheet for product specifications before ordering.

## GENERAL CHARACTERISTICS (Ta=25°C)

Vou=1.1V

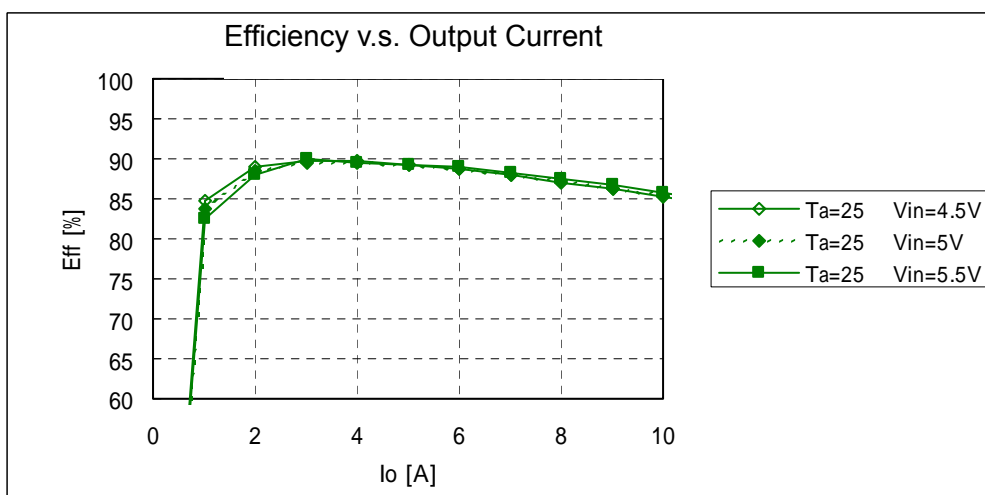
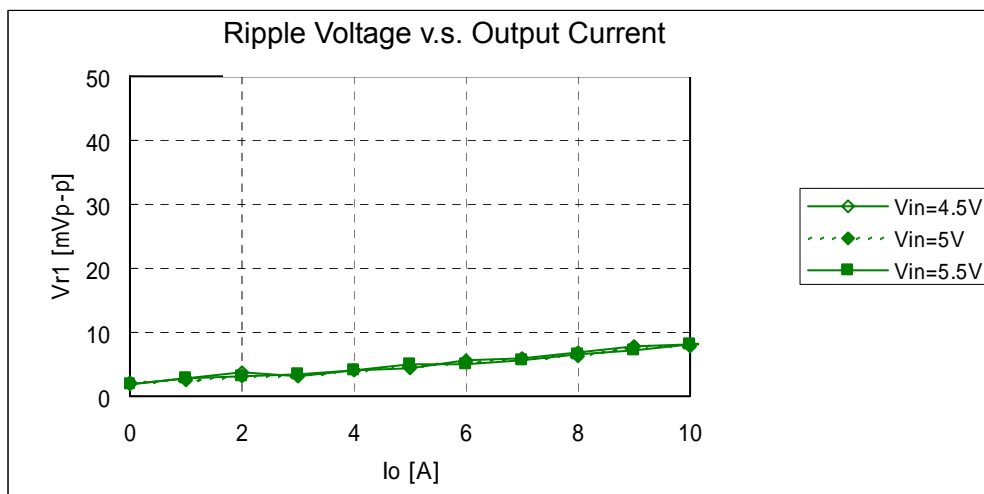
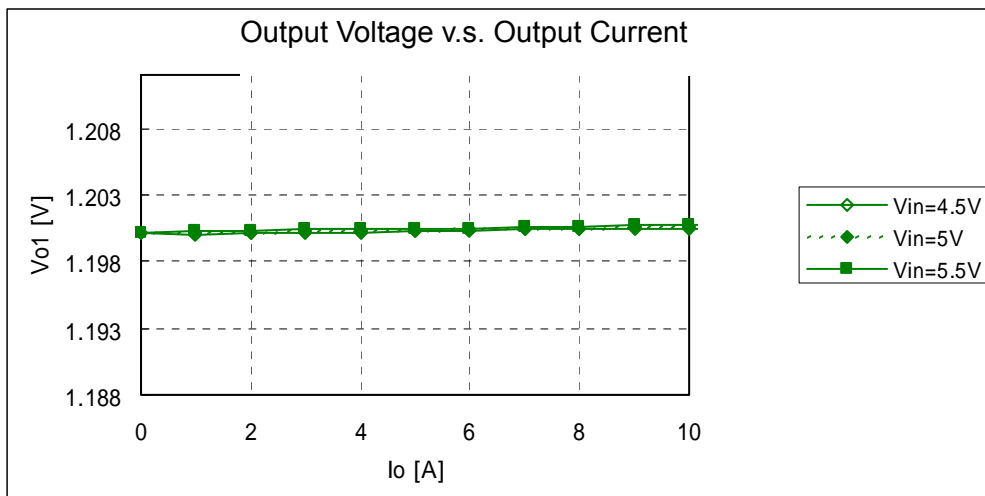

## ⚠ Note:

1. This datasheet is downloaded from the website of Murata Manufacturing co., ltd. Therefore, it's specifications are subject to change or our products in it may be discontinued without advance notice. Please check with our sales representatives or product engineers before ordering.
2. This datasheet has only typical specifications because there is no space for detailed specifications. Therefore, please approve our product specifications or transact the approval sheet for product specifications before ordering.