

Isolated DC-DC Converter Specification

1. Application

This specification applies to the Isolated DC-DC Converters,
MPD6D10_S Series.

(Nominal wattage 10W Series.)

2. Murata Part Number

MPD6D101S

MPD6D102S

MPD6D103S

MPD6D104S

MPD6D105S

MPD6D106S

MPD6D107S

MPD6D108S

MPD6D109S

3. Appearance and Dimensions

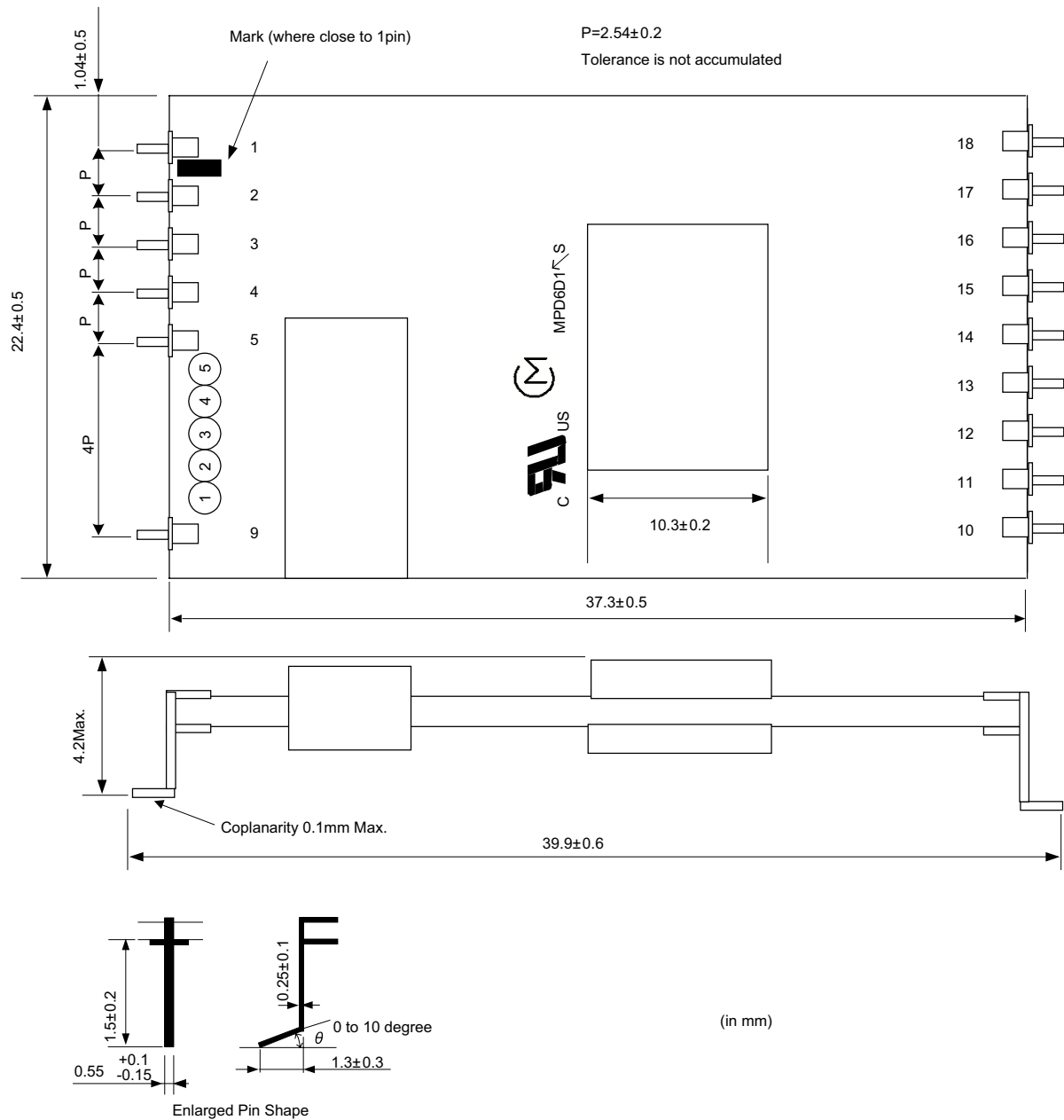

Marking

- | | |
|----------------|--|
| Part Number | MPD6D10_S |
| Murata CM Mark | |
| Lot Number | ① Factory Symbol |
| | ② The last number of production year. Example: 2 stands for 2002 |
| | ③ Production month. Example: 1 stands for January |
| | ⋮ |
| | 9 stands for September |
| | O stands for October |
| | N stands for November |
| | D stands for December |
| | ④ 01,02,03,04,05,06,07,08,09 which is __ of MPD6D1__S |
| | ⑤ |
| | ⑥ Revision (No first edition) |

4. Pin Number and Function

Pin No	Pin Symbol	Function
9,10	NCo	Mechanical supplemental contact pins. Pins on one side of printed circuit board. To contact DC-DC Converter mounted board with thermal setting resin.
1	+Vout	(+) Output
2	+Vout	(+) Output
3	+Vout	(+) Output
4	-Vout	(-) Output
5	-Vout	(-) Output
11	ALM	Alarm Output
12	RC	Remote On/Off Control
13	PO	Parallel Operation
14	NC	-
15	+Vin	(+) Input
16	+Vin	(+) Input
17	-Vin	(-) Input
18	-Vin	(-) Input

5. Block Diagram
Entire Product

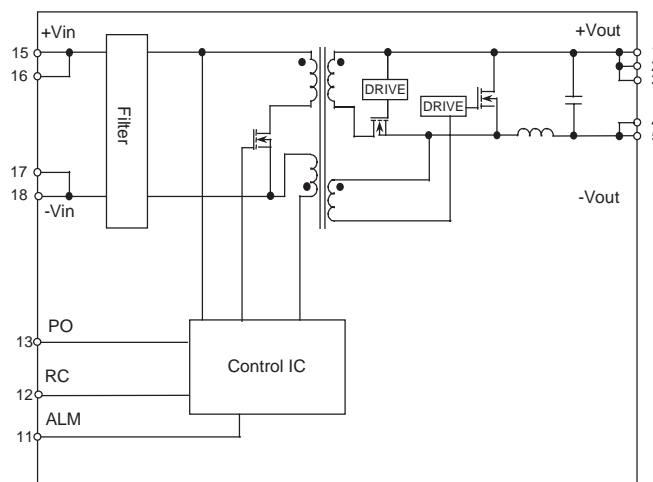

6. Environmental Conditions

Ambient Temperature	: -40 to +85 degreeC
Ambient Humidity	: 20 to 85%RH (No condensation)
Storage Temperature	: -45 to +90 degreeC
Storage Humidity	: 10 to 95%RH (No condensation)

7. Absolute Maximum Ratings

Items	Unit	Maximum	Remark	
Minimum Input Voltage	V	0		
Maximum Input Voltage	Time	Continuous	Slew Rate: 42V/10us	
RC Pin Voltage		V		75
ALM Pin Voltage		V		90
PO Pin Voltage	V	8		
ALM Pin Maximum Sink Current	mA	10		

8. Characteristics

8-1 Electrical Characteristics

8-1-1 General Characteristics (Static, Ambient temperature: Ta=-40 to +85 degreeC)

Items	Unit	Value	Remark
Rated Input Voltage	V	48	
Input Voltage Range	V	36 to 60	No power derating with 0.2m/s (40LFM)
		36 to 75	No power derating with 0.5m/s (100LFM)
		36 to 75	Power derating with 0m/s (0LFM)
Turn-on Input Voltage	V	32.0 to 36.0	
Hysteresis Voltage	V	Minimum 2	Input voltage difference between turn-on/turn-off
Galvanic Isolation Voltage	Vdc	Minimum 1,500	For one minute between input and output
EMC (Radiated EMI / Conduction)		In accordance with CISPR Publication22, Class A (VCCI Class A)	
Safety Standards		UL60950(UL / C-UL)	Recognized
CE Marking		Attached	Self-declaration

8-1-2 Output Characteristics Ta=-40 to 85 degreeC

Items	Models	MPD6D10_S									Unit
		101	102	103	104	105	106	107	108	109	
Nominal Output Voltage		12.0	1.2	1.5	1.8	2.0	2.5	3.3	5.0	5.2	V
Output Voltage Regulation Vin=36 to 75V Output current range = 0 to 100%		+5%, -3%									%
Nominal Output Current		0.8	3.5	3.5	3.0	3.0	3.0	3.0	2.0	2.0	A
Output Current-limit Inception	Min.	0.82	3.60	3.60	3.10	3.10	3.10	3.10	2.06	2.06	A
Over Voltage Protection Note 1	Min.	14.4	1.44	1.80	2.16	2.40	3.00	3.96	6.00	6.24	V
Low Voltage Protection Note 2	Max.	10.8	1.08	1.35	1.62	1.80	2.25	2.97	4.50	4.68	V
Efficiency (Typ.) Ta=25°C, Vin=48V, Nominal Output Current		88	79	82	86	86	88	89	89	89	%
Output Ripple and Noise	Max. Note 3	50								100	mVp-p
Output Ripple	Max. Note 3	25								50	mVp-p

Note 1: Output is halted in latch-up mode after a mask time of 0.5ms (Typ.), preventing DC-DC Converter malfunction by external noise and/or transient output voltage change.

Note 2: Output is halted in latch-up mode after a mask time of 500ms (Typ.), preventing DC-DC Converter from malfunction by external noise and/or transient output current change.

Note 3: Refer to section 10. Measurement Setup.

8-1-3 Typical Power Derating

Nominal output current is attainable with 0.5m/s (100LFM), Vin=36 to 75V or 0.2m/s (40LFM), Vin=36 to 60V.
 Power derating is required under 0m/s (0LFM), Vin=36 to 75V.

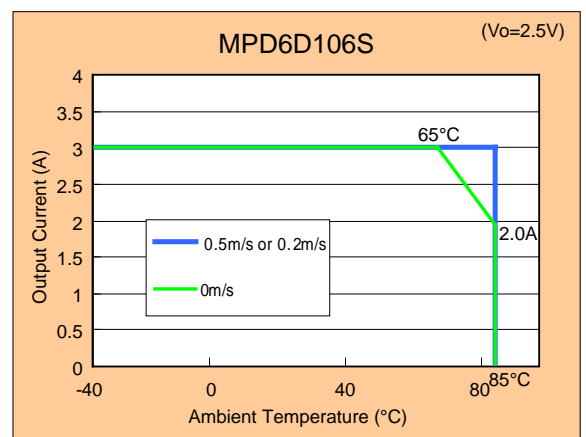
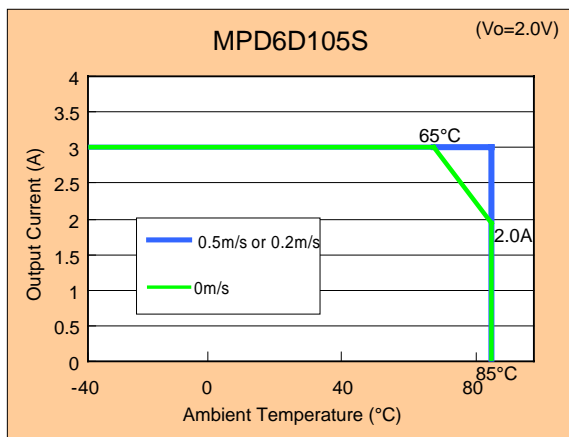
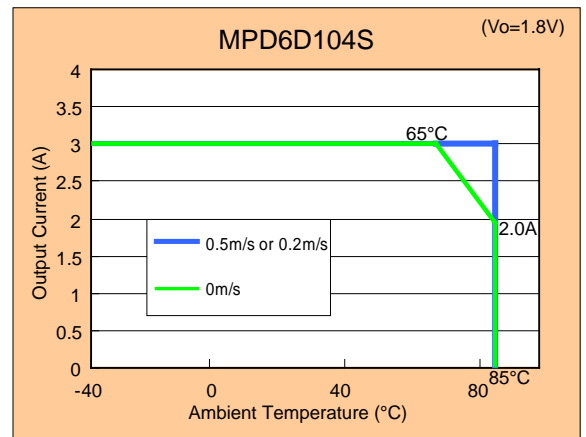
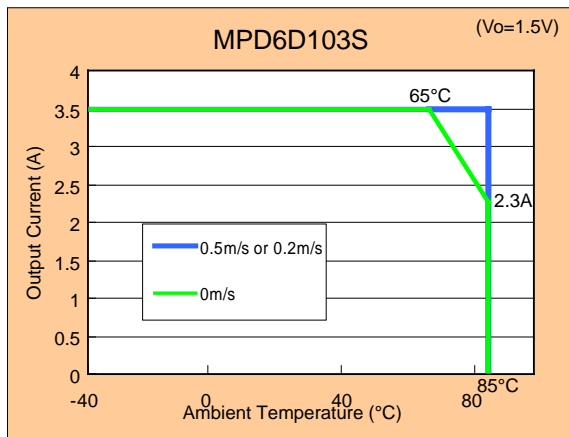
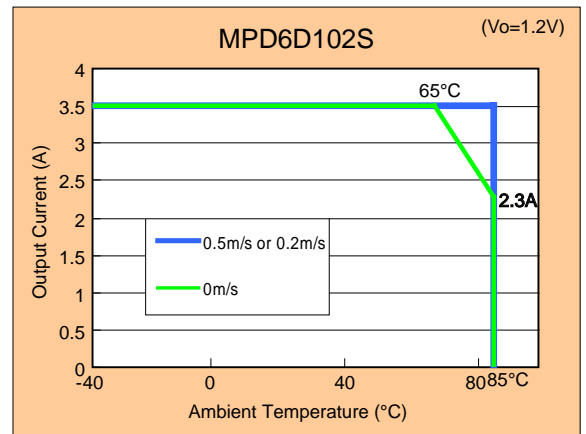
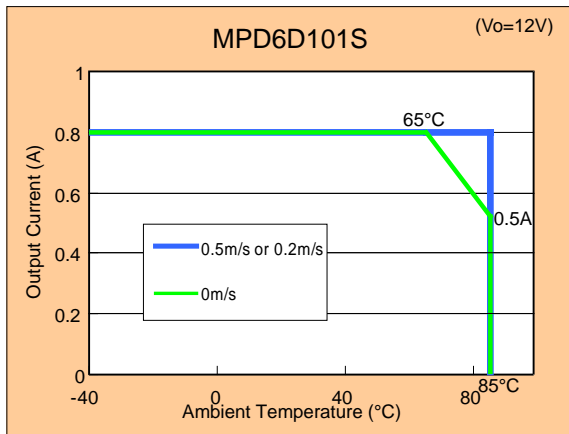

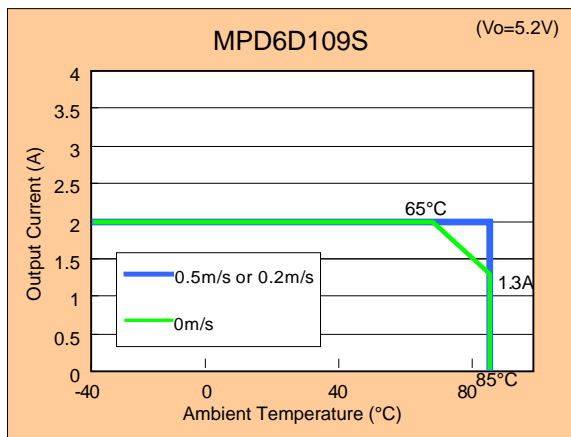
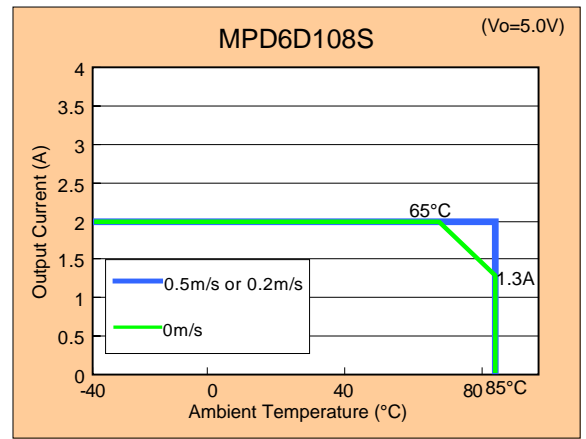
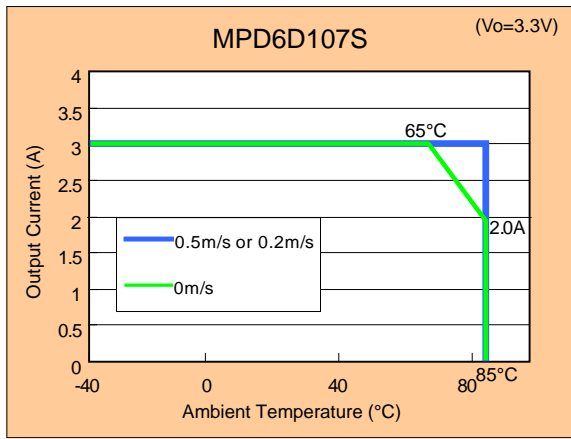

8-2 Operation Information

8-2-1 Reset Condition

In order to reset all function, the input voltage (Vin) must be set under 5V for 1s. min.

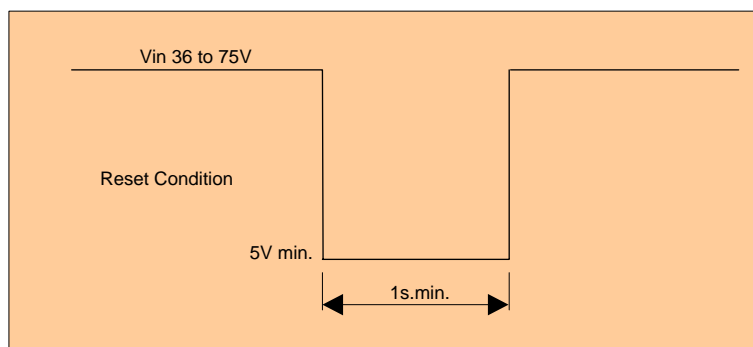

8-2-2 Over Voltage Protection (OVP)

The Isolated DC-DC Converter enters latch-up mode after a typical 0.5ms. mask time, when the output voltage is over the value specified in Over Voltage

Protection (Section 8-1-2) by failure of internal control circuit.

In order to reset, the input voltage must be set under 5V for 1s. min.

Output voltage might exceed the point at which OVP starts to function under the specific conditions of transient input voltage or output current changes.

Therefore, OVP is set to wait for the mask time 0.5ms.

It is recommended to evaluate your equipment installed with the DC-DC Converter.

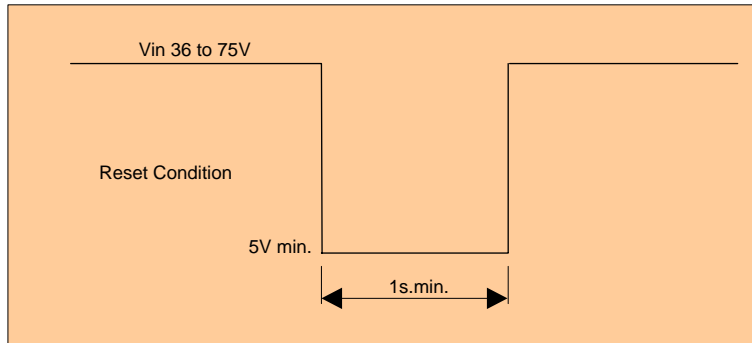

8-2-3 Low Voltage Protection (LVP)

The Isolated DC-DC Converter enters latch-up mode after typical 500ms. mask time, when the output voltage is under the value specified in Low Voltage

Protection (Section8-1-2) by operating Over Current-Limit Inception due to failure of internal control or overload.

In order to reset, the input voltage must be set under 5V for 1s. min.

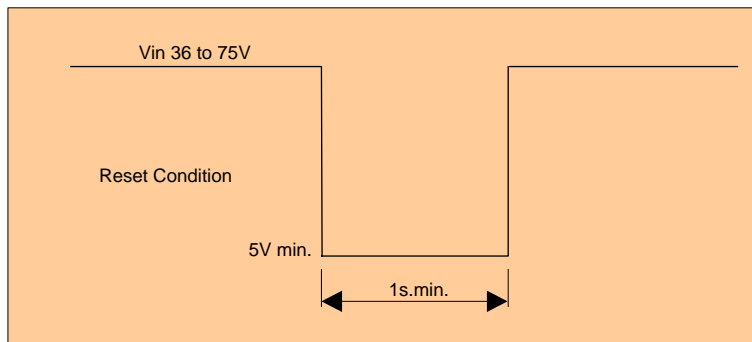

8-2-4 Remote On/Off Control

The connection to a RC pin controls an Isolated DC-DC Converter to turn on/off.

While the Isolated DC-DC Converter is halted via the remote control feature, the alarm function will not operate; refer to Alarm Output (Section 8-2-5).

Start: RC open or connected to -Vin

Halt: RC connected to +Vin

8-2-5 Alarm Output (ALM)

The Alarm Output can be down to the level of -Vin (Open Drain Output), when Over Voltage Protection or Low Voltage Protection features are activated. The sink current in ALM pin is 10mA max. Multiple Isolated DC-DC Converters running independently and/or in parallel operation can be simultaneously halted by connecting all ALM pins, when the Over Voltage Protection or Low Voltage Protection functions are activated by any single DC-DC Converter. The maximum number connected running DC-DC Converters is 10pcs.

To connect more than 10 please consult with Murata.

8-2-6 Synchronous Turn-On/Off

Multiple Isolated DC-DC Converters running independently and/or in parallel operation can be synchronously toggled on/off timing among the running converters, of which the input voltage detection circuits are tied to the detection voltage of a single reference Isolated DC-DC Converter. Every PO pin must be connected for multiple and/or parallel operation. The Maximum number connected running DC-DC Converters is 10pcs.

To connect more than 10 please consult Murata.

9. Reliability**9-1 Humidity**

40±2 degreeC, 90 to 95%RH, 100 hours. Leave for 4 hours at room temperature.

No damage in appearance and no deviation from electrical characteristics (Section 8-1).

According to JIS-C-0022.

9-2 Temperature Cycles

Repeat 5 times of the cycle. Leave for 2 hours at room temperature.

No damage in appearance and no deviation from electrical characteristics (Section 8-1).

Step	Temp.	Period.
1	-40±3°C	30 minutes
2	at room temp.	5 to 10 minutes
3	+85±3°C	30 minutes
4	at room temp.	5 to 10 minutes

9-3 Vibration

10 to 55Hz, 1.5mm amplitude, 1 hour for each each of X, Y, Z directions.

No damage in appearance and no deviation from electrical characteristics (Section 8-1).

9-4 Mechanical Shock

20G, 1 time for each X, Y, Z directions.

No damage in appearance and no deviation from electrical characteristics (Section 8-1).

9-5 Soldering Heat Resistance

Immerse lead pins in a solder bath of 260±5 degreeC for 3±0.5 seconds.

Then tested products are left for 2 hours.

No damage in appearance and no deviation from electrical characteristics (Section 8-1).

9-6 Lead Pin Strength

Strain lead pin by gradually-increasingl to 5.0N along axial direction; withstand for 5 seconds.

No damage to the lead pin.

9-7 Solderability of Leads

The lead pins will be immersed in the Isopropyl Alcohol (JIS K 1522) with Rosin (JIS K5902) solution (the concentration of Rosin ranging from 10 to 35wt%, and typically approx. 25wt% will be used without any specific requirement.).

Then the lead pins will be immersed in the solder H63A (JIS Z 3282) solution at the temperature of 230±5 degreeC for 3±0.5 seconds, and pulled up completely.

The solder will adhere to over 75% of immersed area.

10. Measurement Setup

10-1 Standard Test Circuit

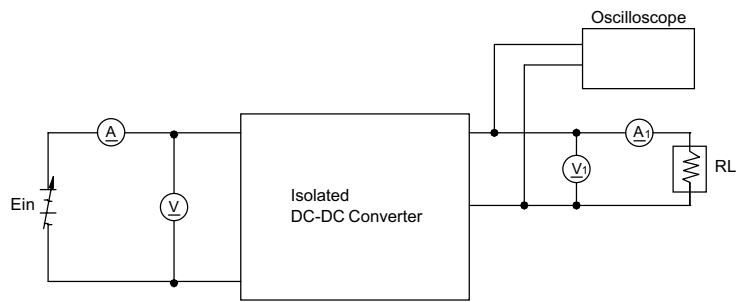

Ein : Stabilized DC Power Supply
 (A) (V) : Multimeter
 RL : Electronic or Resistive Load

10-1-1 Output Ripple and Noise

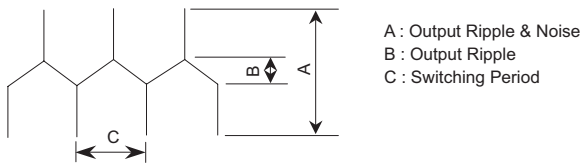
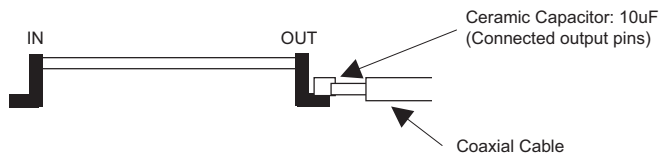
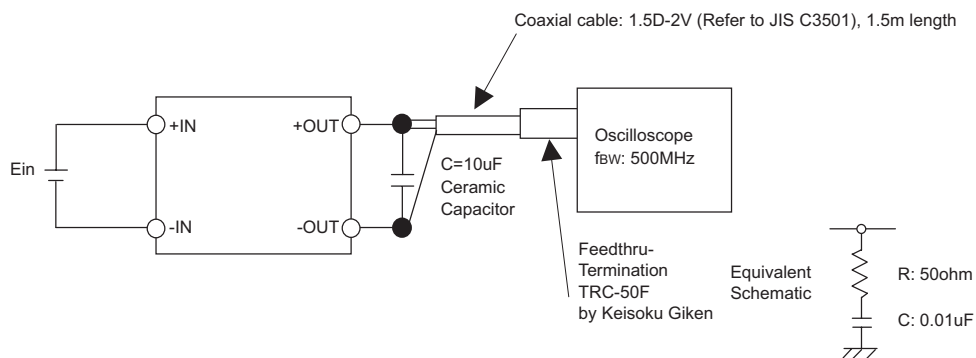

11-2 Maximum Pieces per a Tray.
21pcs/tray(except when less than 21)

11-3 Package

Corrugated cardboard box contains trays with products.

Tray is stacked with alternating opposite direction to prevent products from contacting against the bottoms of trays.

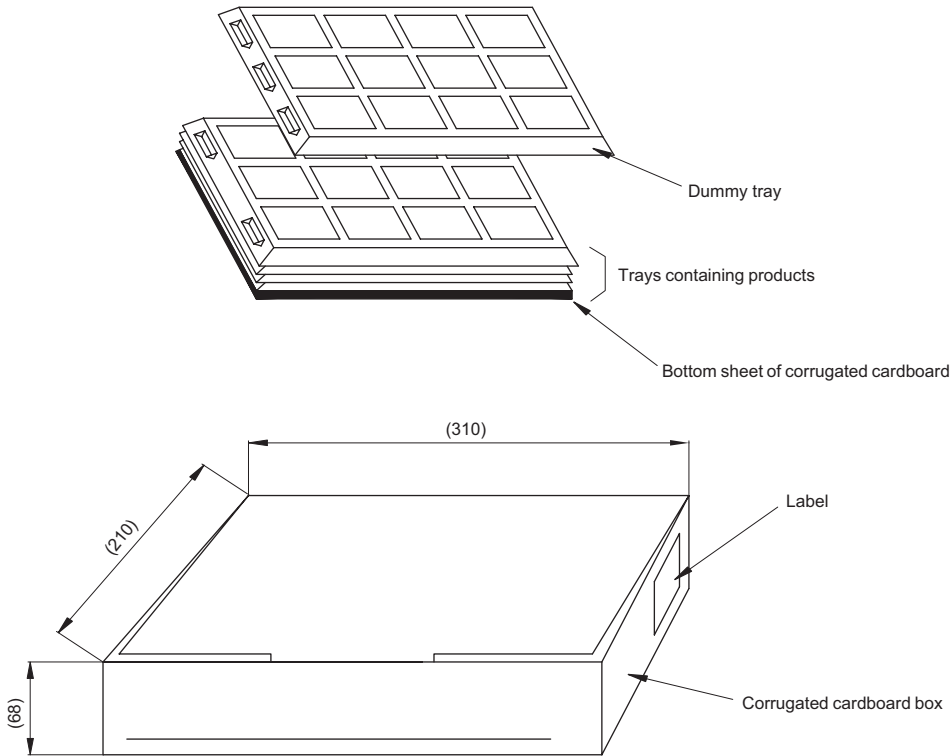

Numerals in parentheses are reference only.

(in mm)

Label ; written by: Part Number
: Quantity
: Inspection Number
: CE Marking

12. Notice**12-1 Soldering****12-1-1 Flux**

Please solder the products with Rosin Flux (0.2wt%. chloride or less).

Do not use acid or soluble flux, because they may damage metallic parts and glass parts and may cause defects or reduce quality.

12-1-2 Solder

Please use the solder H60, H63 (in JIS Z 3282) or equivalent.

Please use the same type solder as stated above when you use solder paste.

12-1-3 Condition of Soldering

Please solder under the following condition.

Reflow method	: Infrared or heated air
Peak temperature	: 230 degreeC at on product surface
Maximum period above 200 degreeC	: Max.30 seconds
Preheating	: 150±10 degreeC for 60 to 120 seconds
Times	: Max 2 times.

Do not allow vibration or an airing to product while solder melts under reflow process.

Please wait for products to cool down enough.

There is the possibility that products which are mounted on back side of motherboard may fall down from the motherboard while reflow process.

It is recommended supplemental mechanical contact to pins located at the four corners be used, by other adhesive methods, for example, a thermal setting resin, rather than soldering.

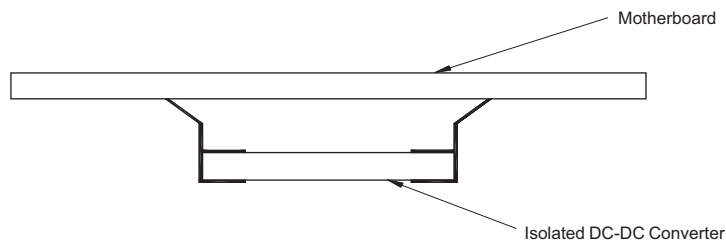
**12-2 Cleaning**

12-2-1 Please clean the products to remove flux by using the dip, boil, and vapor methods in isopropyl alcohol for up to 5 minutes.

Please inform us if you are to use aqueous or semi-aqueous cleaning or other methods.

Do not use ultrasonic cleaning because semiconductor device on the products may be damaged by resonance.

12-2-2 After cleaning, please dry the products thoroughly. If you touch the products while wet, the marking on the products may be erased or blurred.

Do not measure electrical characteristics, until the products are thoroughly dried.

12-2-3 If you do not clean the products with a no-clean type flux, you must confirm the reliability of the products fully in advance.

12-3 Storage

12-3-1 Please store the products in a room where the temperature/humidity is stable and direct sunlight cannot come in, and use the products within 6 months of delivery.

Avoid damp heated places or such places where there are large temperature changes, because water may condense on the products, the characteristics may be reduced in quality, and/or be degraded in solderability.

If you store the products for a long time (more than 1 year), use caution because the products may be degraded in solderability and/or corroded.

Please confirm solderability and characteristics for the products regularly.

12-3-2 Please do not store the products in the places such as: in a dusty place, in a place exposed directly to sea breeze, in a place in an atmosphere containing corrosive gas (Cl₂, NH₃, SO₂, NO_x and so on).

12-4 Operation Environment and Conditions

12-4-1 Operation Environment

The products are not waterproof, chemical-proof or rust proof.

In order to prevent leakage of products and abnormal temperature increase of the products, do not use under the following circumstances:

- (1) in an atmosphere containing corrosive gas
(Cl₂, NH₃, SO₂, NO_x and so on)
- (2) in a dusty location
- (3) in a location exposed to direct sunlight
- (4) in such a location where water splashes or in high humidity environment where water condenses
- (5) in a place exposed to sea breeze
- (6) in any other location similar to the above (1) through (5)

12-4-2 Operation Conditions

Please use the products within specified values (power supply, temperature, input, output and load condition, and so on).

If you use the products outside of specified values, the products may be destroyed, reduce the quality, and though products may endure the stressed condition for a short time, it may degrade reliability.

Inserting a fuse into input or Vin is recommended to secure safety in case of any abnormal occurrence such as internal Isolated DC-DC Converter circuit broken down.

Please do not apply more voltage than one's rated output from external circuit to output pins.

12-4-3 Handling

If you apply high static electricity over rated voltage or a reverse voltage to the products, it may cause defects in the products or degrade the reliability.

Please avoid the following conditions:

- (1) Over rated voltage applied, reverse voltage applied under measurement or insufficient connection of 0 V(DC) line
- (2) Electrostatic discharge from production line and/or operators
- (3) Electrically charged appliances by electrostatic induction

Do not expose to an excessive mechanical shock.

If you drop the products on the floor, etc., it may crack the core of inductors and monolithic ceramic capacitors.

Do not expose to strong shocks such as drops in handling.

Flexibility of products is limited to up to 0.2mm as bending the substrate.

12-5 Transportation

If you transport the products, please wrap-up in addition to the standard packaging.

Otherwise mechanical vibrations or mechanical shocks, may damage the package, and please direct transporters to handle with care.

If you transport the products overseas (in particular, by ocean vessel), it is expected that the transportation environment will be the worst. So please pack the products, in the package designed with consideration of mechanical strength, vibration-resistant and humidity-resistance.

The packaging of the products, which Murata sells in Japan, may not resist over seas transport.

Please consult us if you are to use the standard package of the products sold in Japan for transport to overseas.

13. Production Factories

Komatsu Murata Mfg.Co.,Ltd.

Wakura Murata Mfg.Co.,Ltd.

Kanazu Murata Mfg.Co.,Ltd.

Note

1. In the unlikely event of abnormal or trouble of products, it is recommended that the appropriate fail-safe function be connected to it to prevent any possible secondary damage.
2. Please contact our sales representatives or product engineers before using our products for the applications listed below which require especially high reliability for the prevention of defects which might directly cause damage to the third party's life, body or property.
 1. Aircraft Equipment
 2. Aerospace Equipment
 3. Undersea Equipment
 4. Atomic Power Plant Equipment
 5. Medical Equipment
 6. Transportation Equipment (Vehicles, Trains, Ships, etc.)
 7. Traffic Signal Equipment
 8. Disaster Prevention/Crime Prevention Equipment
 9. Data-processing Equipment
 10. Application of similar complexity and/or reliability requirements to the applications listed in the above.

Request to Customer

1. Please evaluate the products mounted on your Equipment.
2. Contents specified in this document are based on the preconditions of the purpose, condition and environment to which Murata has agreed with customers.

Please do not use these products deviating from application described in the specification.

We consider it inappropriate to include other terms and conditions for transaction warranty in product specifications, drawings or other technical documents. Therefore, if your technical documents as above include such terms and conditions as a warranty clause, product liability clause, or intellectual property infringement liability clause, we will not be able to accept such terms and conditions unless they are based on the governmental regulation or they are stated in a separate contract agreement.

**The document is for reference only and is subject to revision without notices.
Please contact Murata for formal documentation.**