

# DC-DC Converter Specification(DRAFT)

## MP6D11\*S

### 1 . Application

This specification applies to DC-DC Converter MPD6D11\*S(\*:1~9) for telecommunication / data-communication equipment.

For any other application, please contact us before using this product.

### 2 . Customer Reference

Customer Spec. Number  
Customer Part Number

### 3 . Customer & Murata Part Number

Nominal Output Voltage	Customer Part Number	Part Number
1.2V		MPD6D112S
1.5V		MPD6D113S
1.8V		MPD6D114S
2.5 V		MPD6D116S
3.3V		MPD6D117S
5.0V		MPD6D118S
5.2V		MPD6D119S
12.0V		MPD6D111S

#### ⚠ Note:

1. This datasheet is downloaded from the website of Murata Manufacturing co., ltd. Therefore, it's specifications are subject to change or our products in it may be discontinued without advance notice. Please check with our sales representatives or product engineers before ordering.
2. This datasheet has only typical specifications because there is no space for detailed specifications. Therefore, please approve our product specifications or transact the approval sheet for product specifications before ordering.

## 4. Appearance, Dimensions

Objective Products MPD6D11\*S (\* : 1,2,3,4,6,7,8,9)

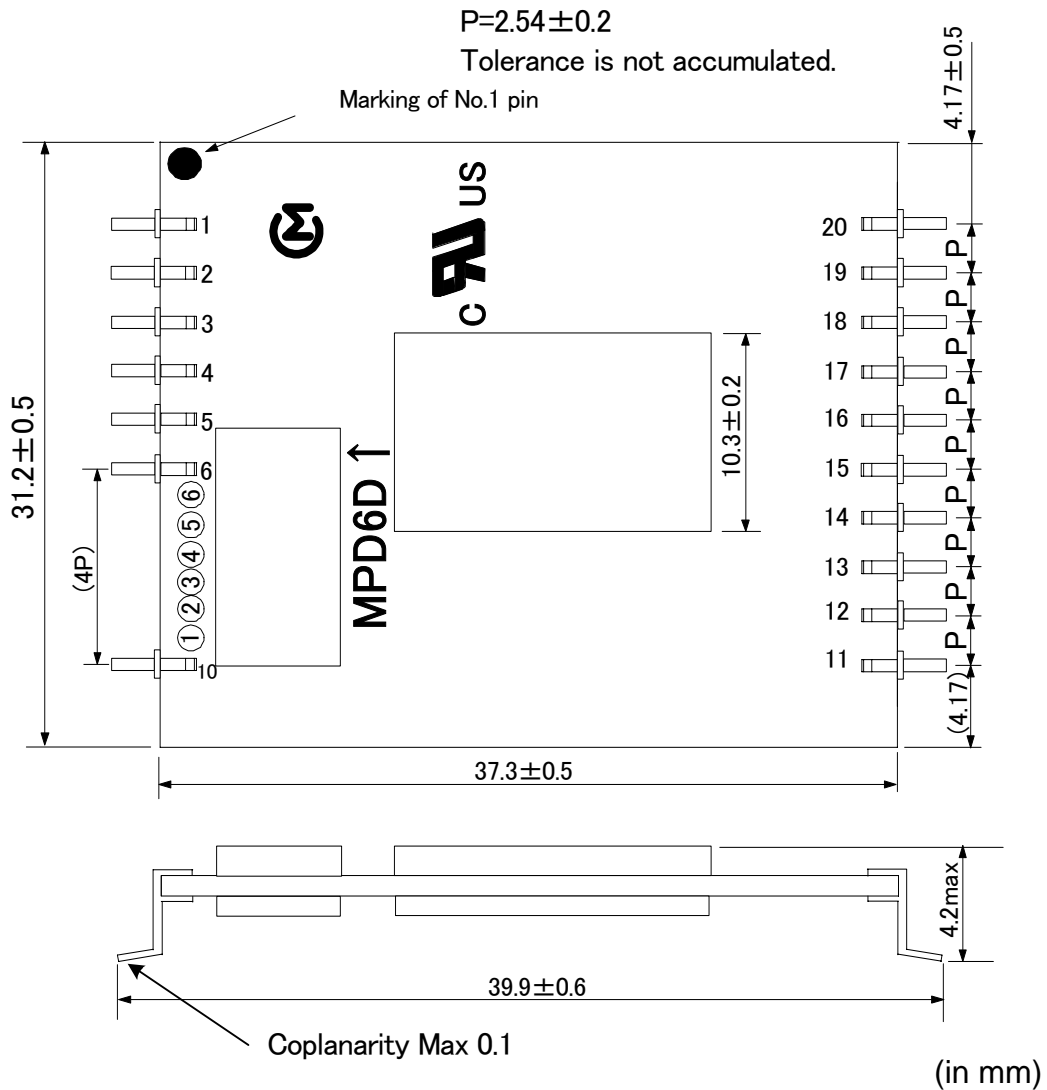

## Marking

Part Number MPD6D11\_  
(Omitted S of MPD6D11\_S)

Murata CM Mark 

Lot Number

1) Factory symbol

2) The last number of production year. Example:2 stands for 2002

3) Production month. Example:1 stands for January

9 stands for September

O stands for October

N stands for November

D stands for December

4)

5) 111,112,113,114,116,117,118,119 which is \_\_\_ of MPD6D\_\_\_S

6)

## ⚠ Note:

- This datasheet is downloaded from the website of Murata Manufacturing co., ltd. Therefore, it's specifications are subject to change or our products in it may be discontinued without advance notice. Please check with our sales representatives or product engineers before ordering.
- This datasheet has only typical specifications because there is no space for detailed specifications. Therefore, please approve our product specifications or transact the approval sheet for product specifications before ordering.

## 5 . Pin Number and Function

Pin No	Pin Symbol	Function
1,10, 11,20	NCo	Mechanical supplemental contact pins. Pins at the four corners on printed circuit board. To contact DC-DC Converter mounted board with thermal setting resin.
2	+Vout	(+)Output
3	+Vout	(+)Output
4	+Vout	(+)Output
5	-Vout	(-)Output
6	-Vout	(-)Output
12	ALM	Alarm Output
13	RC	Remote On/Off Control
14	PO	Parallel Operation
15	NC	-
16	+Vin	(+)Input
17	+Vin	(+)Input
18	-Vin	(-)Input
19	-Vin	(-)Input

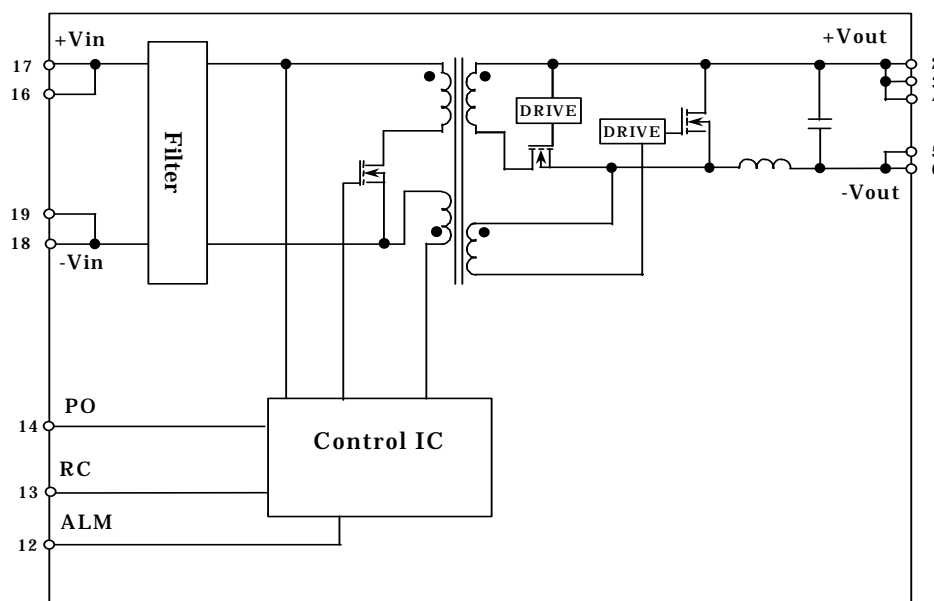
6. Block Diagram  
6.1 Entire Product

## ⚠ Note:

1. This datasheet is downloaded from the website of Murata Manufacturing co., ltd. Therefore, it's specifications are subject to change or our products in it may be discontinued without advance notice. Please check with our sales representatives or product engineers before ordering.
2. This datasheet has only typical specifications because there is no space for detailed specifications. Therefore, please approve our product specifications or transact the approval sheet for product specifications before ordering.

## 7. Environmental Conditions

- |                                 |                                     |
|---------------------------------|-------------------------------------|
| 7.1 Operating Temperature Range | -40°C ~ +85°C (With power derated.) |
| 7.2 Operating Humidity Range    | 20% ~ 85% (No water condenses.)     |
| 7.3 Storage Temperature Range   | -45°C ~ +90°C                       |
| 7.4 Storage Humidity Range      | 10% ~ 95%( No water condenses.)     |

## 8. Absolute Rating

Item	Unit	Absolute Rating	Remarks
Minimum Input Voltage	V	0	
Maximum Input Voltage ALM Applied Voltage RC Applied Voltage	Time	Continuous	V 75
		200µs	V 90 Slew rate 42V/10µs
PO Applied Voltage	V	8	
Maximum ALM Sink Current	mA	10	

No voltage, no matter how instantaneous, shall be applied beyond the absolute maximum voltage rating to this product.

If you apply any voltage over this limit, the product characteristics will deteriorate or the product itself will be destroyed.

Even though it may continue operating for a while after the over-voltage event, its life will likely be shortened significantly. Reliability and life of the module may degrade similarly if the maximum operating voltage rating is continuously exceeded. This product is designed to operate within the maximum operating voltage rating specification.

## 9. Characteristics

## 9.1 Electrical Characteristics (Ta=25°C)

## 9.1.1 General Characteristics

Unless otherwise specified, (Ta= -40 to +85°C with power derated.)

Items	Unit	Value	Remark
Rated Input Voltage	V	48	
Input Voltage Range	V	36 to 60	No powerderating with 0.2m/s(40LFM)
		36 to 75	No powerderating with 0.5m/s(100LFM).
		36 to 75	Powerderating with 0m/s(0LFM)
Turn-on Input Voltage	V	32.0 to 36.0	
Hysterisis Voltage	V	Minimum 2	Input voltage difference between turn-on and turn-off
Galvanic Isolation Voltage	Vdc	Minimum 1500	For one minute between input and output
EMC (Radiated EMI / Conduction)		In accordance with CISPR Publication22,Class A (VCCI Class A)	
Safty Standards		UL60950(UL / C-UL)	Recognized
CE Marking		Attached	Self-declaration

## ⚠ Note:

- This datasheet is downloaded from the website of Murata Manufacturing co., ltd. Therefore, it's specifications are subject to change or our products in it may be discontinued without advance notice. Please check with our sales representatives or product engineers before ordering.
- This datasheet has only typical specifications because there is no space for detailed specifications. Therefore, please approve our product specifications or transact the approval sheet for product specifications before ordering.

## 9 .1 .2 Specific Characteristics (Ta= -40 to +85°C with power derated.)

Items		Models								Unit
		MPD6D___S where ___ is in below cells.								
		111	112	113	114	116	117	118	119	
Nominal Output Voltage		12.0	1.2	1.5	1.8	2.5	3.3	5.0	5.2	V
Output Voltage Regulation Vin =36 to 75V Output current range = 0 to 100%		+5%,-3%								%
Nominal Output Current		1.2	5.2	5.2	4.5	4.5	4.5	3.0	3.0	A
Output Current-limit Inception	Min	1.23	5.35	5.35	4.63	4.63	4.63	3.09	3.09	A
Over Voltage Protection : Note 1	Min	14.4	1.44	1.80	2.16	3.00	3.96	6.00	6.24	V
Low Voltage Protection :Note 2	Max	10.8	1.08	1.35	1.62	2.25	2.97	4.50	4.68	V
Efficiency(typ.) Ta=25°C, Vin = 48V, Nominal output current		86	82	84	87	88	90	90	90	%
Output Ripple and Noise	Max	100	50					Note 3		mVp-p
Output Ripple	Max	50	25					Note 3		mVp-p

Note 1: Output halted in latch-up mode after mask time 0.5ms(typ.), which prevents DC-DC Converter from malfunction by external noise and/or transient output voltage change.

Note 2: Output halted in latch-up mode after mask time 500ms(typ.), which prevents DC-DC Converter from malfunction by external noise and/or transient output current change.

Note 3: Refer to 10.Measure Construction.

⚠ **Note:**

1. This datasheet is downloaded from the website of Murata Manufacturing co., ltd. Therefore, it's specifications are subject to change or our products in it may be discontinued without advance notice. Please check with our sales representatives or product engineers before ordering.
2. This datasheet has only typical specifications because there is no space for detailed specifications. Therefore, please approve our product specifications or transact the approval sheet for product specifications before ordering.

## 9-1-3-1 .Typical Power derating of MPD6D112S to MPD6D119S

Nominal output currents are attainable with 0.5m/s(100LFM), Vin=36to75V or 0.2m/s(40LFM), Vin=36to60V. Powerderatings are required under 0m/s(0LFM), Vin=36to75V.

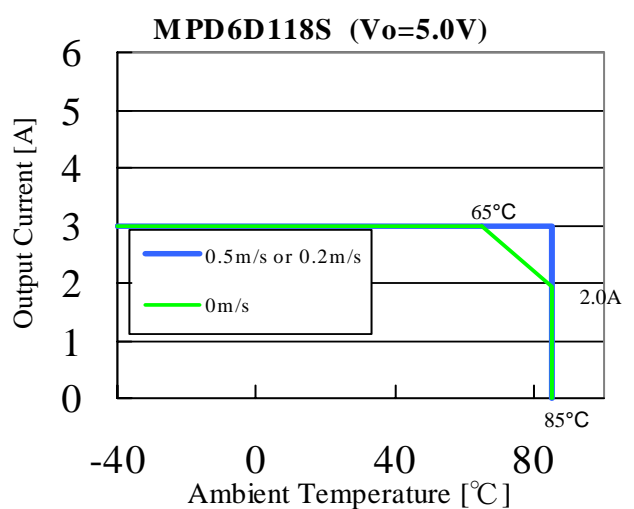
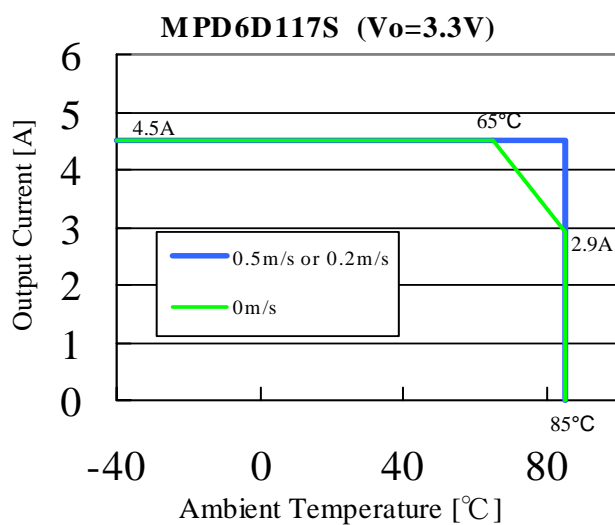
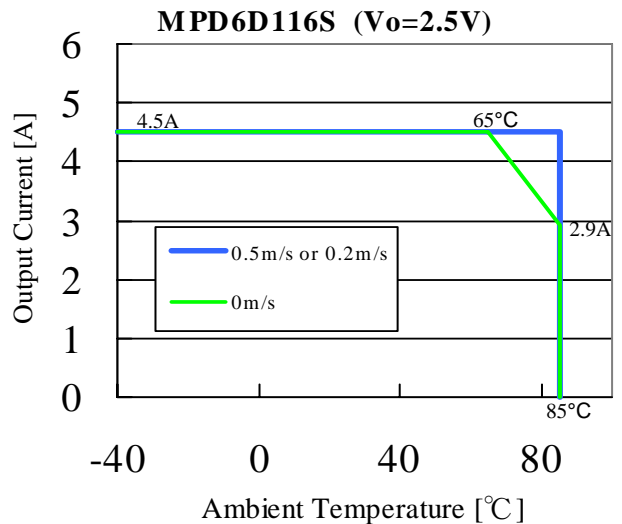
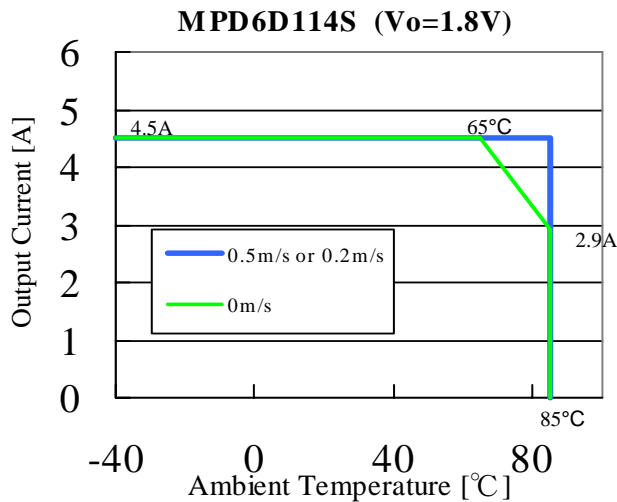
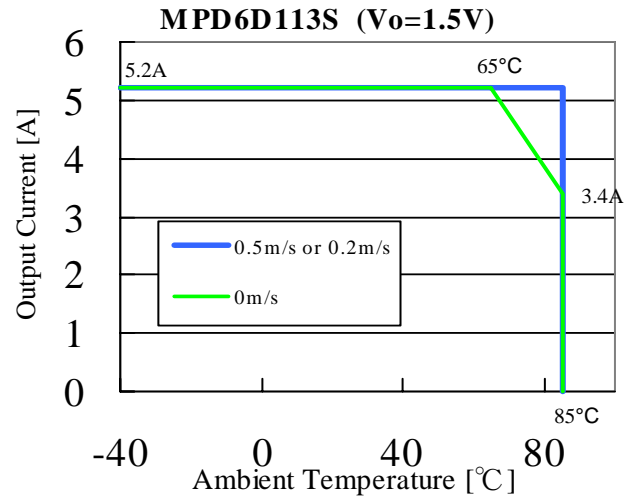
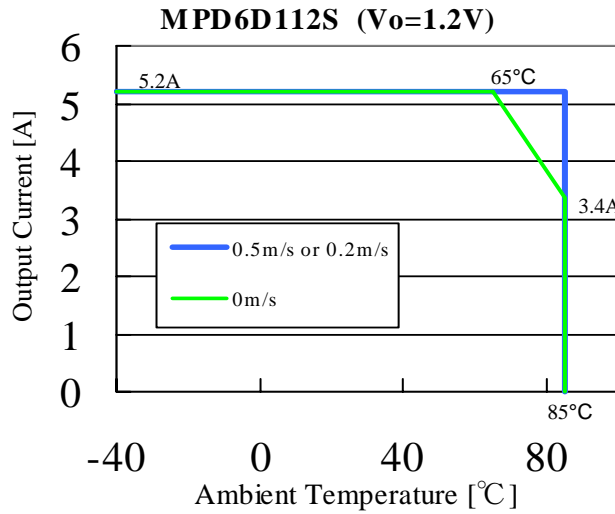

⚠ **Note:**

1. This datasheet is downloaded from the website of Murata Manufacturing co., ltd. Therefore, it's specifications are subject to change or our products in it may be discontinued without advance notice. Please check with our sales representatives or product engineers before ordering.
2. This datasheet has only typical specifications because there is no space for detailed specifications. Therefore, please approve our product specifications or transact the approval sheet for product specifications before ordering.

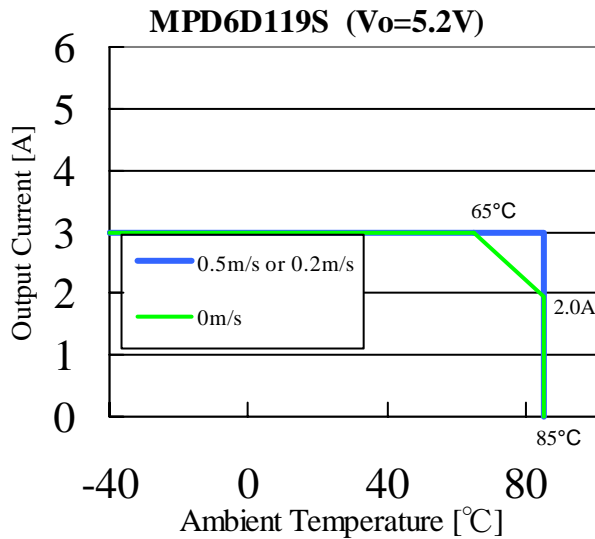

9-1-3-2 .Typical Power derating of MPD6D111S

Nominal output currents are attainable in Vin=36 to 60V or Vin=60 to 75V with various air flows of 0.2m/s(40LFM),0.5m/s(100LFM),0.8m/s(160LFM),1.0m/s(200LFM).

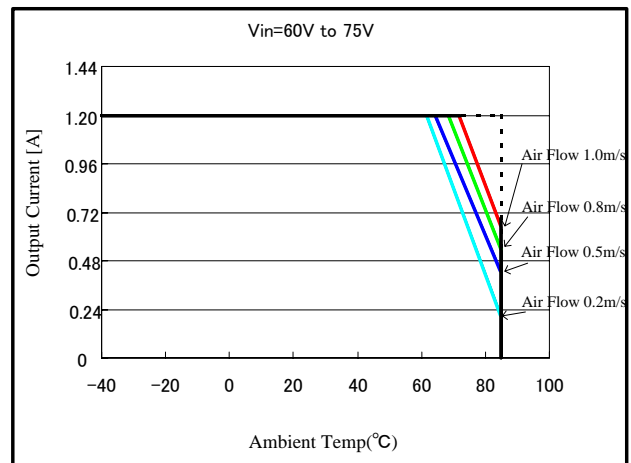
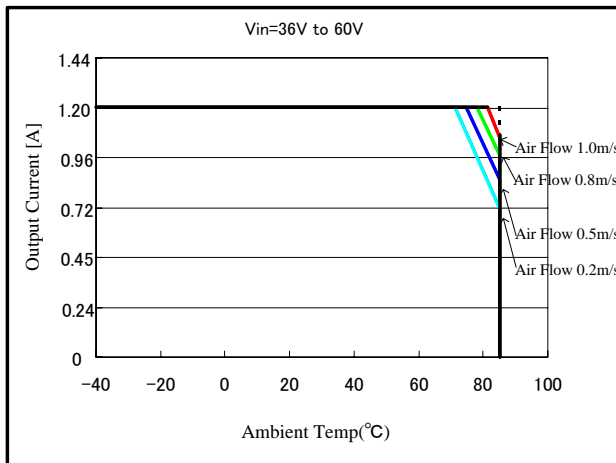

9-2. Operation Information

9-2-1. Reset Condition

In order to reset all function , the input voltage (Vin) is set under 5V for 1s. min.

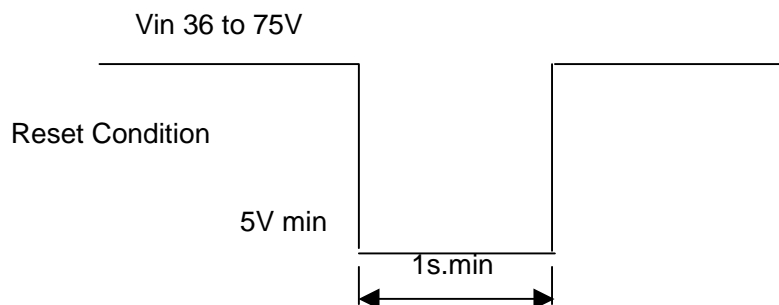

⚠ Note:

1. This datasheet is downloaded from the website of Murata Manufacturing co., ltd. Therefore, it's specifications are subject to change or our products in it may be discontinued without advance notice. Please check with our sales representatives or product engineers before ordering.
2. This datasheet has only typical specifications because there is no space for detailed specifications. Therefore, please approve our product specifications or transact the approval sheet for product specifications before ordering.

### 9-2-2. Over Voltage Protection (OVP)

The Isolated DC-DC Converter become into latch-up mode after typical 0.5ms. mask time,when the output voltage is over the value specified in Over Voltage Protection(8.1.2) by failure of internal control circuit. In order to reset, the input voltage is set under 5V for 1s. min. Output voltage might exceed the point at which OVP starts to function under the specific condition of transient input voltage or output current change. Therefore,OVP is set to wait for the mask time 0.5ms. It is recommended to evaluate your appliances installed with the DC-DC Converter.

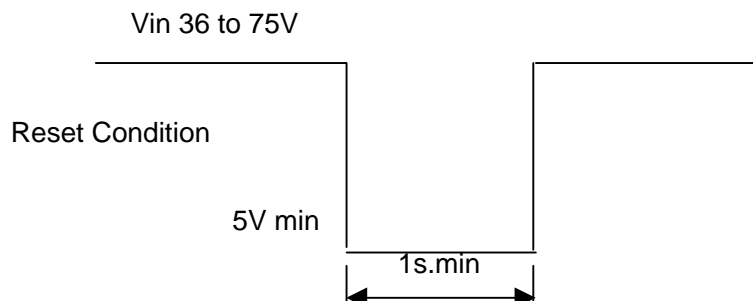

### 9-2-3. Low Voltage Protection (LVP)

The Isolated DC-DC Converter becomes into latch-up mode after typical 500ms. mask time,when the output voltage is under the value specified in Low Voltage Protection(8.1.2) by operating Over Current-limit Inception due to failure of internal control or over load. In order to reset, the input voltage is set under 5V for 1s. min.

### 9-2-4. Remote On/Off Control

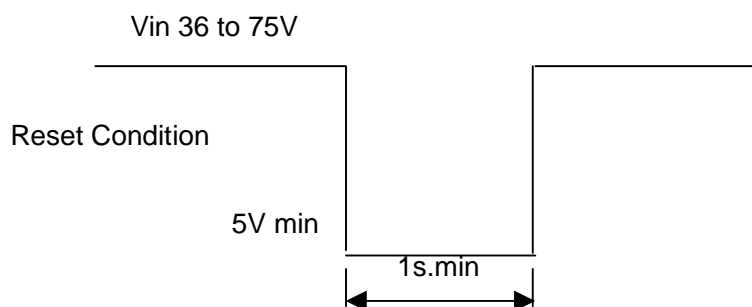

The connection to a RC pin controls an Isolated DC-DC Converter to turn on/off. While the Isolated DC-DC Converter is halted under the remote control, alarm function does not operate;refer to Alarm Output.

Start : RC is open or connected to -Vin  
Halt : RC is connected to +Vin

### 9-2-5. Alarm Output (ALM)

The Alarm Output can be down to the level of -Vin (Open Drain Output), when Over Voltage Protection or Low Voltage Protection operates. Sink current in ALM pin is 10mA max. The Isolated DC-DC Converter running for multiple and/or parallel operation are enable to simultaneously halt by connecting all ALM pins, in the case of Over Voltage Protection or Low Voltage Protection caused by any single DC-DC Converter. Maximum number running DC-DC Converters is 10pcs. To connect more than 10,please consult Murata.

#### ⚠ Note:

1. This datasheet is downloaded from the website of Murata Manufacturing co., ltd. Therefore, it's specifications are subject to change or our products in it may be discontinued without advance notice. Please check with our sales representatives or product engineers before ordering.
2. This datasheet has only typical specifications because there is no space for detailed specifications. Therefore, please approve our product specifications or transact the approval sheet for product specifications before ordering.

### 9-2-6. Synchronous Turn-on/off

The Isolated DC-DC Converters running for multiple and / or parallel operation are enable to synchronize turn-on/off timing among the running converters, of which the input voltage detection circuits are unified to the detection voltage of a certain Isolated DC-DC Converter. Every PO pin is necessary to be connected for multiple and/or parallel operation. Maximum number running DC-DC Converters is 10pcs.To connect more than 10,please consult Murata.

## 9. 3 Reliability

### 9. 3. 1 Humidity Test

Parts are subjected to a temperature  $40^{\circ}\text{C} \pm 2^{\circ}\text{C}$  with 90~95% for 100 hours.

Return the parts to room temperature ( $25^{\circ}\text{C}$ ) for 4 hours and measure. The initial values under item 9-1 should be met. (JIS-C-0022)

### 9. 3. 2 Thermal Cycle Test

Parts are subjected to 5 cycle of the following.

The parts are placed in room temperature ( $25^{\circ}\text{C}$ ) for 2 hours and are measured.

The initial values under item 9-1 should be met.

Step	Condition	Time
1	$-40 \pm 3^{\circ}\text{C}$	30 minutes
2	Room Temp.	5~10 minutes
3	$+85 \pm 3^{\circ}\text{C}$	30 minutes
4	Room Temp.	5~10 minutes

### 9. 3. 3 Vibration

10 to 55Hz, 1.5mm amplitude, 1 hour for each each of X,Y,Z directions.

No damage in appearance and no deviation from electrical characteristics(9-1).

### 9. 3. 4 Mechanical Shock

20G, 1 time for each X,Y,Z directions.

No damage in appearance and no deviation from electrical characteristics(9-1).

### 9. 3. 5 Soldering Heat Resistance

Immerse the part of lead where it is to be soldered on a motherboard in a solder bath of  $260 \pm 5^{\circ}\text{C}$  for  $3 \pm 0.5\text{s}$ .

Then tested products are left for 2 hours.

There is no damage in appearance and no deviation from electrical characteristics in clause 9.

### 9-3-6. Lead Pin Strength

Strain a lead pin by gradual-increasingly 5.0N along axial direction; withstand for 5s.

No damage on a lead pin.

### 9-3-7. Solderability of Leads

The lead pins will be immersed in the Isopropyl Alcohol (JIS K 1522) with Rosin (JIS K 5902) solution (the concentration of Rosin will be allowed 10wt% to 35wt%, and normally approx.25wt% will be used without any specific requirement.). Then the lead pins will be immersed in the solder H63A (JIS Z 3282) solution at the temperature of  $230^{\circ}\text{C} \pm 5^{\circ}\text{C}$  for  $3 \pm 0.5\text{seconds}$ , and pulled up completely. The solder will adhere to over 75% of immersed area.

#### ⚠ Note:

1. This datasheet is downloaded from the website of Murata Manufacturing co., ltd. Therefore, it's specifications are subject to change or our products in it may be discontinued without advance notice. Please check with our sales representatives or product engineers before ordering.
2. This datasheet has only typical specifications because there is no space for detailed specifications. Therefore, please approve our product specifications or transact the approval sheet for product specifications before ordering.

10. Measure Construction

10-1. Standard Test Circuit

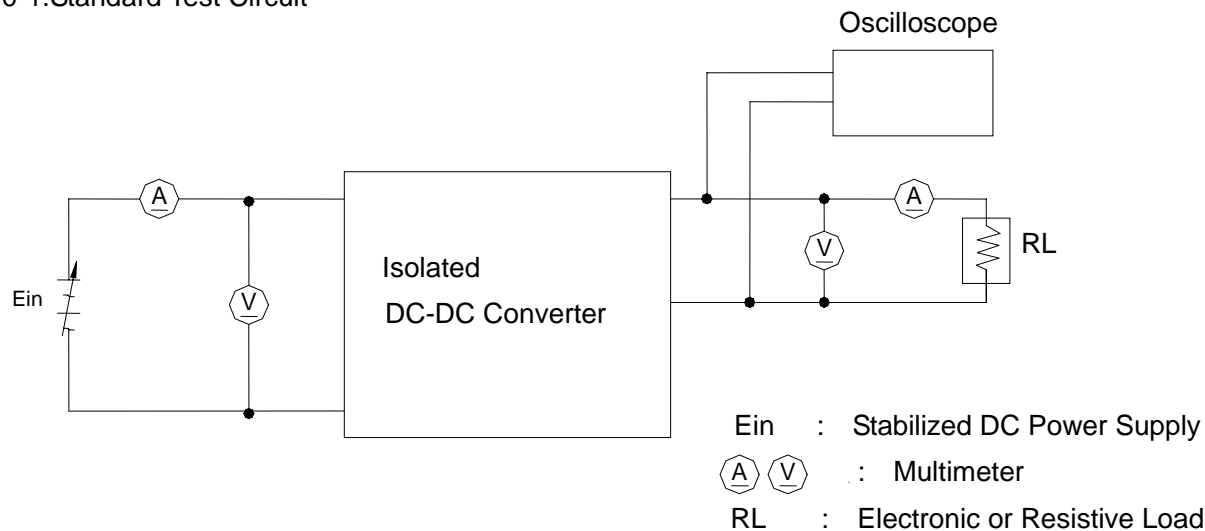

10.1.1 Output Ripple & Noise

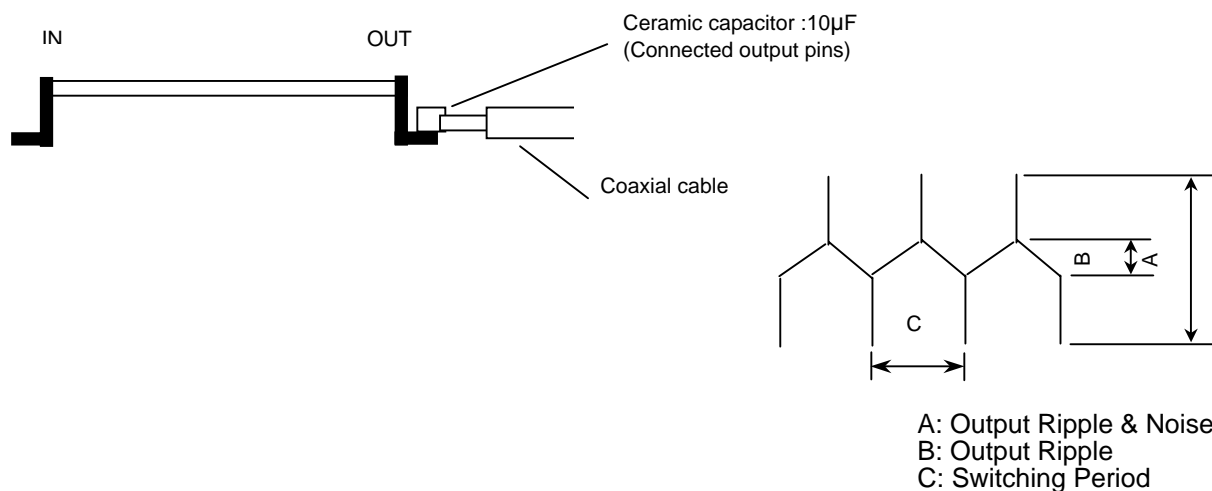
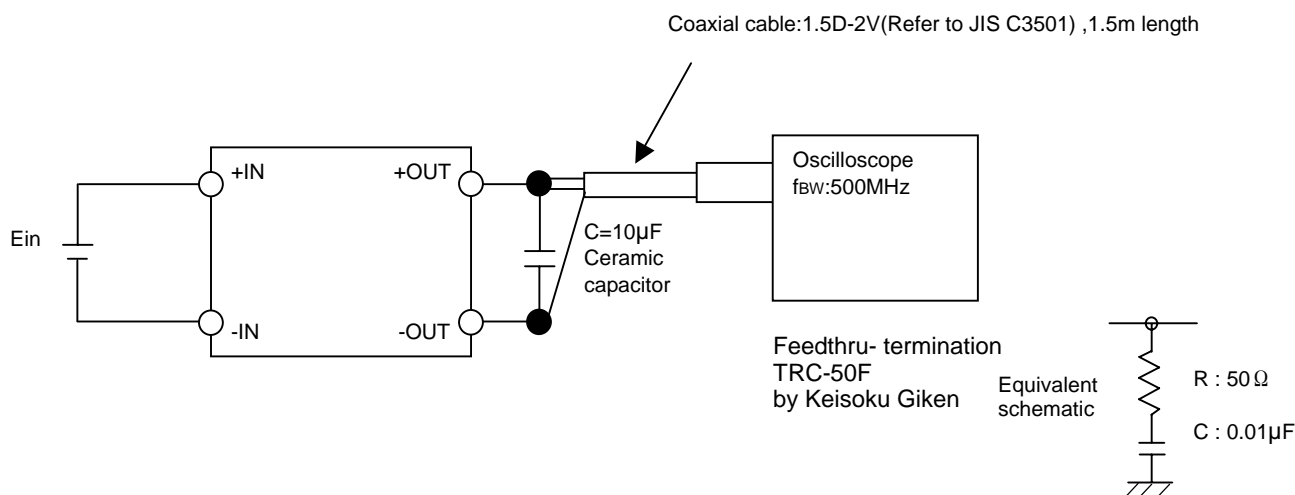

⚠ Note:

1. This datasheet is downloaded from the website of Murata Manufacturing co., ltd. Therefore, it's specifications are subject to change or our products in it may be discontinued without advance notice. Please check with our sales representatives or product engineers before ordering.
2. This datasheet has only typical specifications because there is no space for detailed specifications. Therefore, please approve our product specifications or transact the approval sheet for product specifications before ordering.

## 11. Packaging Information

## 11.1 Tray Dimensions

DC-DC Converters are put in the trays.

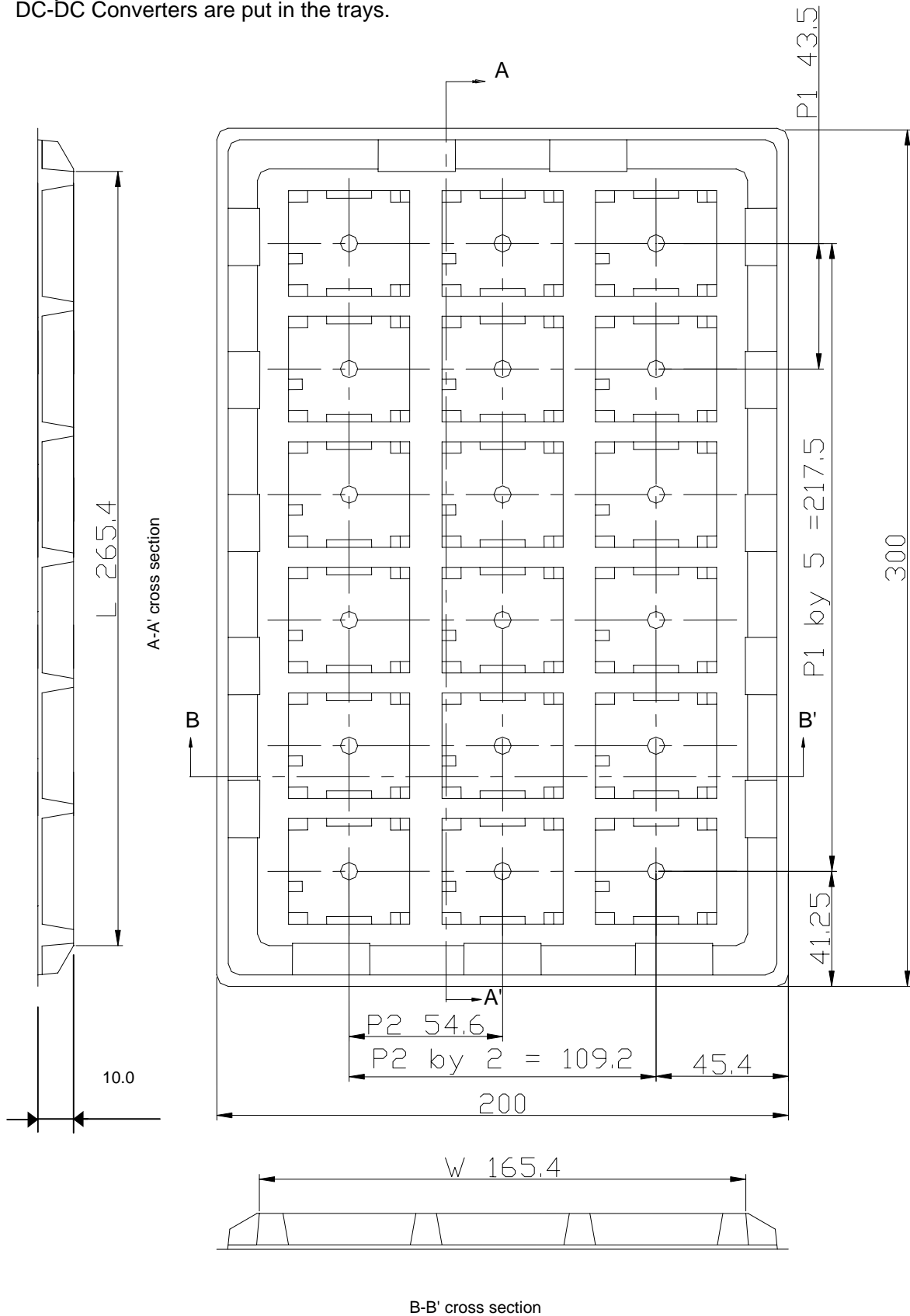

## ⚠ Note:

1. This datasheet is downloaded from the website of Murata Manufacturing co., ltd. Therefore, it's specifications are subject to change or our products in it may be discontinued without advance notice. Please check with our sales representatives or product engineers before ordering.
2. This datasheet has only typical specifications because there is no space for detailed specifications. Therefore, please approve our product specifications or transact the approval sheet for product specifications before ordering.

11-2. Maximum Pieces per a Tray.  
18pcs/tray(except less than 18)

### 11-3. Package

Corrugated cardboard box contains trays with products.

Tray is heaped with alternately opposite direction to prevent products from contacting against the bottoms of trays.

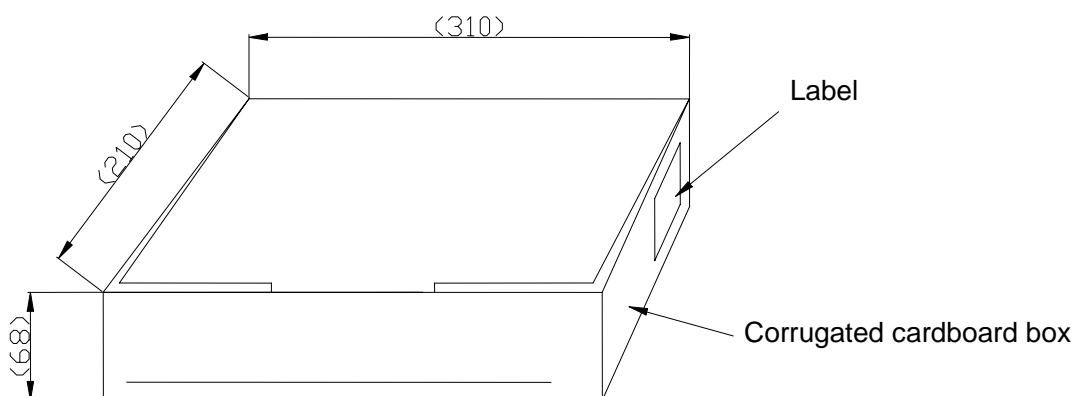
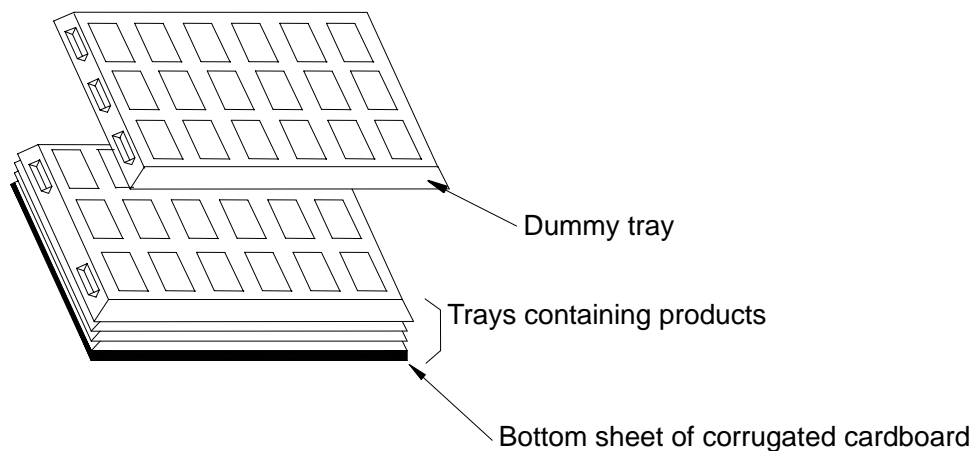

Numerals in parentheses are reference only.

Unit : mm

Label ; written by : Part Number,  
: Quantity,  
: Inspection Number,  
: CE Marking.

#### ⚠ Note:

1. This datasheet is downloaded from the website of Murata Manufacturing co., ltd. Therefore, it's specifications are subject to change or our products in it may be discontinued without advance notice. Please check with our sales representatives or product engineers before ordering.
2. This datasheet has only typical specifications because there is no space for detailed specifications. Therefore, please approve our product specifications or transact the approval sheet for product specifications before ordering.

## 12. Notice

### 12-1. Soldering

#### 12-1-1. Flux

Please solder the products with Rosin Flux (0.2wt%. chloride or less).  
Do not use acid or soluble flux, because they may damage metallic parts and glass parts and may cause defective or reduce quality.

#### 12-1-2. Solder

Please use the solder H60, H63 (in JIS Z 3282) or the equivalent type.  
Please use the same type solder as stated above when you use solder paste.

#### 12-1-3. Condition of Soldering

Please solder under the following condition

Reflow method	: Infrared or heated air
Peak temperature	: 230°C at on product surface
Maximum period above 200°C	: Max.30s
Preheating	: 150±10°C for 60 to 120s
Times	: Max 2 times.

Do not give vibration or an airing to product while solder melts under reflow process.  
Please wait for products cooled down enough.  
There is the possibility that products which are mounted on back side of motherboard may fall down from the motherboard while reflow process.  
Recommend to use supplemental mechanical contact to pins where is located at four corners, by other adhesive methods, for example, a thermal setting resin, rather than soldering.

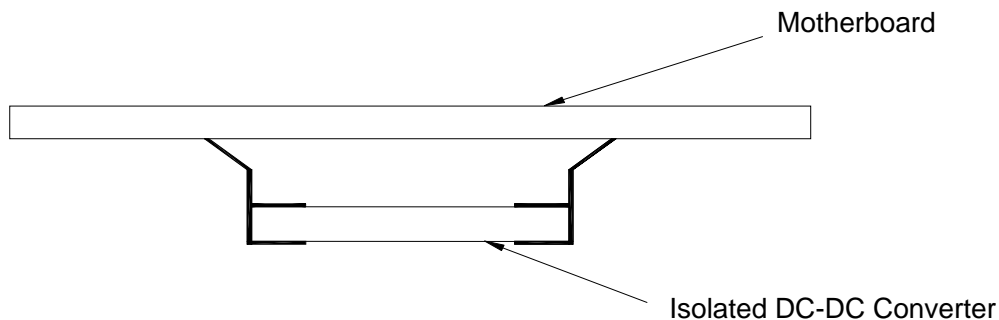

### 12-2. Cleaning

12-2-1. Please clean the products to remove flux by using the dip, boil, and vapor methods in isopropyl alcohol for up to 5 minutes.

Please inform us if you are to use aqueous or semi-aqueous cleaning or other methods.  
Do not use ultrasonic cleaning because semiconductor device on the products may be damaged by resonance.

12-2-2. After cleaning, please dry the products thoroughly. If you touch the wet products, the marking on the products may be erased or blurred.

Do not measure electrical characteristics, until the products get dried enough.

12-2-3. If you don't clean the products with no-cleaning type flux, you must confirm the reliability of the products fully in advance.

#### ⚠ Note:

1. This datasheet is downloaded from the website of Murata Manufacturing co., ltd. Therefore, it's specifications are subject to change or our products in it may be discontinued without advance notice. Please check with our sales representatives or product engineers before ordering.
2. This datasheet has only typical specifications because there is no space for detailed specifications. Therefore, please approve our product specifications or transact the approval sheet for product specifications before ordering.

### 12-3. Storage

12-3-1. Please store the products in room where the temperature/humidity is stable and direct sunlight cannot come in, and use the products within 6 months after delivery. Avoid damp heated places or such places where there are large temperature changes, because water may condense on the products, the characteristics may be reduced in quality, and/or be degraded in the solderability. If you store the products for a long time (more than 1 year), use caution because the products may be degraded in the solderability and/or rusty. Please confirm solderability and characteristics for the products regularly.

12-3-2. Please do not store the products in the places such as : in a dusty place, in a place exposed directly to sea breeze, in a place in an atmosphere containing corrosive gas (Cl<sub>2</sub>, NH<sub>3</sub>, SO<sub>2</sub>, NO<sub>x</sub> and so on).

### 12-4. Operation Environment and Conditions

#### 12-4-1. Operation Environment

The products are not waterproof, chemical-proof or rusts proof. In order to prevent leakage of products and abnormal temperature increase of the products, do not use the products under the following circumstances:

- (1) in an atmosphere containing corrosive gas (Cl<sub>2</sub>, NH<sub>3</sub>, SO<sub>2</sub>, NO<sub>x</sub> and so on)
- (2) in a dusty place
- (3) in a place exposed to direct sunlight
- (4) in such a place where water splashes or in such a humid place where water condenses.
- (5) in a place exposed to sea breeze
- (6) in any other places similar to the above (1) through (5)

#### 12-4-2. Operation Conditions

Please use the products within specified values (power supply, temperature, input, output and load condition, and so on). If you use the products over the specified values, it may break the products, reduce the quality, and even if the products can endure the condition for short time, it may cause degradation of the reliability. To insert fuse into input or V<sub>in</sub> is recommended to secure safety in any abnormality such as internal Isolated DC-DC Converter circuit broken down. Please do not apply more voltage than one's rated output from external circuit to output pins.

#### 12-4-3. Handling

If you apply high static electricity over rated voltage or reverse voltage to the products, it may cause defects in the products or degrade the reliability.

Please avoid the following items :

- (1) over rating voltage apply, reverse voltage apply under measurement or not-enough connection of 0 V(DC) line
- (2) electrostatic discharge by production line and/or operators
- (3) electrified appliances by electrostatic induction

Do not give an excessive mechanical shock.

If you drop the products on the floor, etc., it may crack the core of inductors and monolithic ceramic capacitors.

Do not give strong shocks such as drops in handling.

Flexibility of products is limited up to 0.2mm as bending the substrate

#### ⚠ Note:

1. This datasheet is downloaded from the website of Murata Manufacturing co., ltd. Therefore, it's specifications are subject to change or our products in it may be discontinued without advance notice. Please check with our sales representatives or product engineers before ordering.
2. This datasheet has only typical specifications because there is no space for detailed specifications. Therefore, please approve our product specifications or transact the approval sheet for product specifications before ordering.

## 12-5. Transportation

If you transport the products, please wrap-up in addition to the standard package. Otherwise mechanical vibrations or mechanical shocks, may damage the package and please direct transporters to handle with care. If you transport the products to overseas (in particular, by sea), it is expected that the transportation environment will be the worst. So please pack the products, in the package designed on the consideration of mechanical strength, vibration-resistant and humidity-resistant. The package of the products, which Murata sells in Japan, may not resist over seas transport. Please consult us if you are to use the standard package of the products sold in Japan for transport to overseas.

## 13. Production Factories

Komatsu Murata Mfg.Co.,Ltd.  
Wakura Murata Mfg.Co.,Ltd.  
Kanazu Murata Mfg.Co.,Ltd.

## Note

1. Against an unlikely event by abnormality or trouble of products, please give appropriate fail-safe function to it to prevent secondary disaster.
2. Please contact our sales representatives or product engineers before using our products for the applications listed below which require especially high reliability for the prevention of defects which might directly cause damage to the third party's life, body or property.
  1. Aircraft equipment
  2. Aerospace equipment
  3. Undersea equipment
  4. Atomic power plant equipment
  5. Medical equipment
  6. Transportation equipment (vehicles, trains, ships, etc.)
  7. Traffic signal equipment
  8. Disaster prevention / crime prevention equipment
  9. Data-processing equipment
  10. Application of similar complexity and/or reliability requirements to the applications listed in the above.

## Request to customer

1. Please evaluate the products mounted on your appliance.
2. Contents specified in the document are based on the preconditions of the purpose, condition and environment to which Murata has agreed with customers.  
Please do not use the products deviated from application described in the specification.
3. Please return two specifications with stamped or signature for your receipt.

We consider it not appropriate to include other terms and conditions for transaction warranty in product specifications, drawings or other technical documents. Therefore, if your technical documents as above include such terms and conditions as warranty clause, product liability clause, or intellectual property infringement liability clause, we will not be able to accept such terms and conditions unless they are based on the governmental regulation or they are stated in a separate contract agreement.

**The document is for reference only and is subject to revision without notices.  
Please contact Murata for formal documentation.**

## ⚠ Note:

1. This datasheet is downloaded from the website of Murata Manufacturing co., ltd. Therefore, it's specifications are subject to change or our products in it may be discontinued without advance notice. Please check with our sales representatives or product engineers before ordering.
2. This datasheet has only typical specifications because there is no space for detailed specifications. Therefore, please approve our product specifications or transact the approval sheet for product specifications before ordering.