

DC-DC Converter Specification

MP7D05*S

1 . Application

This specification applies to DC-DC Converter MPD7D05*S(*:2~8) for telecommunication / data-communication equipment.

For any other application, please contact us before using this product.

2 . Customer Reference

Customer Spec. Number

Customer Part Number

3 . Customer & Murata Part Number

Nominal Output Voltage [V]	Customer Part Number	Part Number
1.2V		MPD7D052S
1.5V		MPD7D053S
1.8V		MPD7D054S
2.5 V		MPD7D056S
3.3V		MPD7D057S
5.0V		MPD7D058S

⚠ Note:

1. This datasheet is downloaded from the website of Murata Manufacturing co., ltd. Therefore, it's specifications are subject to change or our products in it may be discontinued without advance notice. Please check with our sales representatives or product engineers before ordering.
2. This datasheet has only typical specifications because there is no space for detailed specifications. Therefore, please approve our product specifications or transact the approval sheet for product specifications before ordering.

4. Appearance, Dimensions
Objective Products MPD7D05*S (* : 2 · 3 · 4 · 6 · 7 · 8)

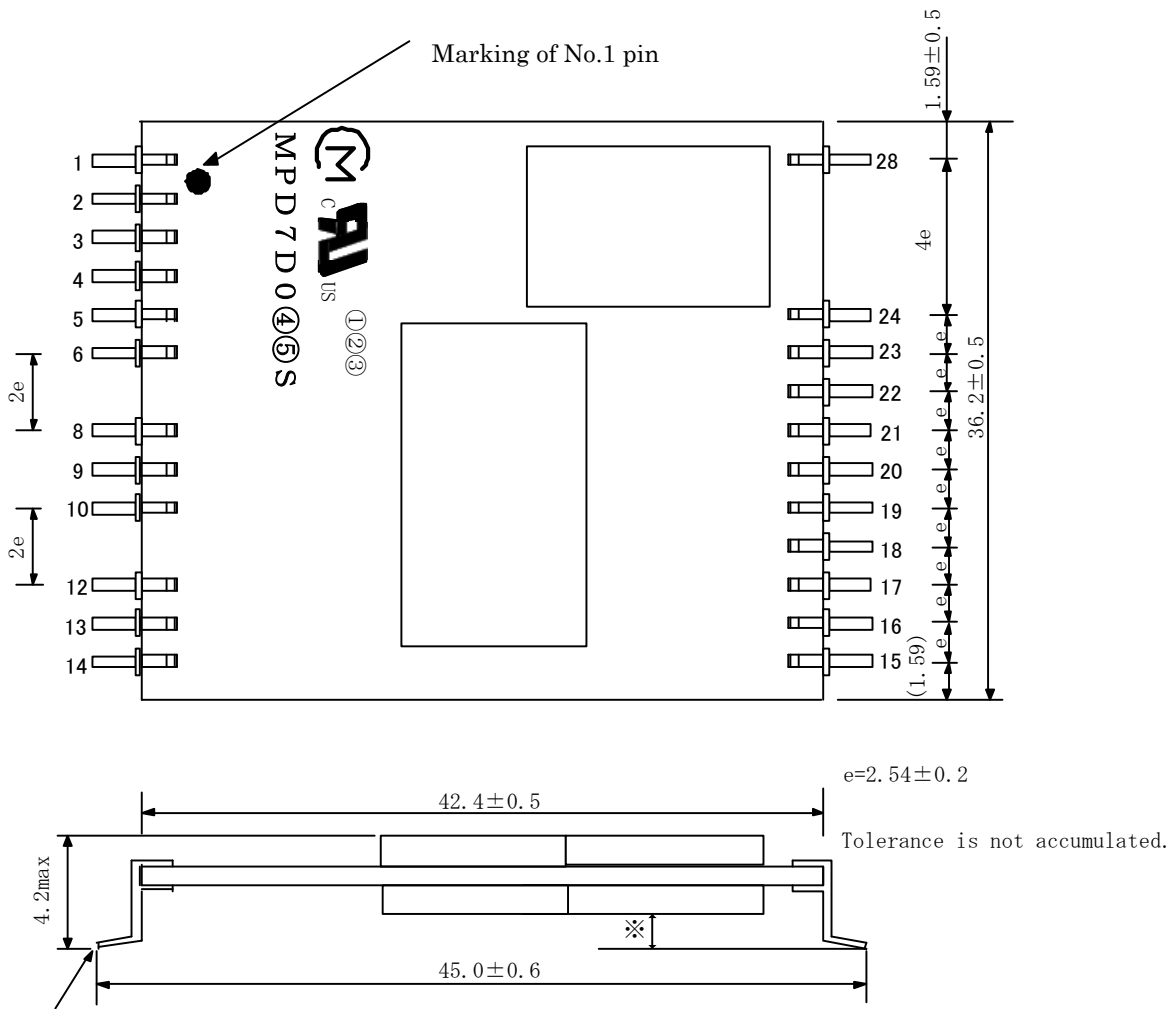

Coplanarity Max0.1

※Clearance of product bottom 0.08min

[unit: mm]

Marking

(1) MFG ID



(2) Lot No.



- ① Production factory Mark
- ② Production Year
- ③ Production Month (1,2,3,···9,O,N,D)

(3) Product Number

④⑤ Part number of underlined.

MPD7D05*S

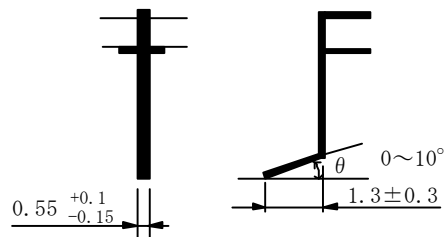

⚠ Note:

1. This datasheet is downloaded from the website of Murata Manufacturing co., ltd. Therefore, it's specifications are subject to change or our products in it may be discontinued without advance notice. Please check with our sales representatives or product engineers before ordering.
2. This datasheet has only typical specifications because there is no space for detailed specifications. Therefore, please approve our product specifications or transact the approval sheet for product specifications before ordering.

5. Pin Number and Function

Pin No.	Symbol	Function
1,28	NCo	One pin of two corners of PWB. For dipping resin to glue on backside of motherboard.
2	ALM	Alarm output to stop all in abnormality.
3	NC	
4	RC	Remote ON/OFF
5	NC	
6	PO	Parallel operation.
8	-Vin	(-)Input
9	-Vin	(-)Input
10	-Vin	(-)Input
12	+Vin	(+)Input
13	+Vin	(+)Input
14	+Vin	(+)Input
15	+Vout	(+)Output
16	+Vout	(+)Output
17	+Vout	(+)Output
18	+Vout	(+)Output
19	-Vout	(-)Output
20	-Vout	(-)Output
21	-Vout	(-)Output
22	-Vout	(-)Output
23	-Vout	(-)Output
24	-Vout	(-)Output

6. Block Diagram

6.1 Entire Product

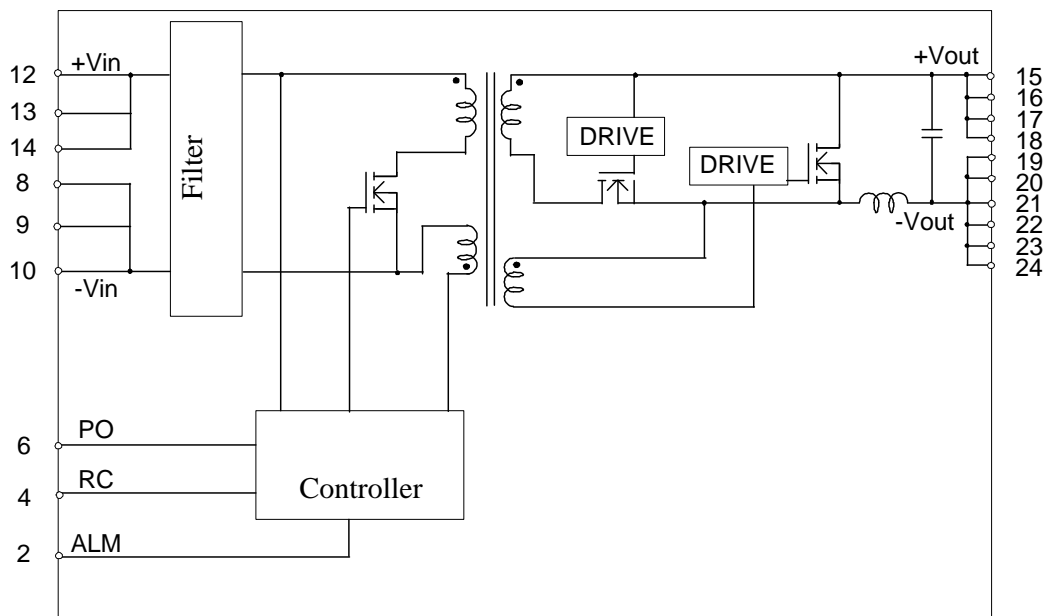

⚠ Note:

1. This datasheet is downloaded from the website of Murata Manufacturing co., Ltd. Therefore, it's specifications are subject to change or our products in it may be discontinued without advance notice. Please check with our sales representatives or product engineers before ordering.
2. This datasheet has only typical specifications because there is no space for detailed specifications. Therefore, please approve our product specifications or transact the approval sheet for product specifications before ordering.

7. Environmental Conditions

7.1	Operating Temperature Range	-40°C ~ +85°C (With power derated.)
7.2	Operating Humidity Range	20% ~ 85% (No water condenses.)
7.3	Storage Temperature Range	-45°C ~ +90°C
7.4	Storage Humidity Range	10% ~ 95%(No water condenses.)

8. Absolute Rating

Item			Unit	Absolute Rating	Remarks
Minimum Input Voltage			V	0	
Maximum Input Voltage ALM Applied Voltage RC Applied Voltage	Time	Continuous	V	75	
		200μs	V	90	Slew rate 42V/10μs
PO Applied Voltage			V	8	
Maximum ALM Sink Current			mA	10	

No voltage, no matter how instantaneous, shall be applied beyond the absolute maximum voltage rating to this product.

If you apply any voltage over this limit the product characteristics will deteriorate or the product itself will be destroyed.

Even though it may continue operating for a while after the over-voltage event, its life will likely be shortened significantly. Reliability and life of the module may degrade similarly if the maximum operating voltage rating is continuously exceeded. This product is designed to operate within the maximum operating voltage rating specification.

⚠ Note:

1. This datasheet is downloaded from the website of Murata Manufacturing co., ltd. Therefore, it's specifications are subject to change or our products in it may be discontinued without advance notice. Please check with our sales representatives or product engineers before ordering.
2. This datasheet has only typical specifications because there is no space for detailed specifications. Therefore, please approve our product specifications or transact the approval sheet for product specifications before ordering.

9. Characteristics

9.1 Electrical Characteristics (Ta=25°C)

9.1.1 General Characteristics

Unless otherwise specified, (Ta= -40 to +85°C with power derated.)

Item	Symbol	Condition	Value			Unit
			Min.	Typ.	Max.	
Input Voltage Range	Vin	Natural Air Convection Min 0.2m/s	36	48	75	V
Turn-on Input Voltage		Vin=increasing	32	-	36	V
Input Voltage difference of Turn-on and Turn-off		PO pin : Open or Connected to PO pin of other DC-DC Converters	2.0	-	-	V
Galvanic Isolation Voltage		Input time : 1 minute	1500	-	-	Vdc

Item	Standard	Note
Noise (Radiation, Conduction)	In accordance with VCCI Class A	Refer to Test Circuit in clause 10
Safety Standard	Recognized UL60950(UL/C-UL), Complied IEC 60950	UL file No.E190503
	CE Marking	CE Mark is shown on a package box.
Maximum Number of Parallel Operation	2 to 5 pcs	Refer to specific power derating.

Note 1 : Please connect an external input filter to the product input pins for input chattering expected in application.

⚠ Note:

1. This datasheet is downloaded from the website of Murata Manufacturing co., ltd. Therefore, it's specifications are subject to change or our products in it may be discontinued without advance notice. Please check with our sales representatives or product engineers before ordering.
2. This datasheet has only typical specifications because there is no space for detailed specifications. Therefore, please approve our product specifications or transact the approval sheet for product specifications before ordering.

9.1.2 Specific Characteristics (Ta= -40 to +85°C with power derated.)

Part Number		MPD7D052S				
Item	Symbol	Condition	Value			Unit
			Min.	Typ.	Max.	
Nominal Output Voltage	Vo		-	1.2	-	V
Output Voltage Variation	Δregtot	Vin=36 to 75V, Io=0 to 16A Ta=-40 to +85°C	-3		+5	%
Output Current	Io	Power derated.	0	-	16	A
Efficiency	η	at rated Vin, Io, Ta=25°C	-	86	-	%
Ripple Voltage	Vr	Refer to Test Circuit	-	-	50	mVpp
Ripple Voltage & Noise			-	-	100	
Over Current Protection	Iocp		16.5	-	-	A
Over Voltage Protection	Vovp	Output halts in latch-up mode after mask time 0.5msec (typ) to avoid malfunction by noise and transient change. Input turn off and on to reset.	1.44	-	-	V
Low Voltage Protection	Vlvp	Output halts in latch-up mode after mask time 500msec (typ) to avoid malfunction by noise and transient change. Input turn off and on to reset.	-	-	1.08	V

**Caution**

The above electrical characteristics are guaranteed in the condition that the impedance of the input power supply is sufficiently low as shown in clause 10.

Connecting an input inductance or using an input power supply with output inductance may cause an unstable operation of this product. Please check the proper operation of this product with the peripheral circuits on your product.

Note:

1. This datasheet is downloaded from the website of Murata Manufacturing co., ltd. Therefore, it's specifications are subject to change or our products in it may be discontinued without advance notice. Please check with our sales representatives or product engineers before ordering.
2. This datasheet has only typical specifications because there is no space for detailed specifications. Therefore, please approve our product specifications or transact the approval sheet for product specifications before ordering.

9.1.3 Specific Characteristics (Ta= -40 to +85°C with power derated.)

Part Number		MPD7D053S				
Item	Symbol	Condition	Value			Unit
			Min.	Typ.	Max.	
Nominal Output Voltage	Vo		-	1.5	-	V
Output Voltage Variation	Δ regtot	Vin=36 to 75V, Io=0 to 17A Ta=-40 to +85°C	-3		+5	%
Output Current	Io	Power derated.	0	-	17	A
Efficiency	η	at rated Vin, Io, Ta=25°C	-	84	-	%
Ripple Voltage	Vr	Refer to Test Circuit	-	-	50	mVpp
Ripple Voltage & Noise			-	-	100	
Over Current Protection	Iocp		17.5	-	-	A
Over Voltage Protection	Vovp	Output halts in latch-up mode after mask time 0.5msec (typ) to avoid malfunction by noise and transient change. Input turn off and on to reset.	1.8	-	-	V
Low Voltage Protection	Vlvp	Output halts in latch-up mode after mask time 500msec (typ) to avoid malfunction by noise and transient change. Input turn off and on to reset.	-	-	1.35	V

 Caution

The above electrical characteristics are guaranteed in the condition that the impedance of the input power supply is sufficiently low as shown in clause 10.

Connecting an input inductance or using an input power supply with output inductance may cause an unstable operation of this product. Please check the proper operation of this product with the peripheral circuits on your product.

 Note:

1. This datasheet is downloaded from the website of Murata Manufacturing co., Ltd. Therefore, it's specifications are subject to change or our products in it may be discontinued without advance notice. Please check with our sales representatives or product engineers before ordering.
2. This datasheet has only typical specifications because there is no space for detailed specifications. Therefore, please approve our product specifications or transact the approval sheet for product specifications before ordering.

9.1.4 Specific Characteristics (Ta= -40 to +85°C with power derated.)

Part Number		MPD7D054S				
Item	Symbol	Condition	Value			Unit
			Min.	Typ.	Max.	
Nominal Output Voltage	Vo		-	1.8	-	V
Output Voltage Variation	Δ regtot	Vin=36 to 75V, Io=0 to 15A Ta=-40 to +85°C	-3		+5	%
Output Current	Io	Power derated.	0	-	16	A
Efficiency	η	at rated Vin, Io, Ta=25°C	-	86	-	%
Ripple Voltage	Vr	Refer to Test Circuit	-	-	50	mVpp
Ripple Voltage & Noise			-	-	100	
Over Current Protection	Iocp		16.5	-	-	A
Over Voltage Protection	Vovp	Output halts in latch-up mode after mask time 0.5msec (typ) to avoid malfunction by noise and transient change. Input turn off and on to reset.	2.16	-	-	V
Low Voltage Protection	Vlvp	Output halts in latch-up mode after mask time 500msec (typ) to avoid malfunction by noise and transient change. Input turn off and on to reset.	-	-	1.62	V

**Caution**

The above electrical characteristics are guaranteed in the condition that the impedance of the input power supply is sufficiently low as shown in clause 10. Connecting an input inductance or using an input power supply with output inductance may cause an unstable operation of this product. Please check the proper operation of this product with the peripheral circuits on your product.

Note:

1. This datasheet is downloaded from the website of Murata Manufacturing co., ltd. Therefore, it's specifications are subject to change or our products in it may be discontinued without advance notice. Please check with our sales representatives or product engineers before ordering.
2. This datasheet has only typical specifications because there is no space for detailed specifications. Therefore, please approve our product specifications or transact the approval sheet for product specifications before ordering.

9.1.5. Specific Characteristics (Ta= -40 to +85°C with power derated.)

Part Number		MPD7D056S				
Item	Symbol	Condition	Value			Unit
			Min.	Typ.	Max.	
Nominal Output Voltage	Vo		-	2.5	-	V
Output Voltage Variation	Δ regtot	Vin=36 to 75V, Io=0 to 15A Ta=-40 to +85°C	-3		+5	%
Output Current	Io	Power derated.	0	-	15	A
Efficiency	η	at rated Vin, Io, Ta=25°C	-	89	-	%
Ripple Voltage	Vr	Refer to Test Circuit	-	-	50	mVpp
Ripple Voltage & Noise			-	-	100	
Over Current Protection	Iocp		15.4	-	-	A
Over Voltage Protection	Vovp	Output halts in latch-up mode after mask time 0.5msec (typ) to avoid malfunction by noise and transient change. Input turn off and on to reset.	3.0	-	-	V
Low Voltage Protection	Vlvp	Output halts in latch-up mode after mask time 500msec (typ) to avoid malfunction by noise and transient change. Input turn off and on to reset.	-	-	2.25	V

**Caution**

The above electrical characteristics are guaranteed in the condition that the impedance of the input power supply is sufficiently low as shown in clause 10.

Connecting an input inductance or using an input power supply with output inductance may cause an unstable operation of this product. Please check the proper operation of this product with the peripheral circuits on your product.

Note:

1. This datasheet is downloaded from the website of Murata Manufacturing co., Ltd. Therefore, it's specifications are subject to change or our products in it may be discontinued without advance notice. Please check with our sales representatives or product engineers before ordering.
2. This datasheet has only typical specifications because there is no space for detailed specifications. Therefore, please approve our product specifications or transact the approval sheet for product specifications before ordering.

9.1.6 Specific Characteristics (Ta= -40 to +85°C with power derated.)

Part Number		MPD7D057S				
Item	Symbol	Condition	Value			Unit
			Min.	Typ.	Max.	
Nominal Output Voltage	Vo		-	3.3	-	V
Output Voltage Variation	Δ regtot	Vin=36 to 75V, Io=0 to 15A Ta=-40 to +85°C	-3		+5	%
Output Current	Io	Power derated.	0	-	15	A
Efficiency	η	at rated Vin, Io, Ta=25°C	-	90	-	%
Ripple Voltage	Vr	Refer to Test Circuit	-	-	50	mVpp
Ripple Voltage & Noise			-	-	100	
Over Current Protection	Iocp		15.4	-	-	A
Over Voltage Protection	Vovp	Output halts in latch-up mode after mask time 0.5msec (typ) to avoid malfunction by noise and transient change. Input turn off and on to reset.	3.96	-	-	V
Low Voltage Protection	Vlvp	Output halts in latch-up mode after mask time 500msec (typ) to avoid malfunction by noise and transient change. Input turn off and on to reset.	-	-	2.97	V

**Caution**

The above electrical characteristics are guaranteed in the condition that the impedance of the input power supply is sufficiently low as shown in clause 10.

Connecting an input inductance or using an input power supply with output inductance may cause an unstable operation of this product. Please check the proper operation of this product with the peripheral circuits on your product.

Note:

1. This datasheet is downloaded from the website of Murata Manufacturing co., Ltd. Therefore, it's specifications are subject to change or our products in it may be discontinued without advance notice. Please check with our sales representatives or product engineers before ordering.
2. This datasheet has only typical specifications because there is no space for detailed specifications. Therefore, please approve our product specifications or transact the approval sheet for product specifications before ordering.

9.1.7 Specific Characteristics (Ta= -40 to +85°C with power derated.)

Part Number		MPD7D058S				
Item	Symbol	Condition	Value			Unit
			Min.	Typ.	Max.	
Nominal Output Voltage	Vo		-	5.0	-	V
Output Voltage Variation	Δregtot	Vin=36 to 75V, Io=0 to 10A Ta=-40 to +85°C	-3		+5	%
Output Current	Io	Power derated.	0	-	10	A
Efficiency	η	at rated Vin, Io, Ta=25°C	-	90	-	%
Ripple Voltage	Vr	Refer to Test Circuit	-	-	50	mVpp
Ripple Voltage & Noise			-	-	100	
Over Current Protection	Iocp		10.3	-	-	A
Over Voltage Protection	Vovp	Output halts in latch-up mode after mask time 0.5msec (typ) to avoid malfunction by noise and transient change. Input turn off and on to reset.	6.0	-	-	V
Low Voltage Protection	Vlvp	Output halts in latch-up mode after mask time 500msec (typ) to avoid malfunction by noise and transient change. Input turn off and on to reset.	-	-	4.5	V

**Caution**

The above electrical characteristics are guaranteed in the condition that the impedance of the input power supply is sufficiently low as shown in clause 10.

Connecting an input inductance or using an input power supply with output inductance may cause an unstable operation of this product. Please check the proper operation of this product with the peripheral circuits on your product.

Note:

1. This datasheet is downloaded from the website of Murata Manufacturing co., ltd. Therefore, it's specifications are subject to change or our products in it may be discontinued without advance notice. Please check with our sales representatives or product engineers before ordering.
2. This datasheet has only typical specifications because there is no space for detailed specifications. Therefore, please approve our product specifications or transact the approval sheet for product specifications before ordering.

Power Derating MPD7D052S < For Reference Only >

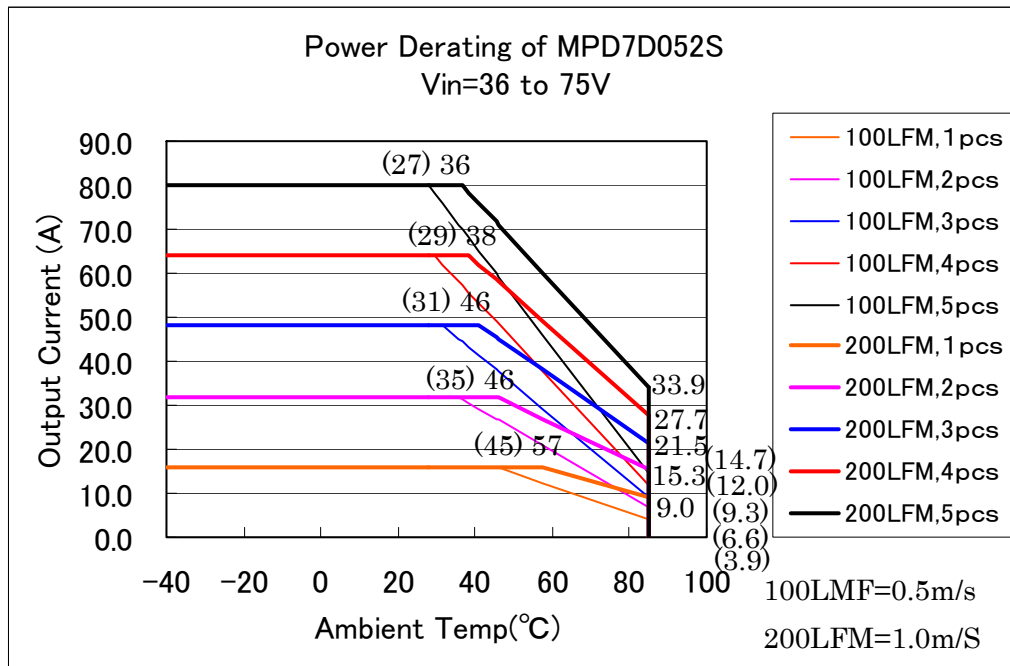

<Notice>

We would like to emphasize that these data are based on our experimental measurement. Please confirm that the maximum temperature of components mounted on a DC-DC Converter is 120°C or less in your application. For parallel operation, Please equalize line impedance from each of DC-DC Converters.

⚠ Note:

1. This datasheet is downloaded from the website of Murata Manufacturing co., ltd. Therefore, it's specifications are subject to change or our products in it may be discontinued without advance notice. Please check with our sales representatives or product engineers before ordering.
2. This datasheet has only typical specifications because there is no space for detailed specifications. Therefore, please approve our product specifications or transact the approval sheet for product specifications before ordering.

Power Derating MPD7D053S < For Reference Only >

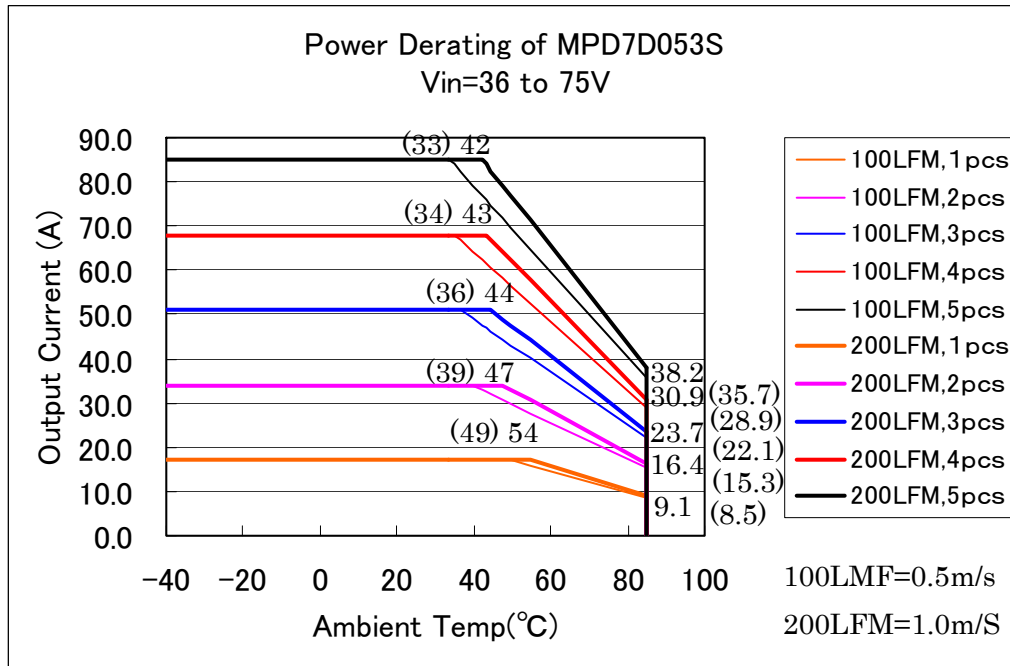

<Notice>

We would like to emphasize that these data are based on our experimental measurement. Please confirm that the maximum temperature of components mounted on a DC-DC Converter is 120°C or less in your application. For parallel operation, Please equalize line impedance from each of DC-DC Converters.

⚠ Note:

1. This datasheet is downloaded from the website of Murata Manufacturing co., ltd. Therefore, it's specifications are subject to change or our products in it may be discontinued without advance notice. Please check with our sales representatives or product engineers before ordering.
2. This datasheet has only typical specifications because there is no space for detailed specifications. Therefore, please approve our product specifications or transact the approval sheet for product specifications before ordering.

Power Derating MPD7D054S < For Reference Only >

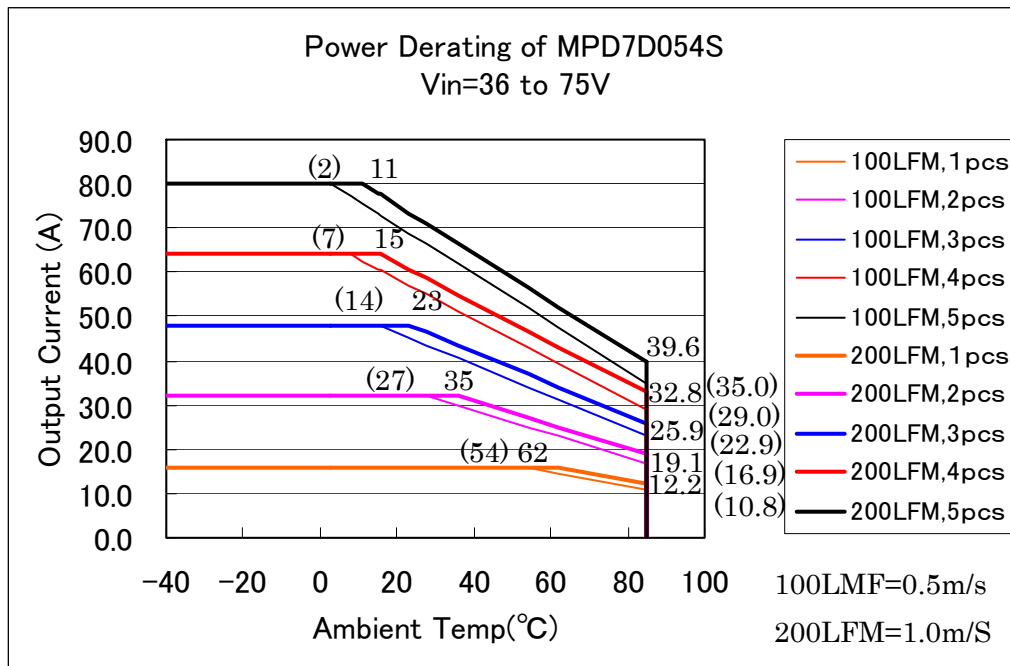

<Notice>

We would like to emphasize that these data are based on our experimental measurement.

Please confirm that the maximum temperature of components mounted on a DC-DC Converter is 120°C or less in your application.

For parallel operation, Please equalize line impedance from each of DC-DC Converters.

⚠ **Note:**

1. This datasheet is downloaded from the website of Murata Manufacturing co., ltd. Therefore, it's specifications are subject to change or our products in it may be discontinued without advance notice. Please check with our sales representatives or product engineers before ordering.
2. This datasheet has only typical specifications because there is no space for detailed specifications. Therefore, please approve our product specifications or transact the approval sheet for product specifications before ordering.

Power Derating MPD7D056S < For Reference Only >

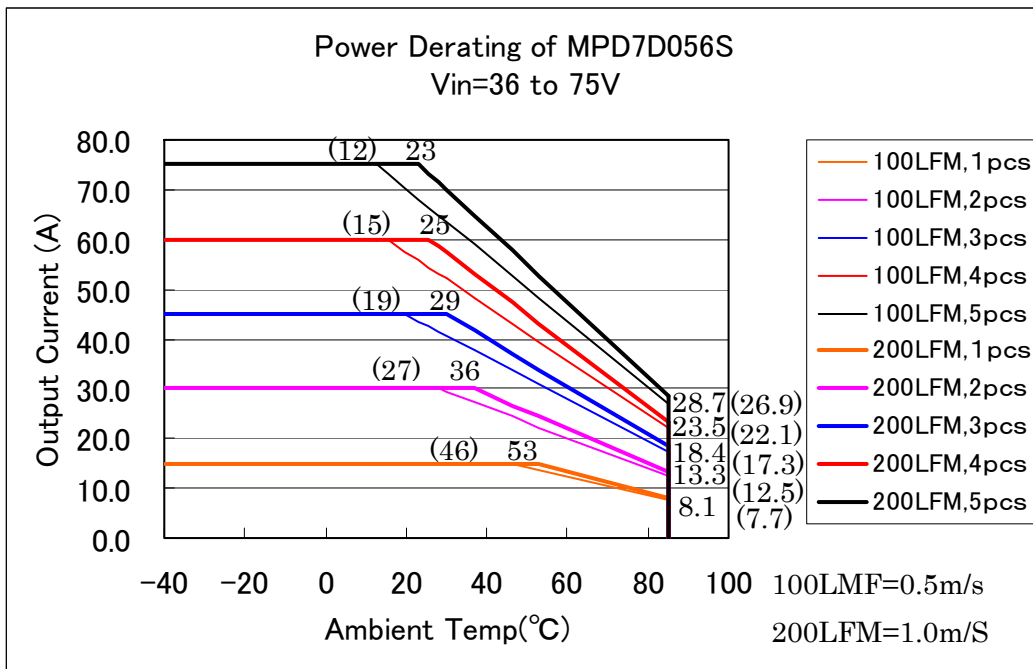

<Notice>

We would like to emphasize that these data are based on our experimental measurement. Please confirm that the maximum temperature of components mounted on a DC-DC Converter is 120°C or less in your application. For parallel operation, Please equalize line impedance from each of DC-DC Converters.

⚠ Note:

1. This datasheet is downloaded from the website of Murata Manufacturing co., ltd. Therefore, it's specifications are subject to change or our products in it may be discontinued without advance notice. Please check with our sales representatives or product engineers before ordering.
2. This datasheet has only typical specifications because there is no space for detailed specifications. Therefore, please approve our product specifications or transact the approval sheet for product specifications before ordering.

Power Derating MPD7D057S < For Reference Only >

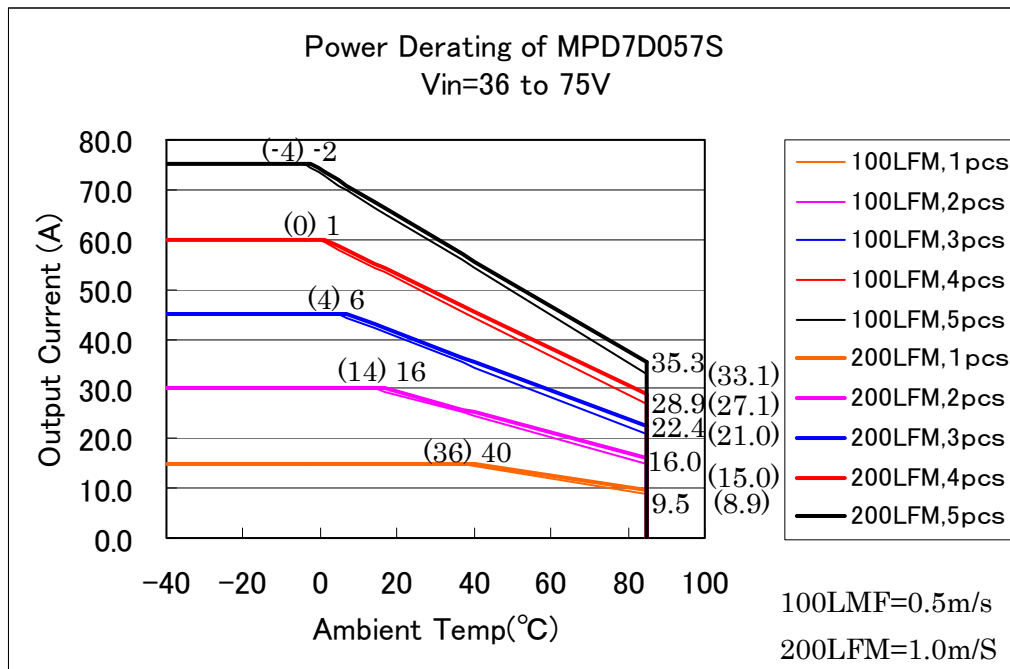

<Notice>

We would like to emphasize that these data are based on our experimental measurement. Please confirm that the maximum temperature of components mounted on a DC-DC Converter is 120°C or less in your application.
For parallel operation, Please equalize line impedance from each of DC-DC Converters.

⚠ Note:

1. This datasheet is downloaded from the website of Murata Manufacturing co., Ltd. Therefore, it's specifications are subject to change or our products in it may be discontinued without advance notice. Please check with our sales representatives or product engineers before ordering.
2. This datasheet has only typical specifications because there is no space for detailed specifications. Therefore, please approve our product specifications or transact the approval sheet for product specifications before ordering.

Power Derating MPD7D058S < For Reference Only >

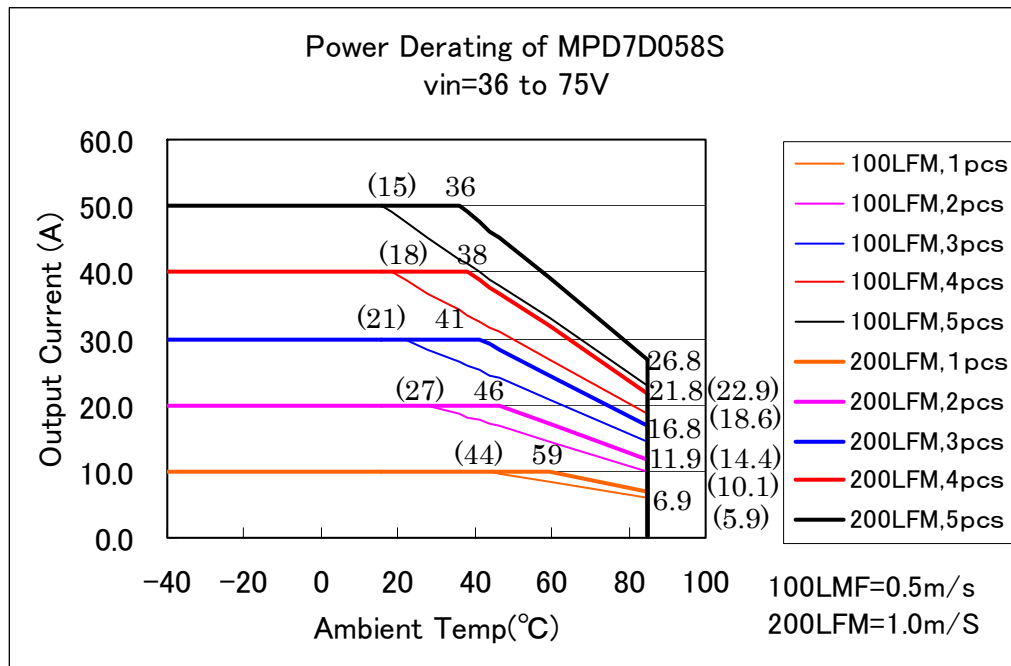

<Notice>

We would like to emphasize that these data are based on our experimental measurement. Please confirm that the maximum temperature of components mounted on a DC-DC Converter is 120°C or less in your application. For parallel operation, Please equalize line impedance from each of DC-DC Converters.

⚠ **Note:**

1. This datasheet is downloaded from the website of Murata Manufacturing co., Ltd. Therefore, it's specifications are subject to change or our products in it may be discontinued without advance notice. Please check with our sales representatives or product engineers before ordering.
2. This datasheet has only typical specifications because there is no space for detailed specifications. Therefore, please approve our product specifications or transact the approval sheet for product specifications before ordering.

9. 2 Operation information

9. 2. 1 Reset Condition

In order to reset all function, the input Voltage is set under 5V for Min.1 second.

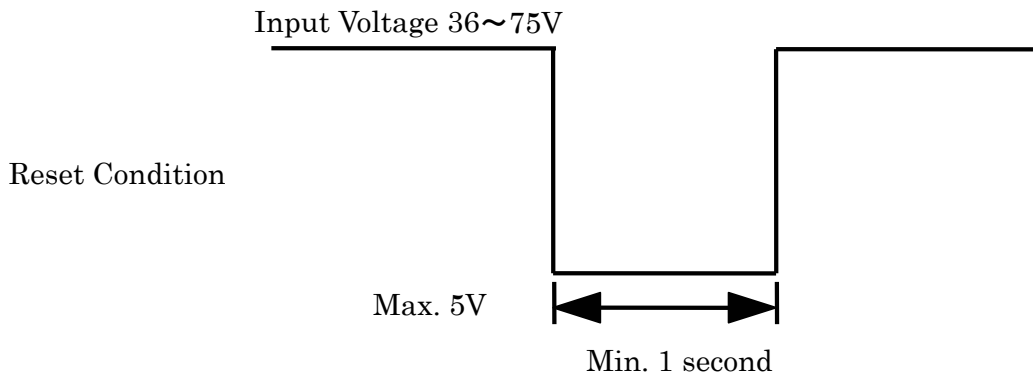

9. 2. 2 Over Voltage Protection

Output halts in latch-up mode after 0.5msec(typ) mask time while Output Voltage is over the value of over voltage protection specified in 9.1. clause with failure of controller circuit.

Output will re-start after input turns off for Min. 1 second with input voltage less than 5V.

Output voltage might exceed the point at over voltage protection under the specific condition of transient change of input voltage or output load, in this condition over voltage protection wait its start until the mask time.

It is recommended to evaluate your appliance installed with DC-DC converter.

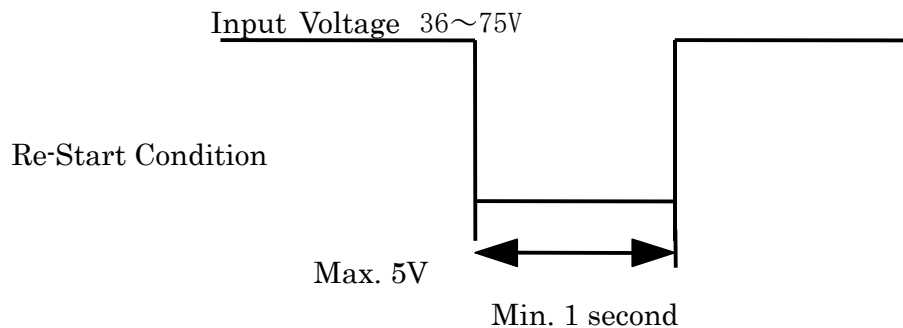

⚠ Note:

1. This datasheet is downloaded from the website of Murata Manufacturing co., ltd. Therefore, it's specifications are subject to change or our products in it may be discontinued without advance notice. Please check with our sales representatives or product engineers before ordering.
2. This datasheet has only typical specifications because there is no space for detailed specifications. Therefore, please approve our product specifications or transact the approval sheet for product specifications before ordering.

9. 2. 3 Low Voltage Protection

Output halts in latch-up mode after 500msec(typ) mask time while output voltage is below the value of low voltage protection specified in 9.1 clause with failure of controller circuit or over load condition. Output will re-start after input turns off for Min.1 second with input voltage less than 5V.

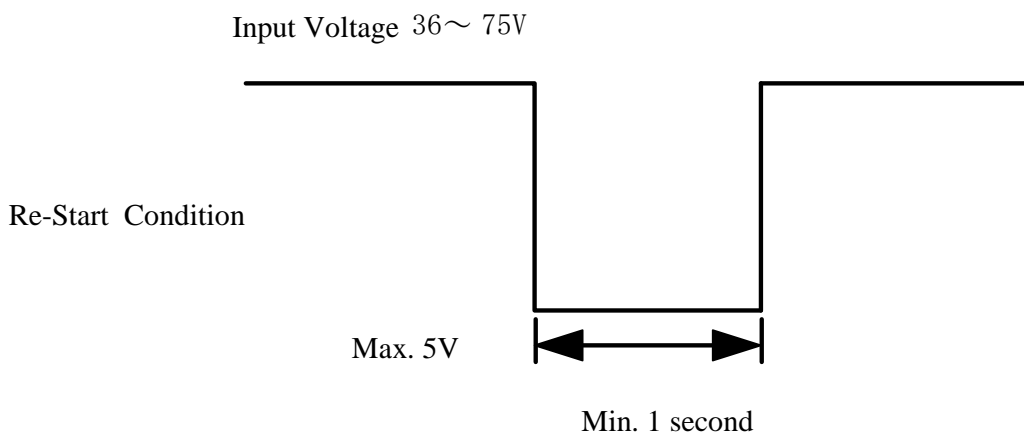

9. 2. 4 Remote On/Off Control

Start and halt is possible with a control signal.

While the control signal stops output from DC-DC converter, alarm output does not send any signal.

Start : RC is open or connected to-Vin.

Halt : RC is connected to +Vin.

9. 2. 5 Alarm Output

ALM pin is down to the same voltage level of-Vin pin and sends an alarm signal. (open-drain output)

Sink current in ALM pin is Max.10mA.

It is possible to halt all of the connected DC-DC converters when any one is halted with over voltage protection or low voltage protection, with connecting all ALM pins for the application of parallel/multiple operation (Note 3) with plural DC-DC converters.

The maximum number connecting DC-DC converters is 5pcs of parallel operation, 10pcs of multiple operation, for the purpose of halting all DC-DC converters connected with ALM pin each other. Please contact us when more than these figures.

Note 3 The parallel operation of this series is limited to only the same model.

9. 2. 6 Synchronous Turn-on/off

It is possible to avoid the unevenness of turn-on timing with unifying the various Turn-on input voltage to a certain voltage which one DC-DC converter has, and with connecting PO pins each other for the application of parallel/multiple operation (Note 3) of plural DC-DC converters.

It is necessary to connect PO pins for parallel operation.

The maximum number connecting DC-DC converters is 5pcs of parallel operation, 10pcs of multiple operation, for the purpose of synchronous turn-on/off with connecting PO pins.

Please contact us when more than these figures.

Note 3 The parallel operation of this series is limited to only the same model.

⚠ Note:

1. This datasheet is downloaded from the website of Murata Manufacturing co., Ltd. Therefore, it's specifications are subject to change or our products in it may be discontinued without advance notice. Please check with our sales representatives or product engineers before ordering.
2. This datasheet has only typical specifications because there is no space for detailed specifications. Therefore, please approve our product specifications or transact the approval sheet for product specifications before ordering.

9. 3 Reliability

9. 3. 1 Humidity Test

Parts are subjected to a temperature $40^{\circ}\text{C} \pm 2^{\circ}\text{C}$ with 90~95% for 100 hours.
Return the parts to room temperature (25°C) for 4 hours and measure. The initial values under item 9-1 should be met. (JIS-C-0022)

9. 3. 2 Thermal Cycle Test

Parts are subjected to 5 cycle of the following.
The parts are placed in room temperature (25°C) for 2 hours and are measured.
The initial values under item 9-1 should be met.

Step	Condition	Time
1	$-40 \pm 3^{\circ}\text{C}$	30 minutes
2	Room Temp.	5~10 minutes
3	$+85 \pm 3^{\circ}\text{C}$	30 minutes
4	Room Temp.	5~10 minutes

9. 3. 3 Vibration

Vibration Frequency : 10~55Hz

Amplitude : 1.5mm max.

10 to 55Hz, 1.5mm amplitude, 1 hour for each each of X,Y,Z directions.
No damage in appearance and no deviation from electrical characteristics(9-1).

9. 3. 4 Mechanical Shock

20G, 1 time for each X,Y,Z directions.
No damage in appearance and no deviation from electrical characteristics(9-1).

9. 3. 5 Soldering Heat Resistance

Immerse the part of lead where it is to be soldered on a motherboard in a solder bath of $260 \pm 5^{\circ}\text{C}$ for 3 ± 0.5 s.
Then tested products are left for 2 hours.
There is no damage in appearance and no deviation from electrical characteristics in clause 9.

9. 3. 6 Solderability of Leads

The lead pins will be immersed in the Isopropyl Alcohol (JIS K 1522) with Rosin (JIS K5902) solution (the concentration of Rosin will be allowed 10wt% to 35wt%, and normally approx. 25wt% will be used without any specific requirement.)
Then the lead pins will be immersed in the solder H63A (JIS Z 3282) solution at the temperature of $230^{\circ}\text{C} \pm 5^{\circ}\text{C}$ for 3 ± 0.5 seconds, and pulled up completely.
The solder will adhere to over 75% of immersed area.

⚠ Note:

1. This datasheet is downloaded from the website of Murata Manufacturing co., ltd. Therefore, it's specifications are subject to change or our products in it may be discontinued without advance notice. Please check with our sales representatives or product engineers before ordering.
2. This datasheet has only typical specifications because there is no space for detailed specifications. Therefore, please approve our product specifications or transact the approval sheet for product specifications before ordering.

10. Test Circuit

In the following test circuit, the measured values should meet those of clause 9.

10.1 General Measure Circuit

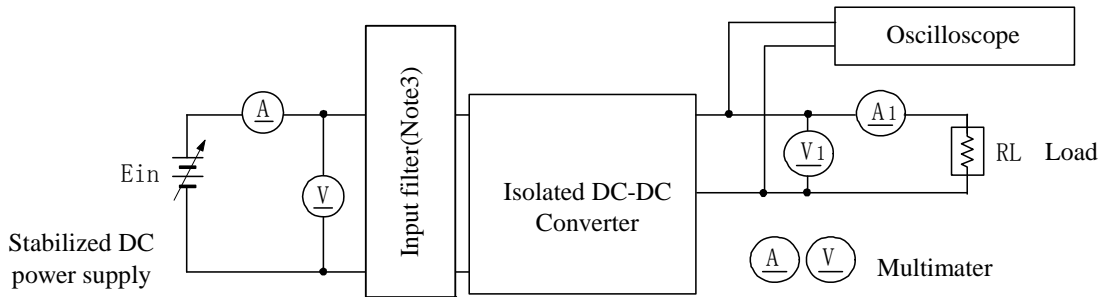

(Note 3) Please use the external input filter (See in clause 10-1-4) for input chattering expected in evaluation.

10.1.1 Output Ripple & Noise

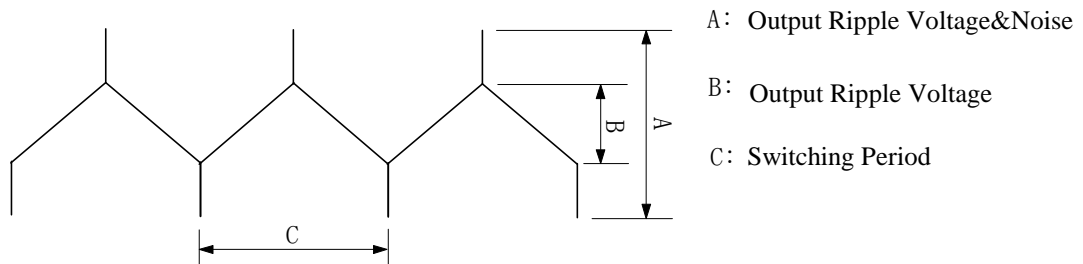
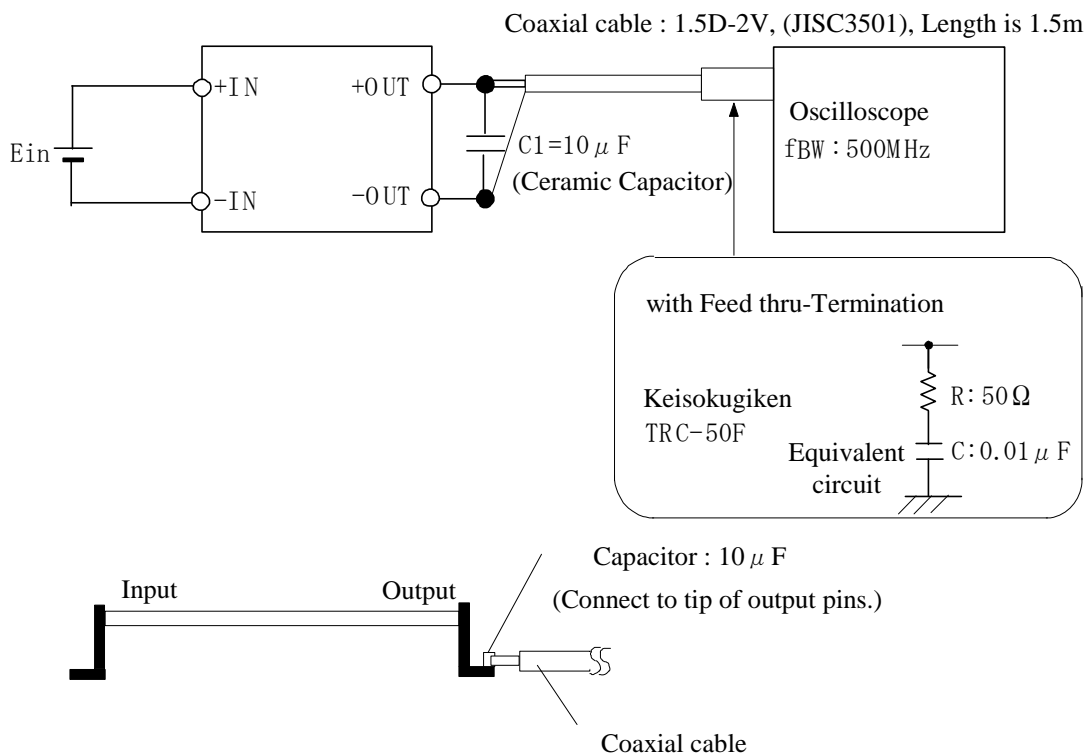

⚠ Note:

1. This datasheet is downloaded from the website of Murata Manufacturing co., ltd. Therefore, it's specifications are subject to change or our products in it may be discontinued without advance notice. Please check with our sales representatives or product engineers before ordering.
2. This datasheet has only typical specifications because there is no space for detailed specifications. Therefore, please approve our product specifications or transact the approval sheet for product specifications before ordering.

10.1.2 Radiation Noise

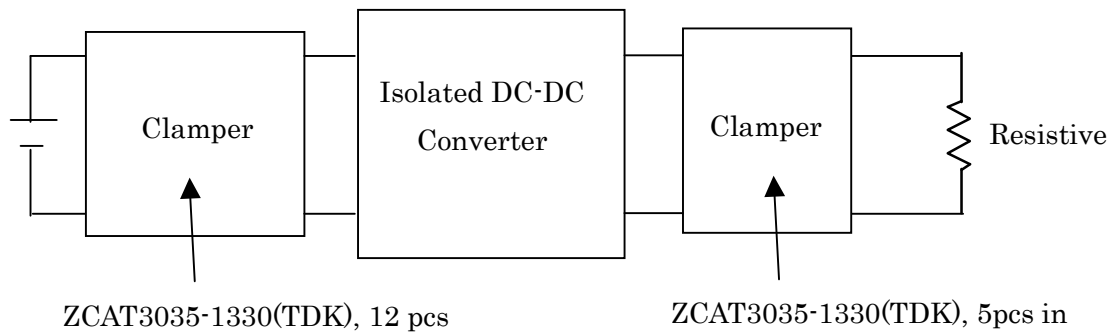

10.1.3 Conduction Noise

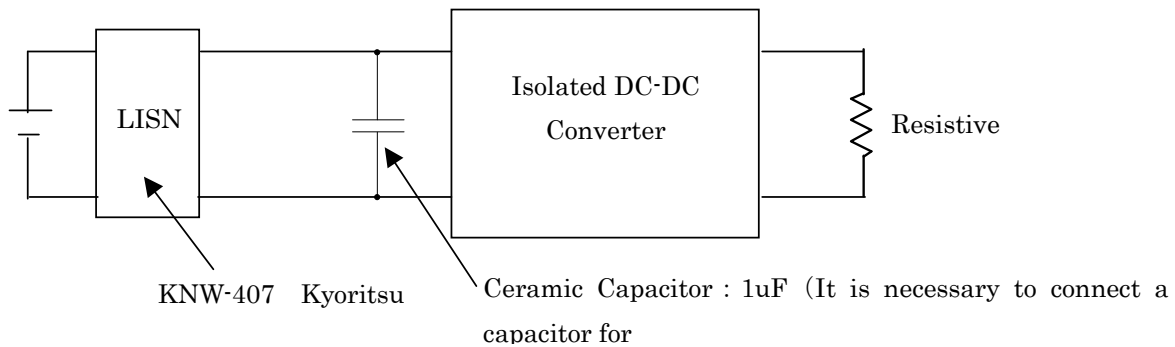

Measurement at Radiation Noise, Conductive Noise, Output ripple & Noise.

Please measure Radiation Noise, Conductive Noise and Output ripple & Noise with conforming to the Test Circuit in clause 10

Otherwise the noise might not meet the specified values.

10.1.4 External input filter

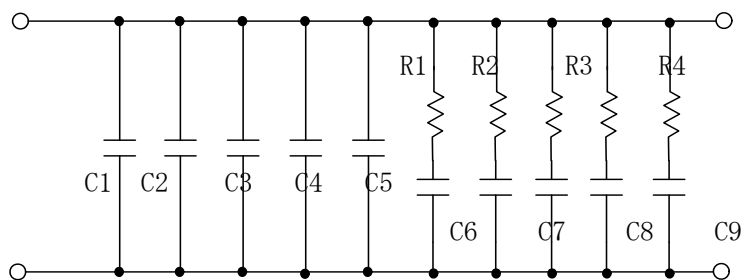

C1~C10 : 4.7 μ F

R1~R5 : 82 Ω

⚠ **Note:**

1. This datasheet is downloaded from the website of Murata Manufacturing co., ltd. Therefore, it's specifications are subject to change or our products in it may be discontinued without advance notice. Please check with our sales representatives or product engineers before ordering.
2. This datasheet has only typical specifications because there is no space for detailed specifications. Therefore, please approve our product specifications or transact the approval sheet for product specifications before ordering.

11. Packaging Information

11.1 Tray Dimensions

DC-DC Converters are put in the trays. (See Fig.1)

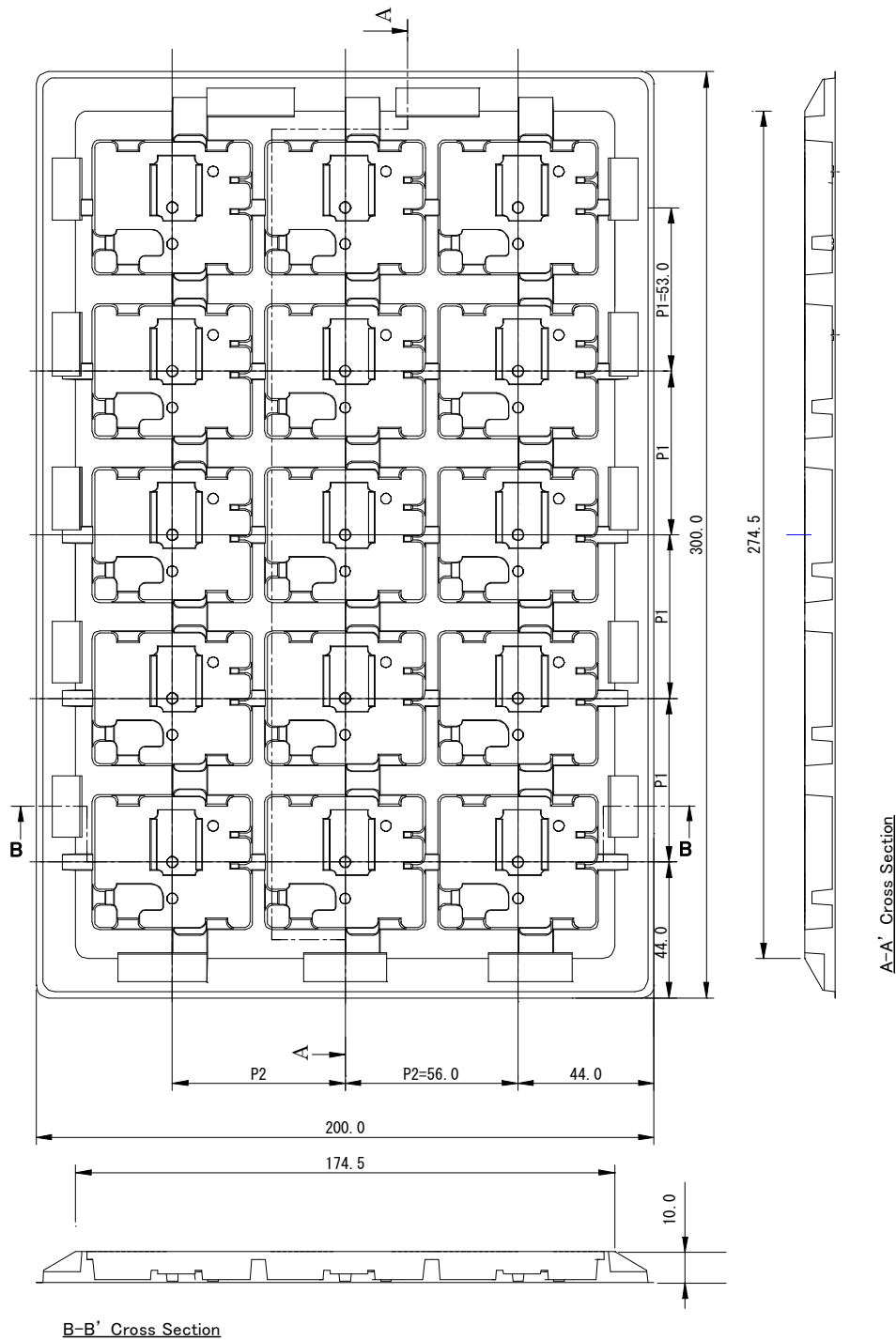

Fig.1

⚠ **Note:**

1. This datasheet is downloaded from the website of Murata Manufacturing co., Ltd. Therefore, it's specifications are subject to change or our products in it may be discontinued without advance notice. Please check with our sales representatives or product engineers before ordering.
2. This datasheet has only typical specifications because there is no space for detailed specifications. Therefore, please approve our product specifications or transact the approval sheet for product specifications before ordering.

11.2 Contained pieces of products per corrugated box.

Maximum Contained products pieces 90 pcs/corrugated box.

Further plural sheets of corrugated cardboard are placed on the top of the dummy tray according to number of contained trays in order to full up the space in a corrugated box.

11.3 Packaging Form

Trays with products are lidded and packed in a corrugated box. (See Fig.2)

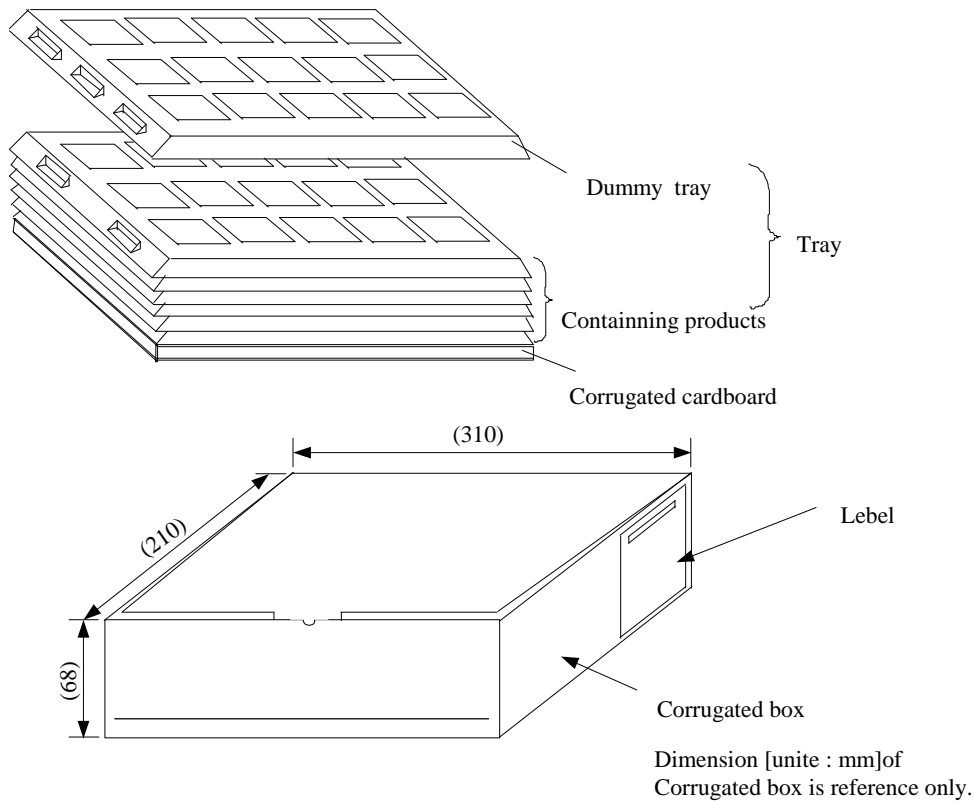

Fig.2

Marking on the box

1. MURATA Parts Number
2. Quantity
3. Inspection No.
4. CE Mark

⚠ Note:

1. This datasheet is downloaded from the website of Murata Manufacturing co., ltd. Therefore, it's specifications are subject to change or our products in it may be discontinued without advance notice. Please check with our sales representatives or product engineers before ordering.
2. This datasheet has only typical specifications because there is no space for detailed specifications. Therefore, please approve our product specifications or transact the approval sheet for product specifications before ordering.

12. Production factory

Komatsu Murata Mfg.Co.,Ltd.
Wakura Murata Mfg. Co., Ltd.
Kanazu Murata Mfg.Co.,Ltd.

 Caution

- 1 . Be sure to provide an appropriate fail-safe function on your product to prevent secondary damage that may be caused by the functional trouble or the failure of this product.
- 2 . Please contact us before using this product for the applications listed below which require especially high reliability for the prevention of defects and failure , which might directly cause damage to the third party's life, body or property.
 - ①Aircraft equipment
 - ②Aerospace equipment
 - ③Undersea equipment
 - ④Power plant control equipment
 - ⑤Medical equipment
 - ⑥Transportation equipment (vehicles, trains, ships, etc.)
 - ⑦Traffic signal equipment
 - ⑧Disaster prevention /crime prevention equipment
 - ⑨Any other application of similar complexity and/or reliability requirements to the applications listed above.

 Notice

- 1 . Please make sure that the evaluation and testing are completed with this product actually assembled on your product.
- 2 . All the items and parameters in this product specification have been prescribed on the premise that our product is used for the purpose, under the condition and in the environment mutually agreed upon. Please do not to use this product deviating from such agreement.
- 3 . We consider it not appropriate to include other terms and conditions for transaction warranty in product specifications, drawings or other technical documents. Therefore, if your technical documents include such terms and conditions as warranty clause, product liability clause, or intellectual property infringement liability clause, we will not be able to accept such terms and conditions unless they are based on the governmental regulation or they are stated in a separate contract agreement.
- 4 . Please return one duplicate of this product specification to us with your receipt signature. If the duplicates are not returned by Oct.28.2005, this product specification will be deemed to have been received by you.

 **Note:**

1. This datasheet is downloaded from the website of Murata Manufacturing co., ltd. Therefore, it's specifications are subject to change or our products in it may be discontinued without advance notice. Please check with our sales representatives or product engineers before ordering.
2. This datasheet has only typical specifications because there is no space for detailed specifications. Therefore, please approve our product specifications or transact the approval sheet for product specifications before ordering.

13. Notice

13. 1 Soldering

13.1. 1 Flux

Please solder this product with Rosin Flux, which contains of 0.2wt%. or less chlorine.
Please do not use high activity acid flux or water soluble flux because they may erode metal or glass portion of this product and may cause defectiveness or deterioration of this product.

13.1. 2 Solder

Please use the solder H60, H63(JIS Z3282)or the equivalent type.
Please use the solder paste of equivalent type H60, H63.

13.1. 3 Recommended Soldering Conditions

Re-flow Solder

Eutectic Solder

Please solder under the following condition.

Method	: Infrared ray reflow soldering
Soldering temperature	: 230°C max. (Parts surface temperature)
Soldering time	: 30 seconds max. (Over 200°C)
Preheating	: 60~120 seconds(140~160°C)
Time	: Maximum 2times

- ※ The solder used to this product is melted in reflow process.
Therefore do not add excessive vibration and strong air below to this product during reflow.
Please take out the products from a reflow furnace after the product temperature is cooled down thoroughly.
When this product is mounted on backside of a motherboard like the below figure, the measurement except soldering should be taken with dipping thermal setting resin around NCo pins and a metal core cover to prevent this product from dropping.

⚠ Note:

1. This datasheet is downloaded from the website of Murata Manufacturing co., ltd. Therefore, it's specifications are subject to change or our products in it may be discontinued without advance notice. Please check with our sales representatives or product engineers before ordering.
2. This datasheet has only typical specifications because there is no space for detailed specifications. Therefore, please approve our product specifications or transact the approval sheet for product specifications before ordering.

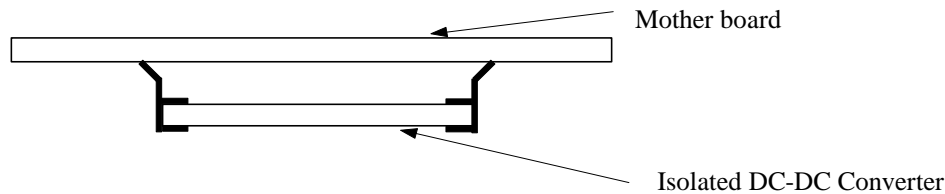

13. 2 Cleaning

13. 2. 1 Please clean this product to remove flux by using dip, boil, and vapor methods in isopropyl alcohol for up to 5 minutes.
Please inform us if you are to use aqueous or semi-aqueous cleaning or other methods.
Do not use ultrasonic cleaning because semiconductor device on this product maybe damaged by resonance.

13. 2. 2 After cleaning, please dry this product thoroughly.
If you touch the wet product, marking maybe erased or blurred.
Do not measure electrical characteristics, until this product gets dried enough.

13. 2. 3 If you don't clean this product with no-cleaning type flux, you must confirm fully in advance the reliability of this product.

13. 3 Storage

13. 3. 1 Please store the products in room where the temperature/humidity is stable and direct sunlight cannot come in, and use the products within 6 months after delivery.
Please avoid damp and heat or such places where the temperature greatly changes, as water may condense on this product, and the quality of characteristics may be reduced, and/or be the solderability may be degraded.
If this product needs to be stored for a long time (more than 1 year), this product may be degraded in solderability and/or corroded. Please test the solderability of this product regularly.
Baking before reflow process is unnecessary to store the products under 30°C,60%RH or less up to 6 months.
If the storage condition is over above mentioned, recommend a baking at 100±5°C,24 hours before reflow process.

13. 3. 2 Please do not store this product in the conditions such as a dusty place, a place exposed directly to sea breeze, or in an atmosphere containing corrosive gas (Cl₂, NH₃, SO₂, NO_X and so on).

13. 4 Operational Environment and Operational Conditions

13. 4. 1 Operational Environment

This product is not water-, chemical- or corrosion-proof.

In order to prevent leakage of electricity and abnormal temperature rise of this product, do not use this product in the following conditions:

- (1) in an atmosphere containing corrosive gas (Cl₂, NH₃, SO₂, NO_X and so on)
- (2) in a dusty place
- (3) in a place exposed to direct sunlight
- (4) in such a place where water splashes or in such a humid place where water condenses
- (5) in a place exposed to sea breeze
- (6) in any other places similar to the above

13. 4. 2 Operational Conditions

Please use this product within specified values (power supply, temperature, input, output, load condition, and so on).

If not used within the specified values, defectiveness and deterioration of this product may be caused. Even if this product can endure the condition for short time, it may cause degradation of reliability.

It is recommended that a fuse is inserted in input line (V_{in}) to secure safety in any abnormality such as internal circuit of Isolated DC-DC Converter broken down.

Also please take care that the external voltage over output voltage of DC-DC Converter does not applies to output of this Isolated DC-DC Converter.

⚠ Note:

1. This datasheet is downloaded from the website of Murata Manufacturing co., Ltd. Therefore, it's specifications are subject to change or our products in it may be discontinued without advance notice. Please check with our sales representatives or product engineers before ordering.
2. This datasheet has only typical specifications because there is no space for detailed specifications. Therefore, please approve our product specifications or transact the approval sheet for product specifications before ordering.

13. 4. 3 Note prior to use

Defectiveness and reliability degradation may be caused if high static electricity, over rated voltage or reverse voltage are applied to this product. Please be sure to avoid the followings:

- (1) over rating power supply, reverse power supply or inadequate connection of 0 V(DC)line
- (2) electrostatic discharge from production line and/or operator
- (3) electrified product from electrostatic induction

Please avoid an excessive mechanical shock.

If this product is dropped on the floor, etc., a crack to the core of inductors and monolithic ceramic capacitors may occur.

Please handle with care to avoid a strong shock to this product.

Do not give excessive mechanical stress to the product with your handling.

Please control to bend in a maximum of 0.2mm in your application.

13. 5 Transportation

When transporting this product, please pack it in order to avoid damage by mechanical vibration or mechanical shock, and please give instructions and set guidelines to the carriers to prevent rough handling. When transporting this product overseas (in particular, by sea), bad environment of transportation may be expected, therefore please pack this product considering mechanical strength, vibration-resistance and humidity-resistance.

The packaging designed for domestic sales may not suitable for overseas transportation.

Please contact us if this product with domestic packing is transported overseas.

⚠ Note:

1. This datasheet is downloaded from the website of Murata Manufacturing co., ltd. Therefore, it's specifications are subject to change or our products in it may be discontinued without advance notice. Please check with our sales representatives or product engineers before ordering.
2. This datasheet has only typical specifications because there is no space for detailed specifications. Therefore, please approve our product specifications or transact the approval sheet for product specifications before ordering.