

DC-DC Converter Specification

MPD7D128S

1. Application

This specification applies to DC-DC Converter for telecommunication / data-communication equipment, MPD7D128S.

For any other application, please contact us before using this product.

2. Customer Reference

Customer Spec. Number
Customer Part Number

3. Murata Part Number

MPD7D128S

4. Appearance, Dimensions

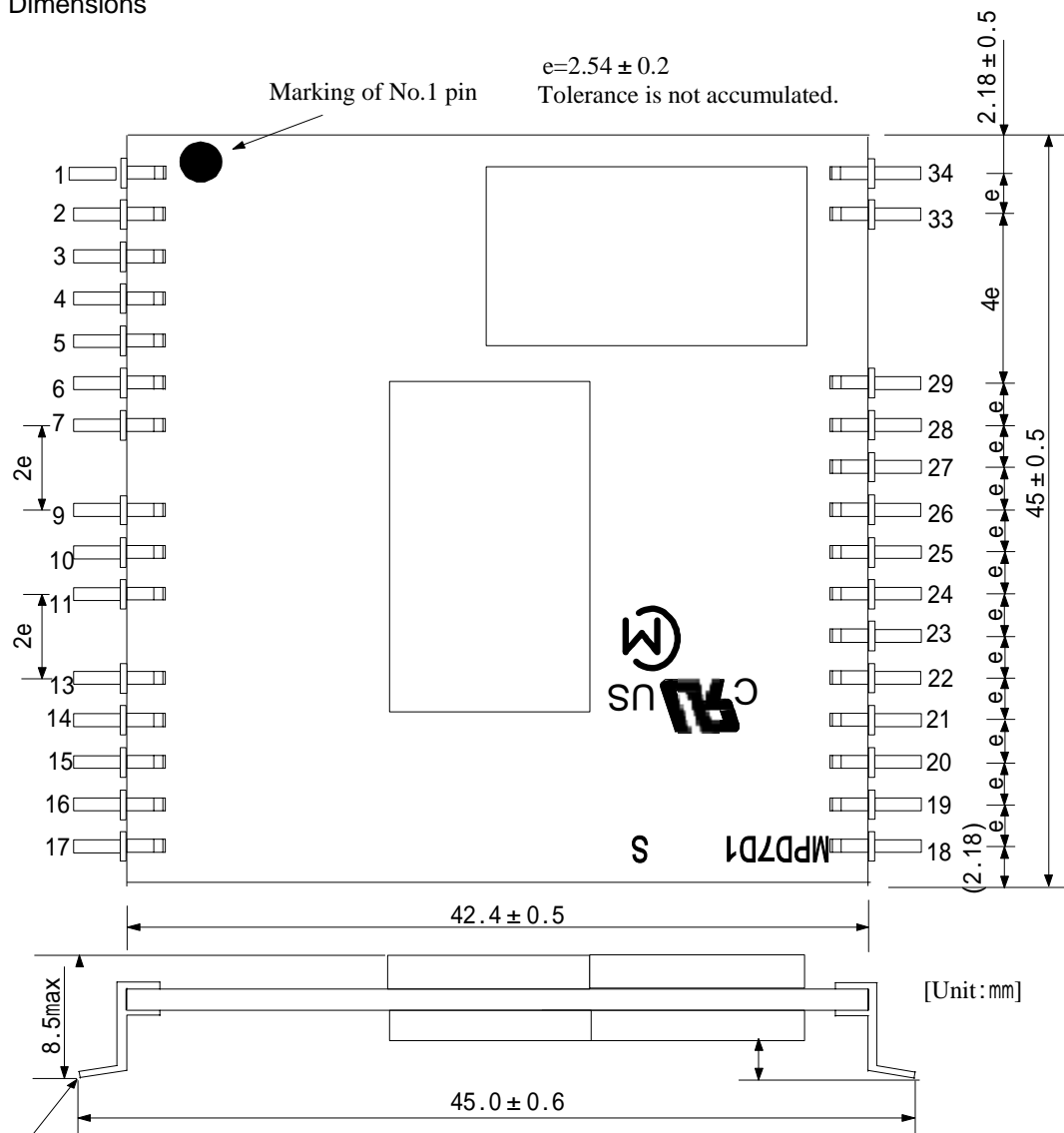

⚠ **Note:** Coplanarity Max0.1

Clearance of product bottom 0.08min

- This datasheet is downloaded from the website of Murata Manufacturing co., ltd. Therefore, it's specifications are subject to change or our products in it may be discontinued without advance notice. Please check with our sales representatives or product engineers before ordering.
- This datasheet has only typical specifications because there is no space for detailed specifications. Therefore, please approve our product specifications or transact the approval sheet for product specifications before ordering.

Marking

- (1) MFG ID 
- (2) Lot No.
 Production factory Mark
 Production Year
 Production Month (1,2,3,...9,O,N,D)
 Product Modification number(No marking now)
- (3) Product Number
 Part number of underlined MPD7D12S

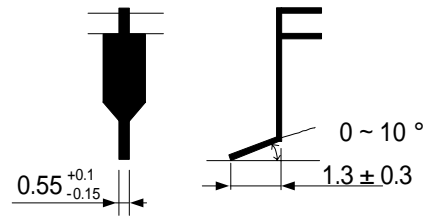

Lead in detail

5 . Pin Number and Function

Pin No.	Symbol	Function
1,2,16,17,18,19,33,34	NC	
3	ALM	Alarm output to stop all in abnormality *1
4,6	NC	
5	RC	Remote ON/OFF
7	PO	Parallel operation. *2
9,10,11	-Vin	(-)Input
13,14,15	+Vin	(+)Input
20,21,22,23	+Vout	(+)Output
24,25,26,27,28,29	-Vout	(-)Output

6. Block Diagram

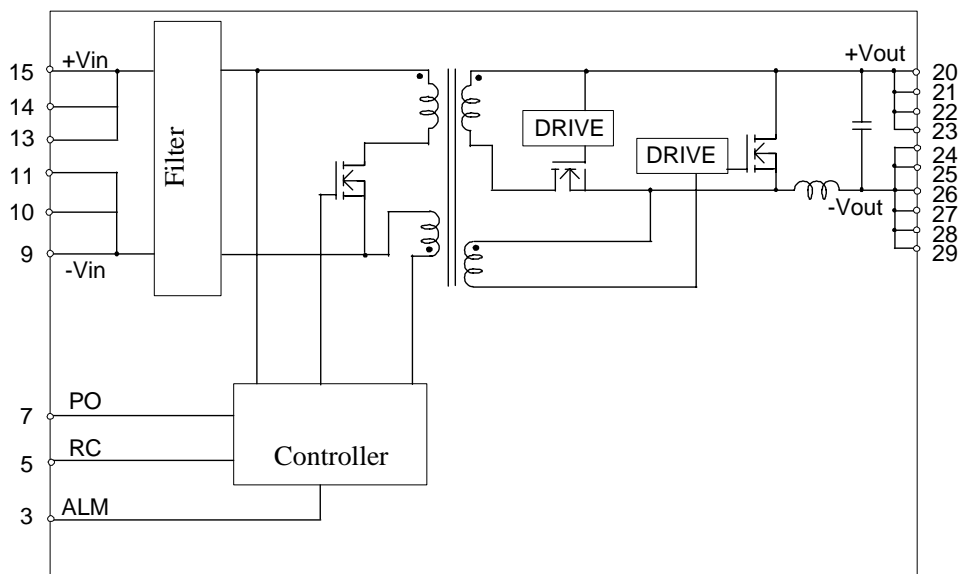

7. Environmental Conditions

- 7.1 Operating Temperature Range -40°C ~ +85°C
- 7.2 Storage Temperature Range -40°C ~ +85°C
- 7.3 Operating Humidity Range 20% ~ 85% (No water condenses in any cases.)
- 7.4 Storage Humidity Range 10% ~ 90% (No water condenses in any cases.)

⚠ Note:

- This datasheet is downloaded from the website of Murata Manufacturing co., ltd. Therefore, it's specifications are subject to change or our products in it may be discontinued without advance notice. Please check with our sales representatives or product engineers before ordering.
- This datasheet has only typical specifications because there is no space for detailed specifications. Therefore, please approve our product specifications or transact the approval sheet for product specifications before ordering.

8. Absolute Maximum Rating

Item			Unit	Absolute Rating	Remarks
Minimum Input Voltage			V	0	
Maximum Input Voltage ALM Applied Voltage RC Applied Voltage	Time	Continuous	V	75	
		200 μ s	V	100	Slew rate 52V/10 μ s
PO Applied Voltage			V	8	
Maximum ALM Sink Current			mA	10	

No voltage, no matter how instantaneous, shall be applied beyond the absolute maximum voltage rating to this product. If you apply any voltage over this limit the product characteristics will deteriorate or the product itself will be destroyed. Even though it may continue operating for a while after the over-voltage event, its life will likely be shortened significantly. Reliability and life of the module may degrade similarly if the maximum operating voltage rating is continuously exceeded. This product is designed to operate within the maximum operating voltage rating specification.

9. Characteristics

9.1. Electrical Characteristics

9.1.1. General Characteristics (Unless otherwise specified, Ta=-40°C ~ +85°C, thermal derated.)

Item	Symbol	Condition	Value			Unit
			Min.	Typ.	Max.	
Input Voltage Range	Vin	Thermal derated	36	48	75	V
Turn-on Input Voltage		Vin = increasing	32	-	36	V
Input Voltage difference of Turn-on and Turn-off		PO pin : Open or Connected to PO pin of other DC-DC Converter	2.0	-	-	V
Galvanic Isolation Voltage		Input time : 1 minute	1500	-	-	Vdc

Item	Standard	Note
Noise(Radiation, Conduction)	In accordance with VCCI Class A	Refer to Test Circuit in clause 10
Safety Standard	Recognized UL60950(UL/C-UL), Complied IEC60950	UL file No. E190503
	CE Marking	CE Mark is shown on a package box.

9.1.2. Specific Characteristics (Ta=-40°C ~ +85°C, thermal derated)

Part Number		MPD7D128S				
Item	Symbol	Condition	Value			Unit
			Min.	Typ.	Max.	
Nominal Output Voltage	Vout		-	5.0	-	V
Output Current	Iout	Thermal derated	0	-	20	A
Output Voltage Tolerance	Vo tol	Vin=36~75V, Io=0~15A Ta=-40~+85°C	-3	-	+5	%
Ripple Voltage	Vrpl	Refer to Test Circuit	-	-	50	mV(pp)
Ripple noise Voltage	Vnoise		-	-	125	
Efficiency	EFF	at rated Vin, Io, Ta=25°C	-	92.5	-	%
Over Current Protection	OCP		21	-	-	A
Over Voltage Protection	OVP	Vin=36 to 75V, Load=50 to 100% Output halts in latch-up mode after mask time 0.5msec (typ) to avoid malfunction by noise and transient change. Input turn off and on to reset.	6.0	-	-	V
Low Voltage Protection	LVP	Output halts in latch-up mode after mask time 500msec (typ) to avoid malfunction by noise and transient change. Input turn off and on to reset.	-	-	4.5	V

⚠ Caution

The above electrical characteristics are guaranteed with the condition that the impedance of the input voltage source is sufficiently low as shown in section 10. Connecting an input inductance or using an input power supply with output inductance may cause an unstable operation of this device. Please check the proper operation of this device with the peripheral circuits on your system.

⚠ Note:

- This datasheet is downloaded from the website of Murata Manufacturing co., Ltd. Therefore, its specifications are subject to change or our products in it may be discontinued without advance notice. Please check with our sales representatives or product engineers before ordering.
- This datasheet has only typical specifications because there is no space for detailed specifications. Therefore, please approve our product specifications or transact the approval sheet for product specifications before ordering.

9.1.3. Thermal Derating <Reference>

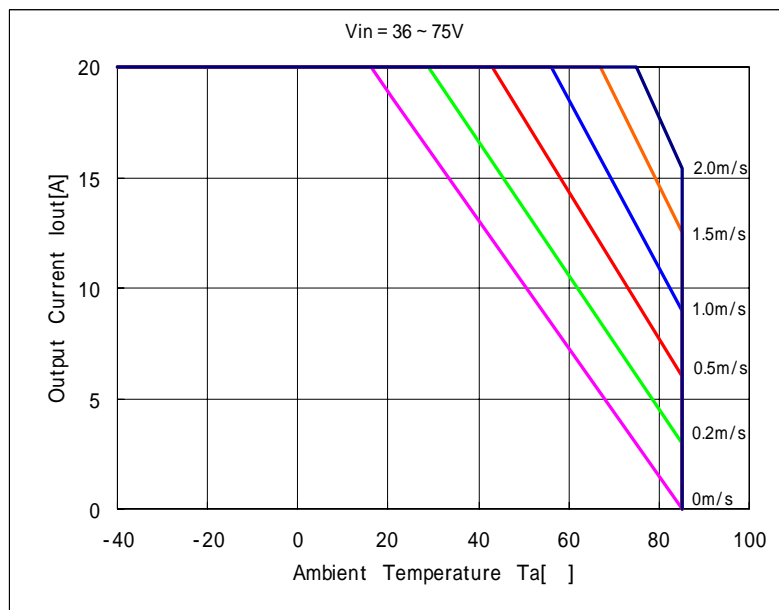
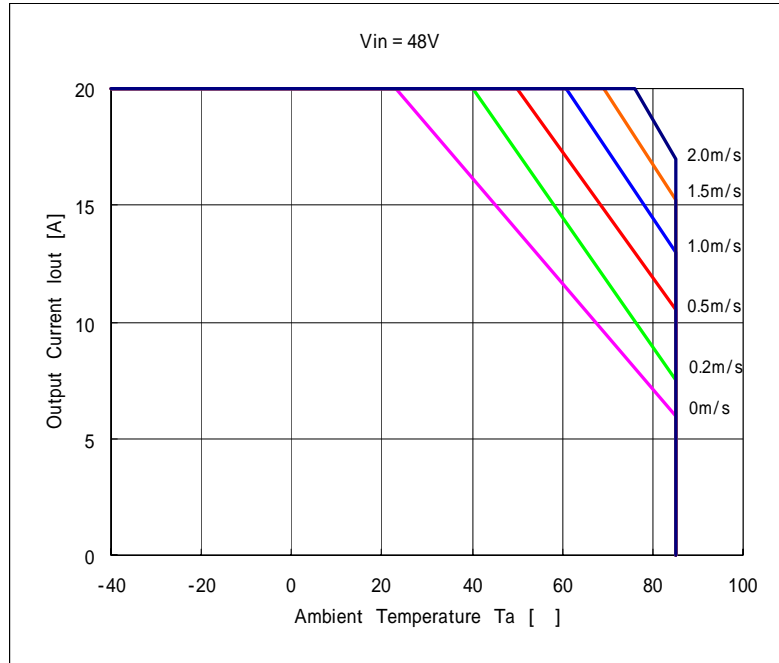

The above derating limits apply to this product soldered directly to 101.6*101.6mm 6layer PCB. Any adjacent parts of high temperature may cause overheating.

[Note]

We would like to emphasize the data is based on our experimental measurement.
Please measure ambient temperature around a DC-DC Converter on your applications.

⚠ Note:

1. This datasheet is downloaded from the website of Murata Manufacturing co., ltd. Therefore, it's specifications are subject to change or our products in it may be discontinued without advance notice. Please check with our sales representatives or product engineers before ordering.
2. This datasheet has only typical specifications because there is no space for detailed specifications. Therefore, please approve our product specifications or transact the approval sheet for product specifications before ordering.

9.2. Operation Information

9.2.1. Reset Condition

In order to reset all function, the input Voltage is set under 5V for Min.1 second.

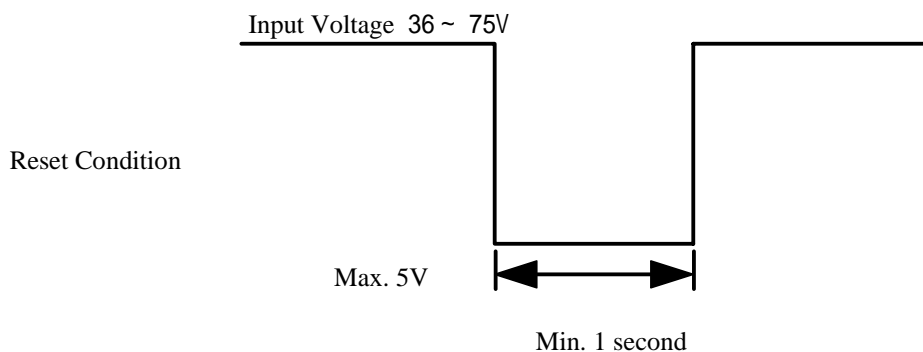

9.2.2. Over Voltage Protection

Output halts in latch-up mode after 0.5msec(typ) mask time while Output Voltage is over the value of over voltage protection specified in 9.1. clause with failure of controller circuit.

Output will re-start after input turns off for Min. 1 second with input voltage less than 5V.

Output voltage might exceed the point at over voltage protection under the specific condition of transient change of input voltage or output load, in this condition over voltage protection wait its start until the mask time.

It is recommended to evaluate your appliance installed with DC-DC converter.

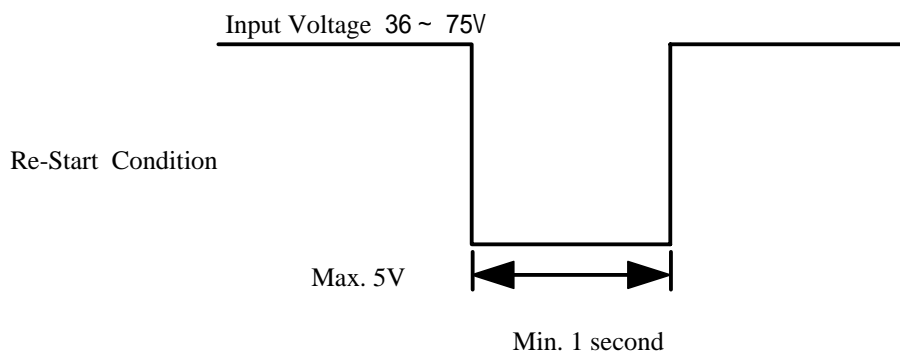

9.2.3. Low Voltage Protection

Output halts in latch-up mode after 500msec(typ) mask time while output voltage is below the value of low voltage protection specified in 9.1.clause with failure of controller circuit or over load condition.

Output will re-start after input turns off for Min.1 second with input voltage less than 5V.

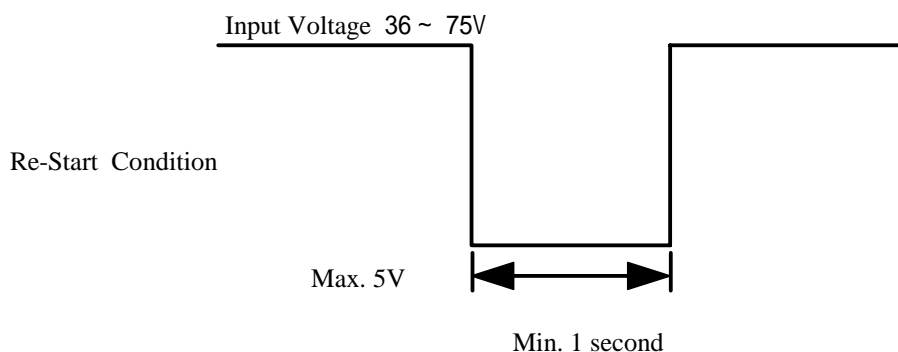

⚠ Note:

1. This datasheet is downloaded from the website of Murata Manufacturing co., ltd. Therefore, it's specifications are subject to change or our products in it may be discontinued without advance notice. Please check with our sales representatives or product engineers before ordering.
2. This datasheet has only typical specifications because there is no space for detailed specifications. Therefore, please approve our product specifications or transact the approval sheet for product specifications before ordering.

9.2.4. Remote ON/OFF Control

Start and halt is possible with a control signal.

While the control signal stops output from DC-DC converter, alarm output does not send any signal.

Start : RC is open or connected to-Vin.

Halt : RC is connected to +Vin.

9.2.5. Alarm Output

ALM pin is down to the same voltage level of-Vin pin and sends an alarm signal. (open-drain output)

Sink current in ALM pin is Max.10mA.

It is possible to halt all of the connected DC-DC converters when any one is halted with over voltage protection or low voltage protection, with connecting all ALM pins for the application of parallel/multiple operation with plural DC-DC converters.

The maximum number connecting DC-DC converters is 10pcs for the purpose of halting all DC-DC converters connected with ALM pin each other.

Please contact us when more than 10pcs..

9.2.6. Synchronous Turn-on/off

It is possible to avoid the unevenness of turn-on timing with unifying the various Turn-on input voltage to a certain voltage which one DC-DC converter has, and with connecting PO pins each other for the application of parallel/multiple operation of plural DC-DC converters.

It is necessary to connect PO pins for parallel operation.

The maximum number connecting DC-DC converters is 10pcs for the purpose of synchronous turn-on/off with connecting PO pins.

Please contact us when more than 10pcs.

9.3. Reliability

9.3.1. Humidity

According to JIS-C-0022.

40 ± 2°C, 90 to 95%RH, 100 hours. Leave for 4 hours at room temperature.

No damage in appearance and no deviation from electrical characteristics (section 9.1.).

9.3.2. Temperature Cycles

Repeat cycle 5 times. Leave 2 hours at room temp.

No damage in appearance and no deviation from electrical characteristics (section 9.1.)..

Step	Condition	Time
1	-40°C ± 3°C	30 minutes
2	Room Temp.	5-10 minutes
3	+85°C ± 2°C	30 minutes
4	Room Temp.	5-10 minutes

9.3.3. Vibration

10 to 55Hz, 1.5mm amplitude (1minute cycle), 1 hour for each of X, Y, Z directions.

No damage in appearance and no deviation from electrical characteristics (section 9.1.).

9.3.4. Mechanical Shock

20G, 1 time for each X, Y, Z directions.

No damage in appearance and no deviation from electrical characteristics (section 9.1.).

⚠ Note:

1. This datasheet is downloaded from the website of Murata Manufacturing co., ltd. Therefore, it's specifications are subject to change or our products in it may be discontinued without advance notice. Please check with our sales representatives or product engineers before ordering.
2. This datasheet has only typical specifications because there is no space for detailed specifications. Therefore, please approve our product specifications or transact the approval sheet for product specifications before ordering.

10. Test Circuit

In the following test circuit, the initial values under item 9.1. should be met.

10.1. General Measure Circuit

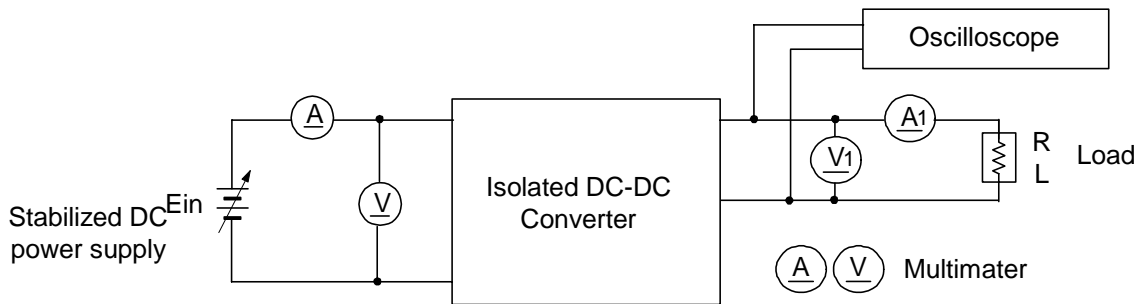

10.2. Ripple Noise Measurement Circuit

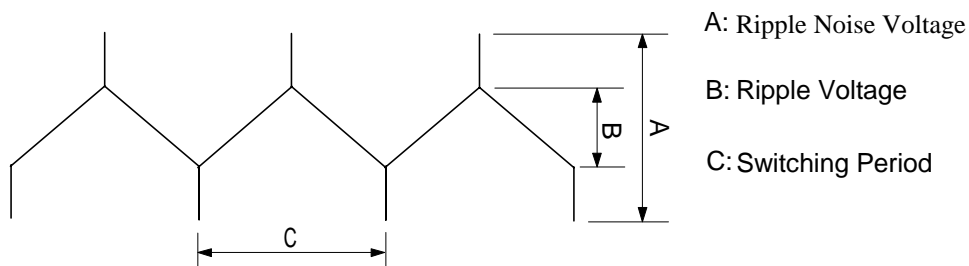
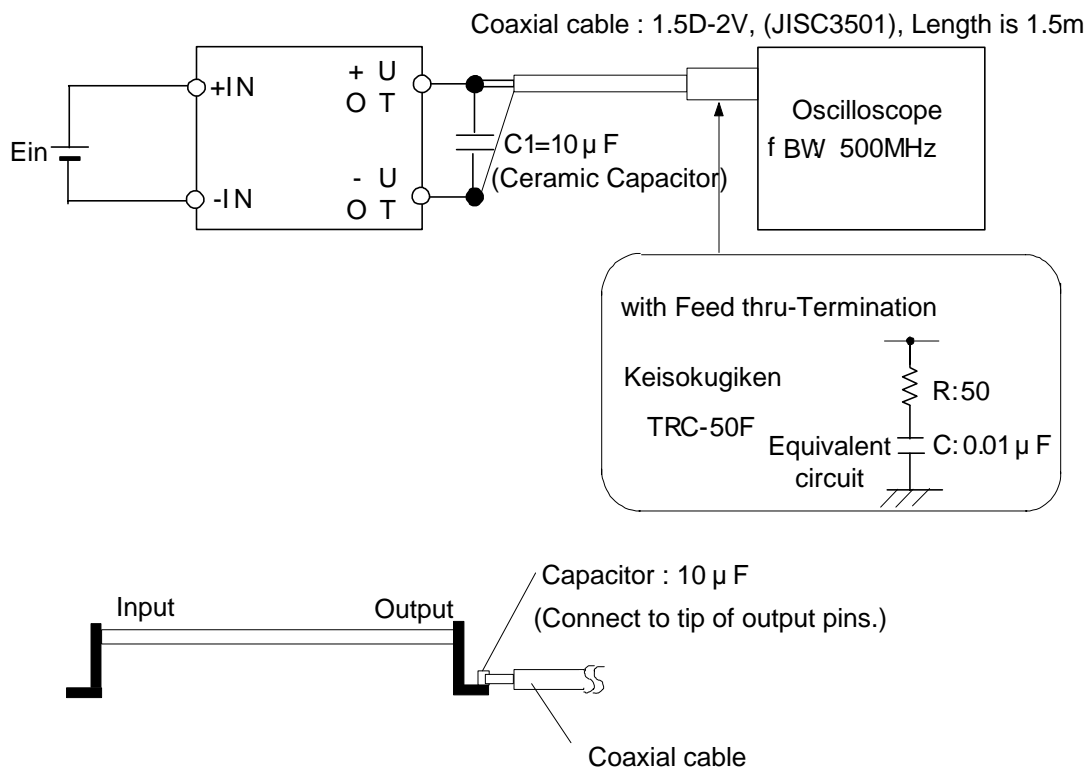

⚠ Note:

1. This datasheet is downloaded from the website of Murata Manufacturing co., ltd. Therefore, it's specifications are subject to change or our products in it may be discontinued without advance notice. Please check with our sales representatives or product engineers before ordering.
2. This datasheet has only typical specifications because there is no space for detailed specifications. Therefore, please approve our product specifications or transact the approval sheet for product specifications before ordering.

10.3. Radiation Noise Measurement Circuit

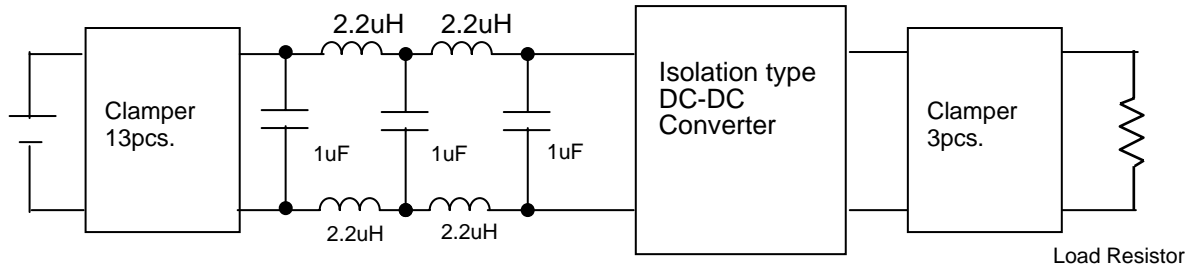

Clamper : ZCAT3035-1330(TDK)

10.4. Conduction Noise Measurement Circuit

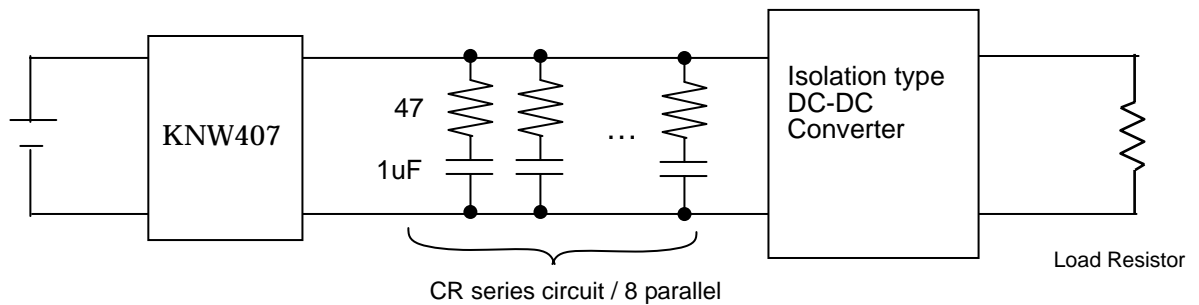

Measurement at Radiation Noise, Conduction Noise, Output ripple & Noise.

Please measure Radiation Noise, Conduction Noise and Output ripple & Noise with conforming to the Test Circuit in clause 10..

Otherwise the noise might not meet the specified values.

⚠ **Note:**

1. This datasheet is downloaded from the website of Murata Manufacturing co., ltd. Therefore, it's specifications are subject to change or our products in it may be discontinued without advance notice. Please check with our sales representatives or product engineers before ordering.
2. This datasheet has only typical specifications because there is no space for detailed specifications. Therefore, please approve our product specifications or transact the approval sheet for product specifications before ordering.

11. Packaging Specification
 11.1. Tray Dimensions

DC-DC converters are put in the trays. (See Fig.1)

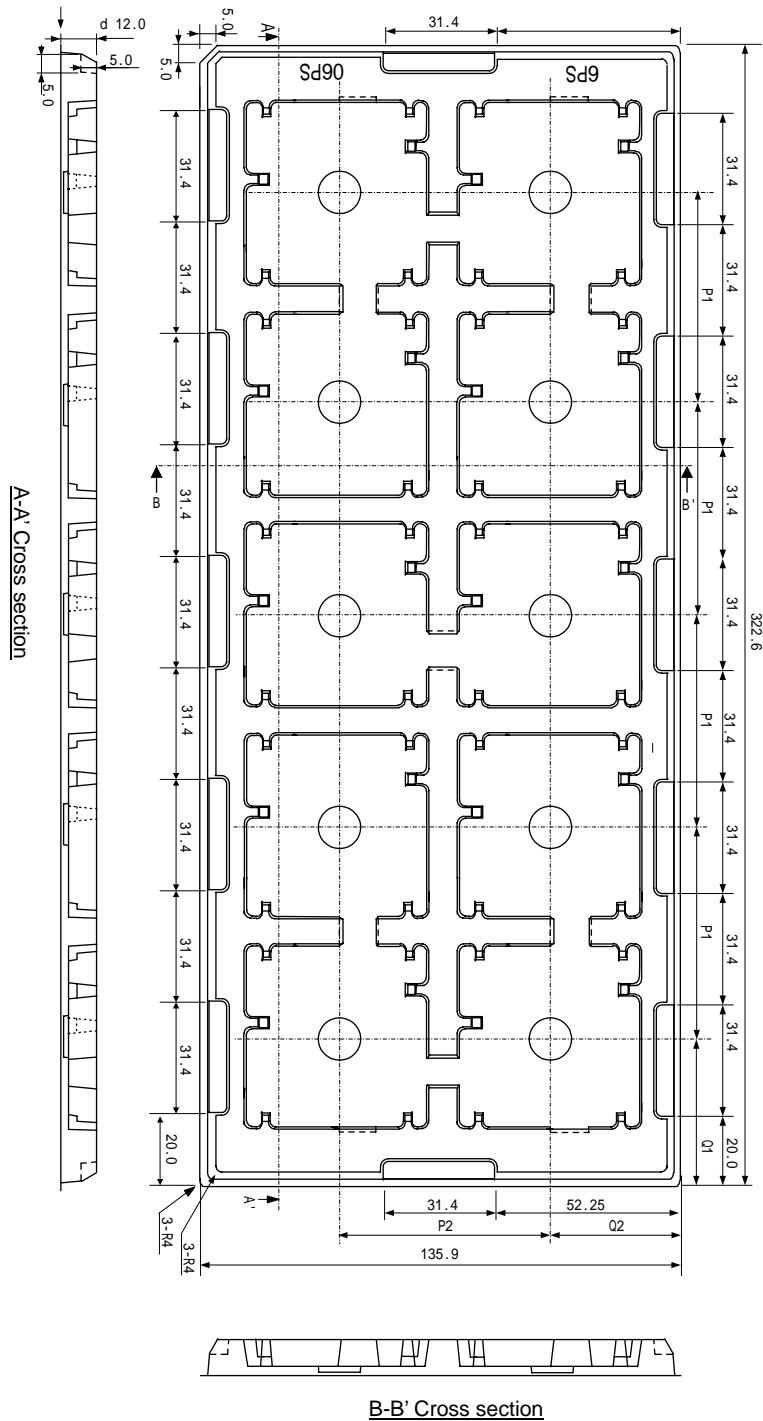

Q1=43.3
 Q2=39.7
 P1=59.0
 P2=56.5

Fig. 1

Note:

1. This datasheet is downloaded from the website of Murata Manufacturing co., ltd. Therefore, it's specifications are subject to change or our products in it may be discontinued without advance notice. Please check with our sales representatives or product engineers before ordering.
2. This datasheet has only typical specifications because there is no space for detailed specifications. Therefore, please approve our product specifications or transact the approval sheet for product specifications before ordering.

11.2. The direction of products in the cavity

Fig.2 shows the direction of products in the cavity.

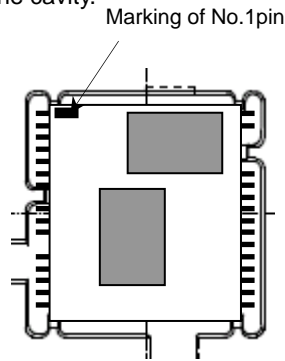

Fig.2

11.3. Contained pieces of products per corrugated box.

Maximum contained products pieces 40 pcs./corrugated box.

Further plural sheets of corrugated cardboard are placed on the top of the dummy tray according to number of contained trays in order to full up the space in a corrugated box.

11.4. Packing Form

Trays with products are lidded and packed in a corrugated box. (See Fig.3)

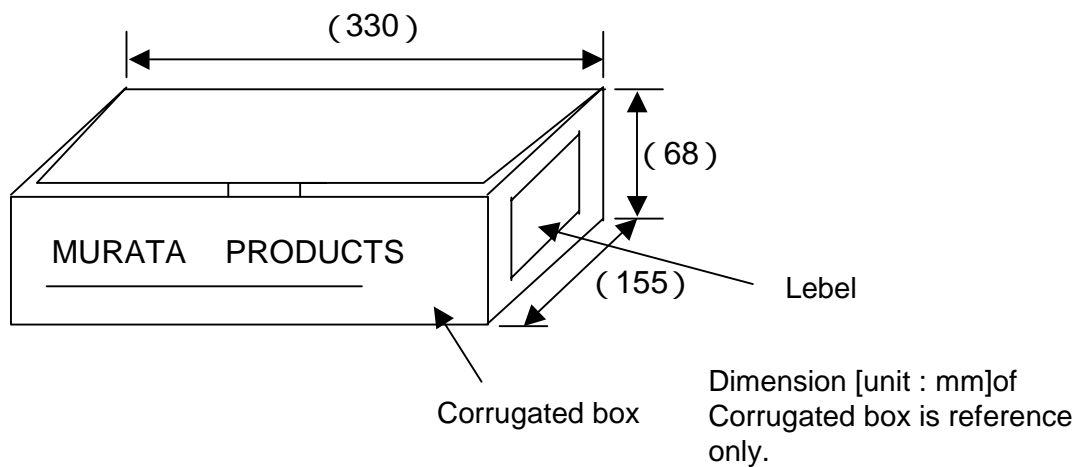
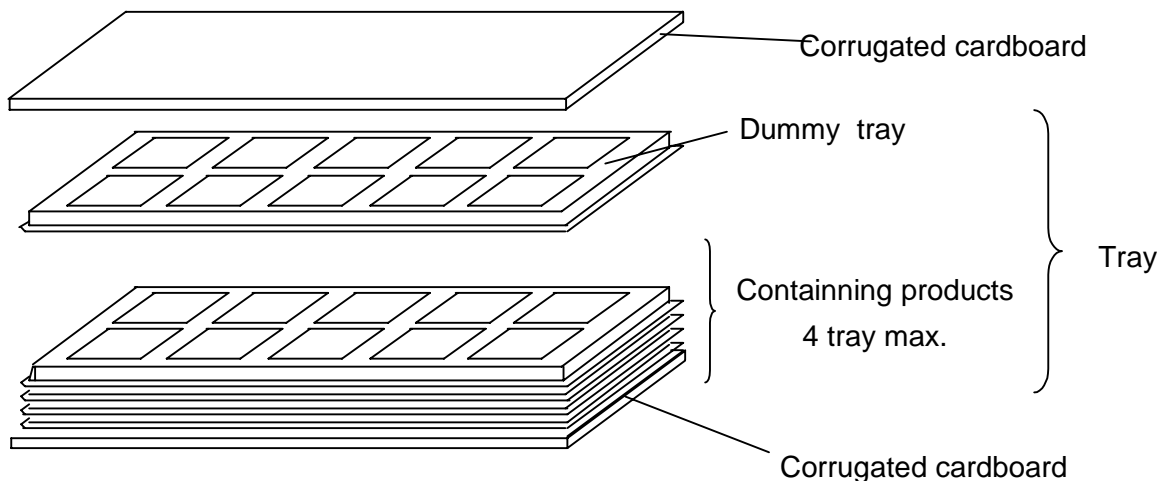

Fig.3

⚠ Note:

1. This datasheet is downloaded from the website of Murata Manufacturing co., ltd. Therefore, it's specifications are subject to change or our products in it may be discontinued without advance notice. Please check with our sales representatives or product engineers before ordering.
2. This datasheet has only typical specifications because there is no space for detailed specifications. Therefore, please approve our product specifications or transact the approval sheet for product specifications before ordering.

Marking on the box.

1. Murata Parts Number 2. Quantity 3. Inspection No. 4. CE Mark 5. RoHS-Y<*>

[RoHS-Y<*>] is shown on a package label of RoHS compliant products. <*> is revision code of RoHS Directive like A>B>C...

The regulation shown with alphabet of * refers to an other attached document [Indication Express for Regulation about Hazardous Substance of Use Limitation]

12. Production factory

Komatsu Murata Mfg.Co., Ltd.

Kanazu Murata Mfg. Co., Ltd.

Wakura Murata Mfg. Co., Ltd.

13. Caution

1. Be sure to provide an appropriate fail-safe function on your product to prevent secondary damage that may be caused due to abnormal functional or failure of this product.
2. Inrush current protection is not a feature of this product.
3. Please connect the input terminals with the correct polarity. If an error in polarity connection is made this product may be damaged. If this product is damaged internally, an elevated input current may flow, and so this product may exhibit an abnormal temperature rise, or your product may be damaged. Please add a diode and fuse per the following diagram to protect them.

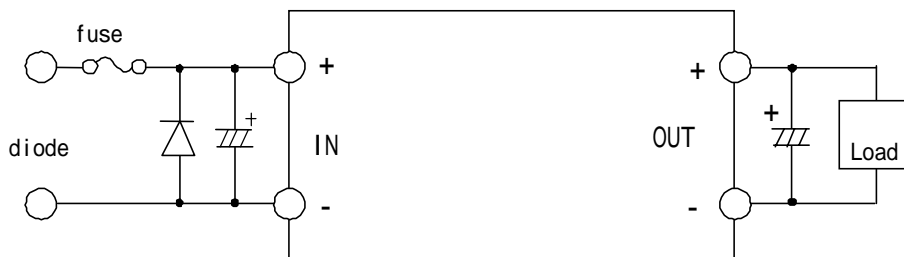

Please select diode and fuse after confirming the operation of your product.

4. Limitation of Application

Please contact us before using this product for the applications listed below which require especially high reliability for the prevention of defects, which might directly cause damage to the third party's life, body or property.

Aircraft equipment
 Aerospace equipment
 Undersea equipment
 Power plant control equipment
 Medical equipment
 Transportation equipment (vehicles, trains, ships, etc.)
 Traffic signal equipment
 Disaster prevention /crime prevention equipment
 Any other application of similar complexity and/or reliability requirements to the applications listed above.

Note:

1. This datasheet is downloaded from the website of Murata Manufacturing co., ltd. Therefore, it's specifications are subject to change or our products in it may be discontinued without advance notice. Please check with our sales representatives or product engineers before ordering.
2. This datasheet has only typical specifications because there is no space for detailed specifications. Therefore, please approve our product specifications or transact the approval sheet for product specifications before ordering.

14. Notice

14.1. Soldering

14.1.1. Flux

Please solder this product with Rosin Flux that contains of 0.2wt% or less chlorine.
Please do not use high activity acid flux or water-soluble flux as they may reduce the reliability of this product.

14.1.2. Soldering Conditions Recommendation

Reflow Soldering

This product is RoHS compliant. The following profile is recommended for the reflow of this product using Pb-free solder paste (Sn-Ag-Cu).

Method : Full convection reflow soldering

Reflow Soldering Profile

JEDEC IPC/JEDEC J-STD-020D

Table 5-2 Classification Reflow Profile

Pb-Free Assembly Large Body

Profile details

Soldering temperature : 245°C+0/-5°C
Soldering time : 30 seconds, 240 to 245°C
Heating time : 60 to 150 seconds, over 217°C
Preheating time : 60 to 120 seconds, 150 to 200°C
Programming rate : 3°C/ sec. Max., 217 to 245°C
Descending rate : 6°C/ sec. Max.
Total soldering time : 8 minutes Max., 25 to 245°C
Times : 1 time

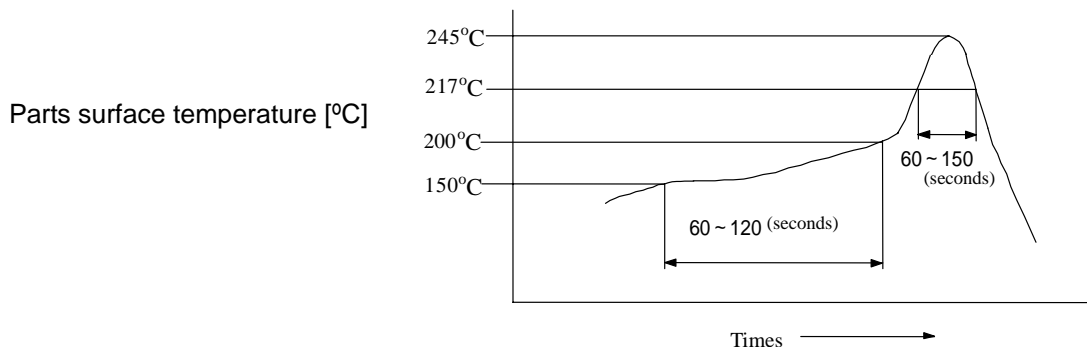

Do not vibrate for the products on reflow.

Please need to take care temperature control because mounted parts may come off if the product are left under the high temperature.

Do not reflow DC-DC converter as follows, because DC-DC converter may fall down from a substrate during reflowing.

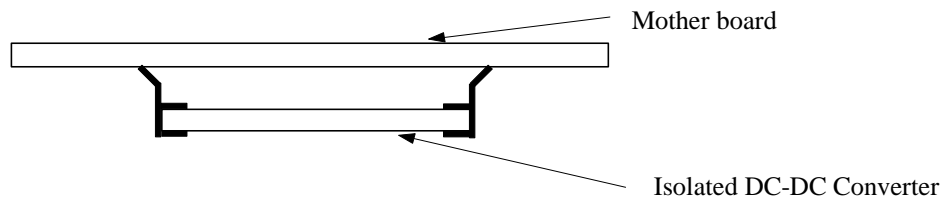

⚠ Note:

1. This datasheet is downloaded from the website of Murata Manufacturing co., ltd. Therefore, it's specifications are subject to change or our products in it may be discontinued without advance notice. Please check with our sales representatives or product engineers before ordering.
2. This datasheet has only typical specifications because there is no space for detailed specifications. Therefore, please approve our product specifications or transact the approval sheet for product specifications before ordering.

14. 2. Cleaning

Please use no-cleaning type flux and do not wash this product.

14.3. Storage

14.3.1. Please store the products in room where the temperature/humidity is stable and direct sunlight cannot come in, and use the products within 6 months after delivery.

Please avoid damp and heat or such places where the temperature greatly changes, as water may condense on this product, and the quality of characteristics may be reduced, and/or be the solderability may be degraded.

If this product needs to be stored for a long time (more than 1 year), this product may be degraded in solderability and/or corroded. Please test the solderability of this product regularly.

Baking before reflow process is unnecessary to store the products under 30 ± 5 °C, 60%RH or less up to 6 months.

In case the storage condition is over above mentioned, if these are unpacked condition, please bake them at 125 ± 5 °C /24hour. If these are packed in a tape, please bake them before soldering at 60 ± 5 °C /168hour.

14.3.2. Please do not store this product in places such as :

A dusty place, a place exposed directly to sea breeze, or in an atmosphere containing corrosive gas (Cl₂,NH₃,SO₂,NO_x and so on).

14. 4. Operational Environment and Operational Conditions

14.4.1. Operational Environment

This product is not water-, chemical- or corrosion-proof.

In order to prevent leakage of electricity and abnormal temperature rise of the product,do not operate under the following environmental conditions:

- (1) An atmosphere containing corrosive gas (Cl₂, NH₃, SO₂, NO_x and so on)
- (2) A high-dust environment
- (3) Under the exposure of direct sunlight
- (4) A location where the likelihood of exposure to water or water condensation exists.
- (5) A location exposed to ocean air
- (6) Any locations similar to the above

14.4.2. Operational Conditions

Please use this product within specified values (power supply, temperature, input, output and load condition, and so on). If the product is exposed to conditions outside of the specified values reliability of the product may be adversely effected.

14.4.3. Note prior to use

Diminished reliability and/ or failure may result if the product is exposed to a high-level static charge, over-rated voltage or reverse voltage. Please avoid the following conditions be avoided prior to use of the product:

- (1) Supply of power outside of rated values (see section 8)
- (2) Supply of reverse power or inadequate connection of a 0 V(DC)line
- (3) Electrostatic discharge from production line and/ or operator
- (4) Electrification of the product from electrostatic induction
- (5) Excessive mechanical shock

14.5. Transportation

Murata recommends that when transporting this product, it be packed so as to avoid damage by mechanical vibration or exposure to adverse conditions such as ocean air, high humidity. It is additionally recommended that appropriate instructions and guidelines be communicated to carriers to prevent exposure to these same conditions.

15. Note

1. Murata recommends that customers ensure that the evaluation and testing of these devices are completed with this product actually assembled on their product.
2. All the items and parameters in this product specification have been prescribed on the premise that Murata's product is used for the purpose, under the condition and in the environment mutually agreed upon.

**This document is for reference only and subject to revision without prior of subsequent notice.
Please contact Murata for latest documentation.**

Note:

1. This datasheet is downloaded from the website of Murata Manufacturing co., ltd. Therefore, it's specifications are subject to change or our products in it may be discontinued without advance notice. Please check with our sales representatives or product engineers before ordering.
2. This datasheet has only typical specifications because there is no space for detailed specifications. Therefore, please approve our product specifications or transact the approval sheet for product specifications before ordering.