

**OBSOLETE PRODUCT**



This product is not RoHS compliant.

**Features**

- 0-10V input/control voltage
- 0-20A output/load current
- 0.6-50V output compliance voltage
- 0-100W output/load power
- 10MΩ output impedance
- 500Vdc isolation
- ±2% accuracy under all conditions
- 200μsec full-scale step response
- 2" x 2", shielded metal package
- Operate in parallel for higher power

**Applications**

- Power-supply test and characterization
- Static/dynamic power-supply burn-in
- Power-resistor substitution
- Real-time load simulation
- Capacitor discharge testing

The DTL22A-LC is an isolated (500Vdc), near-ideal ( $Z_{IN} = Z_{OUT} \geq 10M\Omega$ ), analog/voltage-controlled current sink. Its 0-20A output/load current is straightforwardly "programmed" by applying a 0-10V input. The control signal can be generated by circuits as simple as the wiper of a trimpot or as sophisticated as programmable logic controllers (PLC's) or analog-output computer I/O boards (D/A boards). The DTL22A-LC supports any combination of  $I_{OUT} = 0-20$  Amps and  $V_{OUT} = 2.5-50$  Volts. Its thermally efficient, metal package, when properly heat sunk, can dissipate output/load power up to 100 Watts.

The easy-to-use DTL22A-LC is an excellent building block for low-cost, fully flexible, power-supply (AC/DC or DC/DC) or power-component (MOSFET's, diodes, etc.) test and burn-in applications. It is accurate ( $\pm 5mA$  offset error,  $\pm 1\%$  overall accuracy), fast (200μsec full-scale step response), and capable of impressive resolution. If it is controlled with a 12-bit, 0-10V D/A converter, for example, one LSB (least significant bit) of the D/A corresponds to a 5mA change in the DTL22A-LC's output/load current.

The DTL22A-LC is packaged in a small (2" x 2" x 0.5"), thermally efficient metal package incorporating an aluminum baseplate with threaded inserts. It is powered by a single +5V supply and draws a mere 150mA.

The DTL22A-LC has an output compliance voltage of 0.6-50 Volts. Should the output/load voltage drop below the 0.6V required for proper biasing, an internal monitoring circuit activates the DTL22A-LC's output Fault line.

The DTL22A-LC and other electronic loads, controller boards, and software from DATEL are outstanding building-block components for power-supply burn-in and test systems. They are extremely reliable, cost-effective solutions that enable you to quickly configure impressively accurate systems.

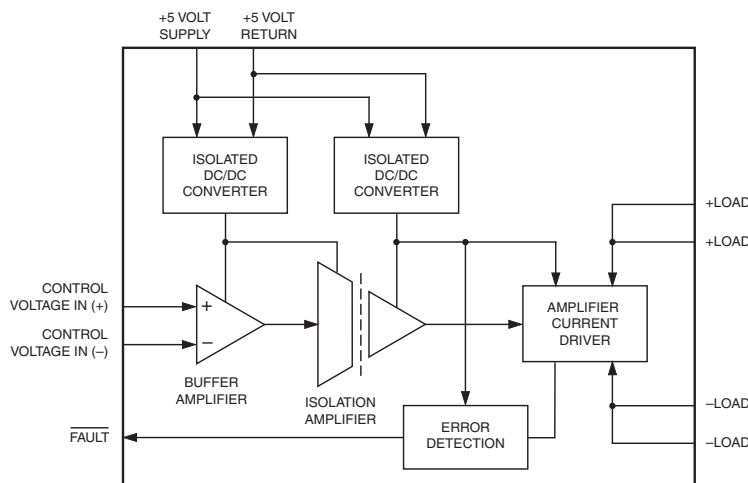

Figure 1. Simplified Schematic

①

**Performance Specifications and Ordering Guide**

Model	Input		Output				Package (Case, Pinout)
	Control Voltage (Volts)	Impedance (Minimum)	Current (Amps)	Resolution (mA) ②	Compliance Voltage (Volts) ③	Power (Watts)	
DTL22A-LC	0 to +10	10MΩ	0-20	5	0.6-50	0-100	C24, P51

- ① Typical at TA = +25°C with nominal +5V supply voltage, unless noted.
- ② Listed resolution (5mA) is for a typical application in which the DTL22A-LC is controlled by a voltage generated by a 12-bit D/A converter with a 0-10V output range. One LSB (least significant bit) of the D/A corresponds to 0.0244% (1/4096) of full scale (20 Amps), which equals approximately 5mA.
- ③ For proper operation, the unit's output/load voltage must remain within this range. Voltages greater than the listed maximum can damage the device. Voltages less than the minimum provide insufficient bias for the output stage and will result in unpredictable or no operation. See Output Compliance Voltage and the Fault Line for details.

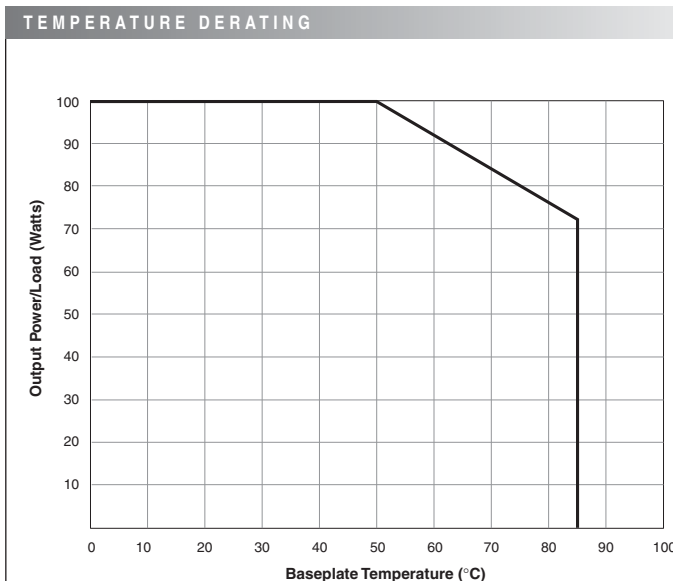
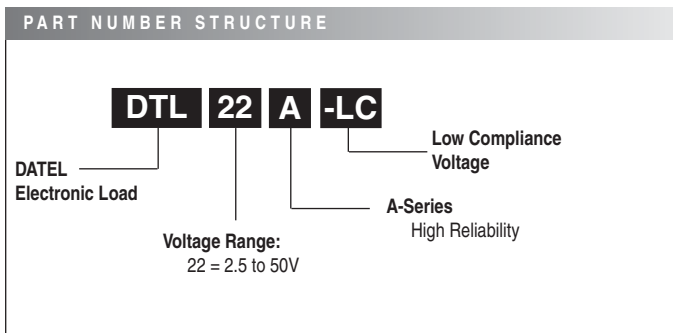

The horizontal axis of the above chart references the temperature of the DTL22A-LC's aluminum baseplate. The device can continually dissipate up to 100 Watts if the baseplate is maintained at or below +50°C. At +25°C ambient temperature, with no heat sink or supplemental air flow, the DTL22A-LC can reliably dissipate a continuous 10 Watts.

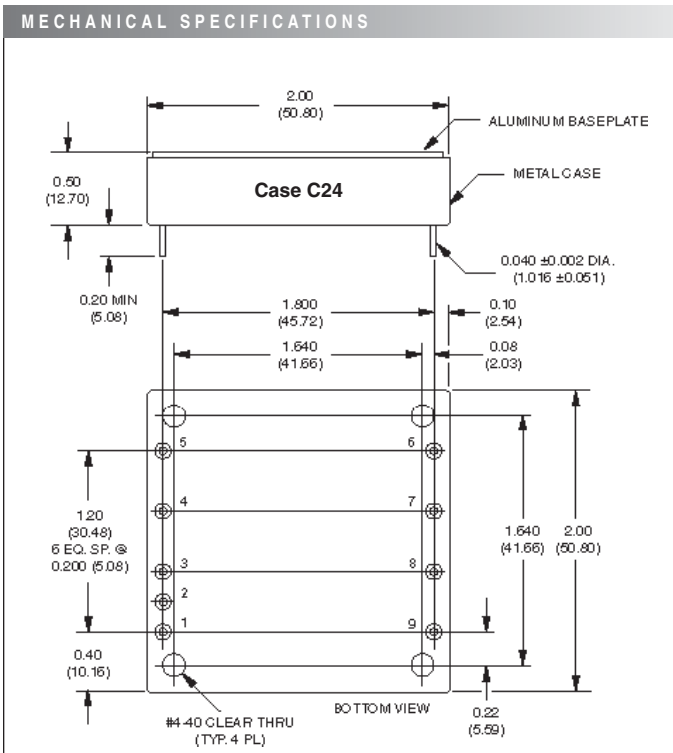

**I/O Connections**

Pin	Function P51	Pin	Function P51
1	+5 Volt Supply	7	Control Voltage In (-)
2	+5 Volt Return	8	-Load
3	Fault	9	-Load
4	No Pin	10	+Load
5	Control Voltage In (+)	11	+Load
6	No Pin		

Contact DATEL for Heat Sink information.

## DTL22A-LC Model Voltage-Controlled 20 Amp, 100 Watt, Low-Compliance Electronic Loads

### Performance/Functional Specifications

Typical @ T<sub>A</sub> = +25°C with nominal +5V supply voltage, unless noted.

Input	
Control Voltage	0-10 Volts
Impedance	10MΩ, minimum
Output	
Transfer Function	I <sub>OUT</sub> (Amps) = 2V <sub>IN</sub> (Volts)
<b>Current:</b>	
Range	0-20 Amps
Resolution ①	0.025%FS (5mA)
Offset Error ②	±5mA
Gain Error	±1%, maximum
Absolute Accuracy ③	±2%, maximum
Voltage ④	0.6-50 Volts
Power ⑤	0-100 Watts
<b>Isolation Voltage:</b>	
Analog Input to ±Load	500Vdc, minimum
+5V Power to Input or ±Load	500Vdc, minimum
Any Pin to Case	500Vdc, minimum
Isolation Resistance	100MΩ, minimum
<b>Fault Logic Levels:</b>	
Logic "1" (@ 150μA)	+3.5 Volts, minimum
Logic "0" (@ 1.6mA)	+0.4 Volts, maximum
Dynamic Performance	
Output Slew Rate	0.4A/μsec, minimum
Output Settling Time ⑥	200μsec
<b>Dynamic Loading: ⑥</b>	
10mA to 20A	5kHz
0 to 20A	1kHz
Power Requirements	
Power Supply Range (+V <sub>CC</sub> , Pin 1)	+4.75-5.25 Volts (+5V nominal)
Power Supply Current	110mA typ., 150mA max.
Environmental	
Operating Temperature ⑦	-25 to +85°C
Storage Temperature	-40 to +85°C
Humidity (Non-condensing)	to 95%
Altitude Above Sea Level	10,000 feet
Physical	
Dimensions	2" x 2" x 0.5" (51 x 51 x 12.7mm)
Shielding	6-sided
Case Material	Tin-plated steel shell with aluminum baseplate
Pin Material	Brass, solder coated
Mounting Holes	Through-hole spacers, #4-40 clearance
Weight	1.9 ounces (54 grams)

- ① Listed resolution (5mA) is for a typical application in which the DTL22A-LC is controlled by a voltage generated by a 12-bit D/A converter with a 0-10V output range. One LSB (least significant bit) of the D/A corresponds to 0.0244% (1/4096) of full scale (20 Amps), which equals approximately 5mA.
- ② Offset error is defined as the current sunk/sourced by the DTL22A-LC's output, under any output-voltage conditions, when the applied control voltage is 0 Volts.
- ③ Applies over all ranges/combinations of specified output current, load voltage, output power, operating temperature and V<sub>CC</sub>.
- ④ For proper operation, the DTL22A-LC's output voltage must remain within the range listed. Voltages greater than the listed maximum can damage the device. Voltages less than the listed minimum provide insufficient bias for the output stage and will result in unpredictable or no operation. See Output Compliance Voltage and the Fault Line for details.
- ⑤ The DTL22A-LC can achieve its maximum output/load power only when its baseplate temperature is properly maintained. See Temperature Derating.
- ⑥ Specified for the full-scale step from 10mA to 20 Amps settling to ±1% (±200mA) of final value. A minimal loading of 10mA is recommended to achieve the fastest dynamic response.
- ⑦ Baseplate temperature. See Note 5 and Temperature Derating.

Absolute Maximum Ratings	
Supply Voltage (+V <sub>CC</sub> , Pin 1)	-0.5 to +5.5 Volts
Input Voltage (Pin 5)	-0.5 to 15 Volts
Output Reverse-Polarity Protection	No protection
Output Overvoltage Protection	No protection
Output Undervoltage Protection	Yes (See Fault Line)
Case Temperature	+85°C
Storage Temperature (Ambient)	-40 to +85°C
Lead Temperature (Soldering, 10 sec.)	+300°C

These are stress ratings. Exposure of devices to any of these conditions may adversely affect long-term reliability. Proper operation under conditions other than those listed in the Performance/Functional Specifications Table is not implied.

### TECHNICAL NOTES

#### Overview

The DTL22A-LC is an analog programmable (0 to +10V control) current sink. Its output/load current range is 0 to 20 Amps over a compliance voltage range of 2.5 to 50 Volts and an output/load power range of 0 to 100 Watts.

The device's transfer function is as follows:

$$I_{OUT} \text{ (Amps)} = 2V_{IN} \text{ (Volts)}$$

Examples: Control V<sub>IN</sub> = 1 Volt, I<sub>OUT</sub> = 2 Amps

Control V<sub>IN</sub> = 10 Volts, I<sub>OUT</sub> = 20 Amps

In a typical power-supply test or burn-in application, the "positive" output and "return" pins of the device under test (DUT) are connected to the DTL22A-LC's +Load (pins 10 and 11) and -Load (pins 8 and 9) outputs.

**DTL22A-LC Model Voltage-Controlled  
20 Amp, 100 Watt, Low-Compliance Electronic Loads**

**TECHNICAL NOTES**

**Output Compliance Voltage and the Fault Line**

For proper operation, the DTL22A-LC's output/load voltage must always be between 0.6 and 50 Volts. The device cannot be used to directly load extremely low-voltage (such as 0.5V) power components or to simulate a true short circuit (0 Volts). Voltages greater than 50V can damage the device. Voltages <0.6V will result in insufficient biasing of the output current source and consequently unpredictable or no operation. Accordingly, we have installed an internal output/load-voltage monitoring circuit. If the output/load voltage drops below 2.5V and the DTL22A-LC's output is at risk of becoming disabled, the Fault line activates.

The Fault line is an active-low function with an open-collector output (internal 10kΩ pull-up resistor to +5V). Under normal conditions, its output is high (logic "1"). Under fault conditions ( $V_{OUT} < 0.6V$ ), its output drops to a logic "0." There is no output/load-voltage monitoring circuit for voltages greater than 50V, and operation above 50V can damage the device.

An "offset supply" can be inserted between the DTL22A-LC's -Load output (pins 8 and 9) and the power device under test (DUT) to "translate" the DTL22A-LC's 49.4V output/load voltage range. The offset supply must have adequate current capabilities and be connected with the polarities indicated in Figure 2 below. Under no circumstances should the voltage across the DTL22A-LC's output be allowed to experience a polarity reversal.

If a 5V/20A offset supply is inserted as shown, the range of DUT voltages will be -4.4 to +45 Volts. Such a configuration can be used for true short-circuit testing. A mechanical relay can be used to short the outputs of the DUT while the offset supply ensures the DTL22A-LC always sees at least 5 Volts across its outputs.

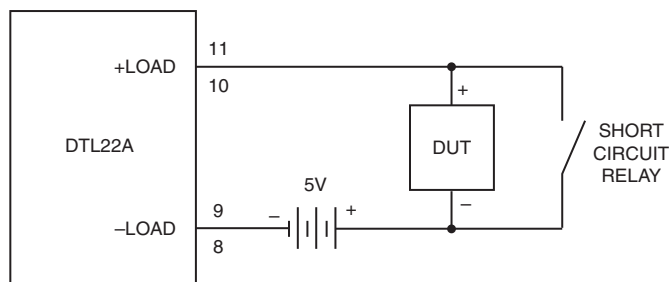

**Figure 2. An "Offset Supply" Enables True Short-Circuit Testing**

**Thermal Considerations**

The DTL22A-LC can reliably handle 100W loads if its aluminum baseplate temperature is maintained at or below +50°C. With no heat sinking or auxiliary cooling, the device can only handle loads up to 10 Watts. Please refer to the Temperature Derating Curve for additional information. DATEL's Electronic Load Applications Engineers can assist you in developing heat-sink solutions for your higher-power DTL22A-LC applications. Contact us for details about our DTL-HS100D12 heat sinks.

**Constant-Resistance Application**

The DTL22A-LC operates as a constant-current electronic load in its typical configuration. A constant-resistance mode of operation can be achieved as follows:

The DTL22A-LC has a high-impedance, isolated analog input that permits the inputs to be connected directly across the load. The DTL22A-LC sinks 20 Amps for a 10 Volt full-scale input or  $I = 2 \times V_{IN}$ . If you make  $V_{IN} = V_{LOAD}$ , (the voltage across the load), then  $R = V_{LOAD} / I = V_{LOAD} / (2 \times V_{LOAD}) = 0.5$  Ohms. Consequently, the load looks like a 0.5 Ohm resistor.

Furthermore, if you make  $V_{IN} = k \times V_{LOAD}$  by connecting a potentiometer or resistive divider across the load, then  $R = V_{LOAD} / (2 \times k \times V_{LOAD}) = 0.5/k$ . Adjusting the potentiometer effectively gives you an adjustable power resistor. At  $k = 0.5$ ,  $R = 1$  Ohm; at  $k = 0.25$ ,  $R = 2$  Ohms, etc. The only limitations you must observe are the maximum load voltage (50V) and the maximum 100 Watt power dissipation. A multiplying digital-to-analog converter or a digital potentiometer can also be used to effectively make a programmable resistance.

