

OBSOLETE



FEATURES

- RoHS compliant
- 7:1 Wide range voltage input, 9-60V_{DC}
- Operating temperature range -40°C to 85°C
- 0.05% Typical load regulation
- 1kVDC Isolation
- Efficiency from 79% at 36V_{IN}
- UL 94V-0 Package materials
- Low noise

PRODUCT OVERVIEW

The NDW3 series is particularly suitable for use in applications in railway, industry or telecommunication where variable input voltages are present. With an ultra wide input voltage range of 9-60VDC, the NDW3 series is suitable for use with nominal 12V, 24V or 48V systems.

The NDW3 is housed in an industry standard package with a standard pinout. The NDW3 is packaged in a metal case for improved EMI shielding and is also encapsulated for superior thermal performance..

SELECTION GUIDE

Order Code	Input Voltage V (Nom.)	Output Voltage V	Input Current		Output Current		Efficiency (Min.) %	MTTF ¹ kHrs
			0% Load mA	100% Load mA	Minimum Load mA	Maximum Load mA		
NDW3S3612C	36	12	8	104	62.5	250	79	1000

INPUT CHARACTERISTICS

Parameter	Conditions	Min.	Typ.	Max.	Units
Voltage range		9		60	V
Reflected ripple current	36V input with 10µF at input		60		mA p-p

OUTPUT CHARACTERISTICS

Parameter	Conditions	Min.	Typ.	Max.	Units
Rated power				3	W
Voltage set point accuracy	With external input/output capacitors		±2	±2.5	%
Line regulation	Low line to high line		0.03	0.2	%
Load regulation	25% total load to 100% load		0.05	0.2	%
Ripple	BW=20Hz to 300kHz, with external input/output capacitors		20	30	mVrms
Noise	BW=DC to 20MHz, with external input/output capacitors		70	150	mVp-p

ISOLATION CHARACTERISTICS

Parameter	Conditions	Min.	Typ.	Max.	Units
Isolation test voltage	Flash tested for 1 second	1000			VDC
Resistance	Viso = 1kVDC	1			GΩ
Capacitance			190		pF

GENERAL CHARACTERISTICS¹

Parameter	Conditions	Min.	Typ.	Max.	Units
Switching frequency	100% load to 25% total load	20		260	kHz

TEMPERATURE CHARACTERISTICS

Parameter	Conditions	Min.	Typ.	Max.	Units
Operation		-40		85	°C
Storage		-50		125	
Case temperature rise above ambient	100% Load, Nom V _{IN} , still air		16		

ABSOLUTE MAXIMUM RATINGS

Short-circuit protection	Momentary
Lead temperature 1.0mm from case for 10 seconds (to JEDEC JESD22-B106 ISS C)	260°C
Minimum output load for specification	25% of rated load

1. Calculated using MIL-HDBK-217F FN2 with nominal input voltage at full load at T_A = 25°C.

All specifications typical at T_A=25°C, with recommended input/output capacitors (refer to application note), nominal input voltage and rated output current unless otherwise specified.



For full details go to
www.murata-ps.com/rohs

APPLICATION NOTES

External Capacitance

Although these converters will work without external capacitors, they are necessary in order to guarantee the full parametric performance over the full line and load range. All parts have been tested and characterised using the following values and test circuit.

Value	
C_{IN}	C_{OUT1}
10 μ F, 100V	10 μ F low ESR Electrolytic

Recommended Input & Output Capacitors

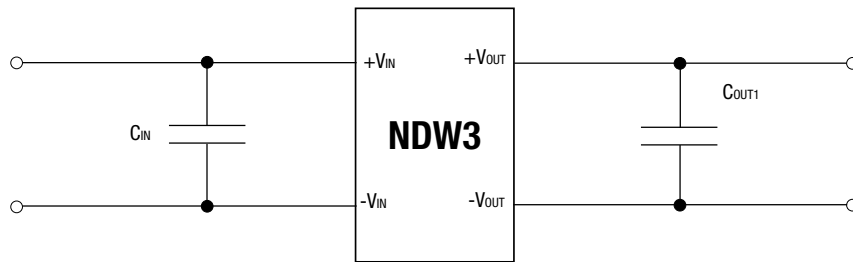

Output load

The minimum load for correct operation is 25% of the full rated load across the specified input voltage range. Lower loads may cause a significant increase in output ripple and may cause the output voltage to exceed its specification transiently during power-down when the input voltage also falls below its rated minimum.

TECHNICAL NOTES

ISOLATION VOLTAGE

'Hi Pot Test', 'Flash Tested', 'Withstand Voltage', 'Proof Voltage', 'Dielectric Withstand Voltage' & 'Isolation Test Voltage' are all terms that relate to the same thing, a test voltage, applied for a specified time, across a component designed to provide electrical isolation, to verify the integrity of that isolation.

Murata Power Solutions NDW3 series is 100% production tested at the stated isolation voltage. This is 1kVDC for 1 second.

A question commonly asked is, "What is the continuous voltage that can be applied across the part in normal operation?"

For a part holding no specific agency approvals, such as the NDW3 series, both input and output should normally be maintained within SELV limits i.e. less than 42.4V peak, or 60VDC. The isolation test voltage represents a measure of immunity to transient voltages and the part should never be used as an element of a safety isolation system. The part could be expected to function correctly with several hundred volts offset applied continuously across the isolation barrier; but then the circuitry on both sides of the barrier must be regarded as operating at an unsafe voltage and further isolation/insulation systems must form a barrier between these circuits and any user-accessible circuitry according to safety standard requirements.

REPEATED HIGH-VOLTAGE ISOLATION TESTING

It is well known that repeated high-voltage isolation testing of a barrier component can actually degrade isolation capability, to a lesser or greater degree depending on materials, construction and environment. The NDS3 series has an EI ferrite core, with no additional insulation between primary and secondary windings of enameled wire. While parts can be expected to withstand several times the stated test voltage, the isolation capability does depend on the wire insulation. Any material, including this enamel (typically polyurethane) is susceptible to eventual chemical degradation when subject to very high applied voltages thus implying that the number of tests should be strictly limited. We therefore strongly advise against repeated high voltage isolation testing, but if it is absolutely required, that the voltage be reduced by 20% from specified test voltage.

This consideration equally applies to agency recognized parts rated for better than functional isolation where the wire enamel insulation is always supplemented by a further insulation system of physical spacing or barriers.

RoHS COMPLIANCE INFORMATION



This series is compatible with RoHS soldering systems with a peak wave solder temperature of 260°C for 10 seconds. The pin termination finish on this product series is a Gold flash (0.05-0.10 micron) over Nickel Preplate. The series is backward compatible with Sn/Pb soldering systems.

For further information, please visit www.murata-ps.com/rohs

CHARACTERISATION TEST METHODS

Ripple & Noise Characterisation Method

Ripple and noise measurements are performed with the following test configuration.

C1	1uF X7R multilayer ceramic capacitor, voltage rating to be a minimum of 3 times the output voltage of the DC/DC converter
C2	10uF tantalum capacitor, voltage rating to be a minimum of 1.5 times the output voltage of the DC/DC converter with an ESR of less than 100mΩ at 100 kHz
C3	100nF multilayer ceramic capacitor, general purpose
R1	450Ω resistor, carbon film, +/-1% tolerance
R2	50Ω BNC termination
T1	3T of the coax cable through a ferrite toroid
RLOAD	Resistive load to the maximum power rating of the DC/DC converter. Connections should be made via twisted wires

Measured values are multiplied by 10 to obtain the specified values.

Differential Mode Noise Test Schematic

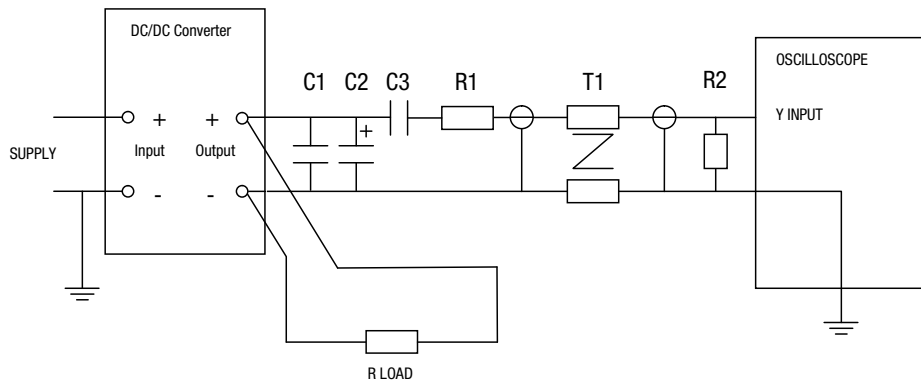

PACKAGE SPECIFICATIONS

MECHANICAL DIMENSIONS

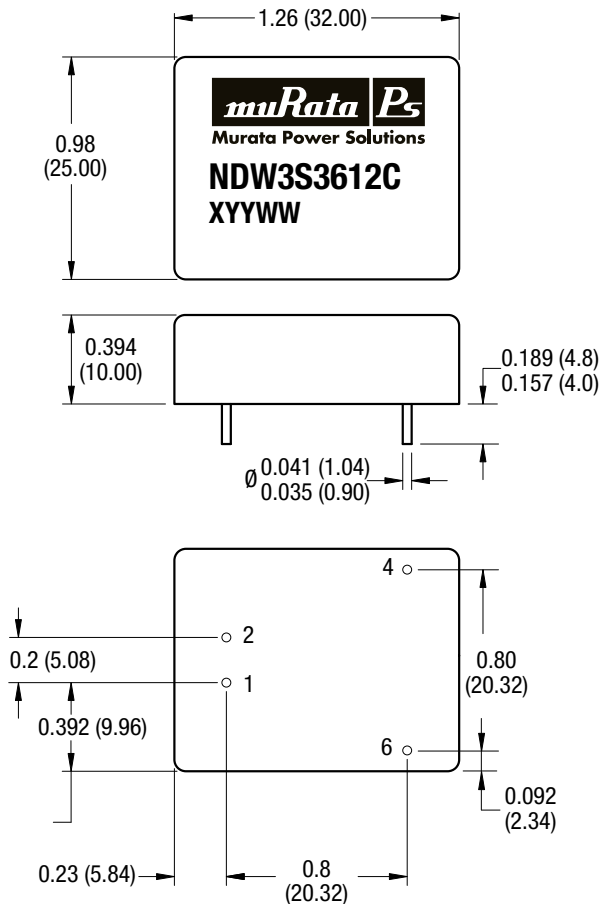

* Optional pin
 All dimensions in inches ± 0.010 (mm 0.25mm).
 All pins on a 0.100 (2.54) pitch and within 0.010 (0.25) of true position.

Weight: 20g

The copper case is connected to the output (-V_{OUT}) pin. Care is needed in the design of this circuit board on which the converter is mounted. Top side tracks must not contact the edge of the case on the underside of the unit.

PIN CONNECTIONS

Pin	Function
1	-V _{IN}
2	+V _{IN}
4	+V _{OUT}
6	-V _{OUT}

RECOMMENDED FOOTPRINT DETAILS

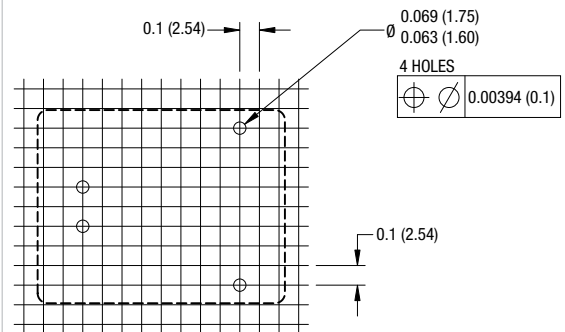

All dimensions in inches ± 0.010 (mm 0.25mm).

TUBE OUTLINE DIMENSIONS

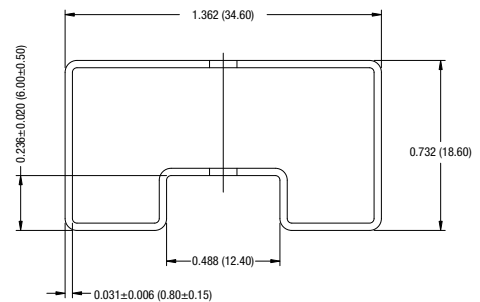

All dimensions in inches ± 0.010 (mm 0.25mm), unless specified otherwise.

Quantity: 15

Murata Power Solutions, Inc.
 11 Cabot Boulevard, Mansfield, MA 02048-1151 U.S.A.
 ISO 9001 and 14001 REGISTERED



This product is subject to the following **operating requirements** and the **Life and Safety Critical Application Sales Policy**:
 Refer to: <http://www.murata-ps.com/requirements/>

Murata Power Solutions, Inc. makes no representation that the use of its products in the circuits described herein, or the use of other technical information contained herein, will not infringe upon existing or future patent rights. The descriptions contained herein do not imply the granting of licenses to make, use, or sell equipment constructed in accordance therewith. Specifications are subject to change without notice.
 © 2013 Murata Power Solutions, Inc.