

OBSOLETE PRODUCT

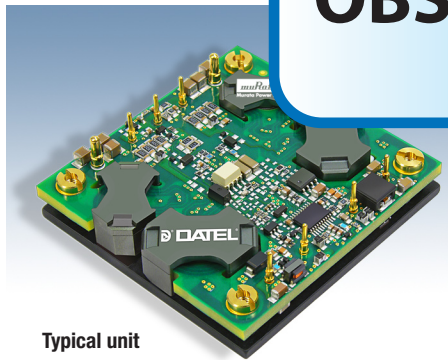

Typical unit

FEATURES

- Wide 36-75V input range
- 28.2V output @ 12 Amps. max.
- Very high efficiency of 91.5%
- Operates to +110°C baseplate w/derating
- Conduction-cooled baseplate, no fans
- Industry-standard mounting and pinout
- Remote sense, trim and On/Off control
- Isolated to 2250Vdc (Basic insulation)
- Multiple I/O protection features
- UL/EN60950-1 safety approvals, CE mark
- ETSI 300-019-2-4 surge, shock/vibration

DESCRIPTION

The UHP-28.2/12-D48 is especially designed for unattended cellular and PCS base stations, remote wide band RF amplifiers and wireless communication facilities. To avoid unreliable system fans, the UHP-28.2/12-D48 can be operated using conduction cooling while attached to a housing wall or system heat sink. No forced airflow is needed up to +110°C baseplate temperature.

The UHP-28.2/12-D48's MTBF is 3 million hours (+40°C GF) and ruggedization conforms to ETSI 300-019-2-4. Multiple protection features avoid damage to outside equipment and to the converter itself. The converter will shut down on sustained input undervoltage, output overcurrent, output short circuit and overvoltage and thermal shutdown. Overload currents less than a short circuit limit the output current so that operation

INPUT CHARACTERISTICS

| Parameter | Typ. @ 25°C, full load | Notes |
|------------------------------|------------------------|----------------------------|
| Voltage Range | 36-75 Volts | 48V nominal |
| Current, full power | 5.77 Amps | V _{IN} = 48V |
| Undervoltage Shutdown | 32 Volts | |
| Short Circuit Current | 200mA | V _{IN} = 48V |
| Remote On/Off Control | 0 to +V _{IN} | Positive or negative logic |

OUTPUT CHARACTERISTICS

| Parameter | Typ. @ 25°C, full load | Notes |
|-----------------------------------|------------------------|------------------------------|
| Voltage | 28.2 Volts ±10% | Trim range shown |
| Current | 0 to 12 Amps | No minimum load |
| Power Output | 342 Watts max. | Max. baseplate @ 342W = 80°C |
| Accuracy | ±1.25% | |
| Ripple & Noise | 100mVp-p | 20MHz bandwidth |
| Line and Load Regulation | ±0.05%/±0.1% | |
| Overcurrent Protection | 30 Amps | With hiccup auto-restart |
| Overtemperature Protection | +125°C | |
| Efficiency (minimum) | 89.5% | |
| Efficiency (typical) | 91.5% | |

GENERAL SPECIFICATIONS

| Parameter | Typ. @ 25°C, full load | Notes |
|------------------------------------|------------------------|-------------------------------------|
| Dynamic Load Response | 100µsec | 50-75-50% step to ±1 of final value |
| Operating Temperature Range | -40 to +110°C | With baseplate, see derating curve |
| Operating Temperature Range | -40 to +32°C | Without baseplate |
| Safety | UL/IEC/EN 60950-1 | And CSA C22.2-No.234 |

MECHANICAL CHARACTERISTICS

| | |
|-------------------|--|
| With baseplate | 2.30 x 2.40 x 0.502 inches (58.4 x 61.0 x 12.8 mm) |
| Without baseplate | 2.30 x 2.40 x 0.452 inches (58.4 x 61.0 x 11.5 mm) |

is not interrupted. Upon short circuit shutdown, the converter will automatically attempt to restart ("hiccup" mode) when the overload is removed. The input will tolerate up to 100V overvoltage spikes (100msec).

The UHP-28.2/12-D48 uses industry-standard half-brick external outline dimensions, pinout and mechanical mounting. The overall unit is designed to be as "lead-free" as practical in construction and method of attachment (no lead added in assembly).

PERFORMANCE SPECIFICATIONS AND ORDERING GUIDE ^①

| Model | Output | | | | | | Input | | | Efficiency | | Package (Case/ Pinout) |
|-----------------|--------------------------|-------------------------|--------------------------|------|------------|-------------------|------------------------------|---------------|-------------------------------------|------------|-------|------------------------|
| | V _{OUT} (Volts) | I _{OUT} (Amps) | R/N (mVp-p) ^② | | Regulation | | V _{IN} Nom. (Volts) | Range (Volts) | I _{IN} ^④ (mA/A) | Min. | Typ. | |
| | | | Typ. | Max. | Line | Load ^③ | | | | | | |
| UHP-28.2/12-D48 | 28.2 | 12 | 100 | 160 | ±0.05% | ±0.1% | 48 | 36-75 | 75/7.06 | 89.5% | 91.5% | C66, P17 |

- ① Typical at T_A = +25°C under nominal line voltage and full-load conditions, unless noted.
- ② Ripple/Noise (R/N) is measured over a 20MHz bandwidth and input filter.
- ③ Regulation is tested no load to 100% load.
- ④ Nominal line voltage, no-load/full-load conditions.

PART NUMBER STRUCTURE

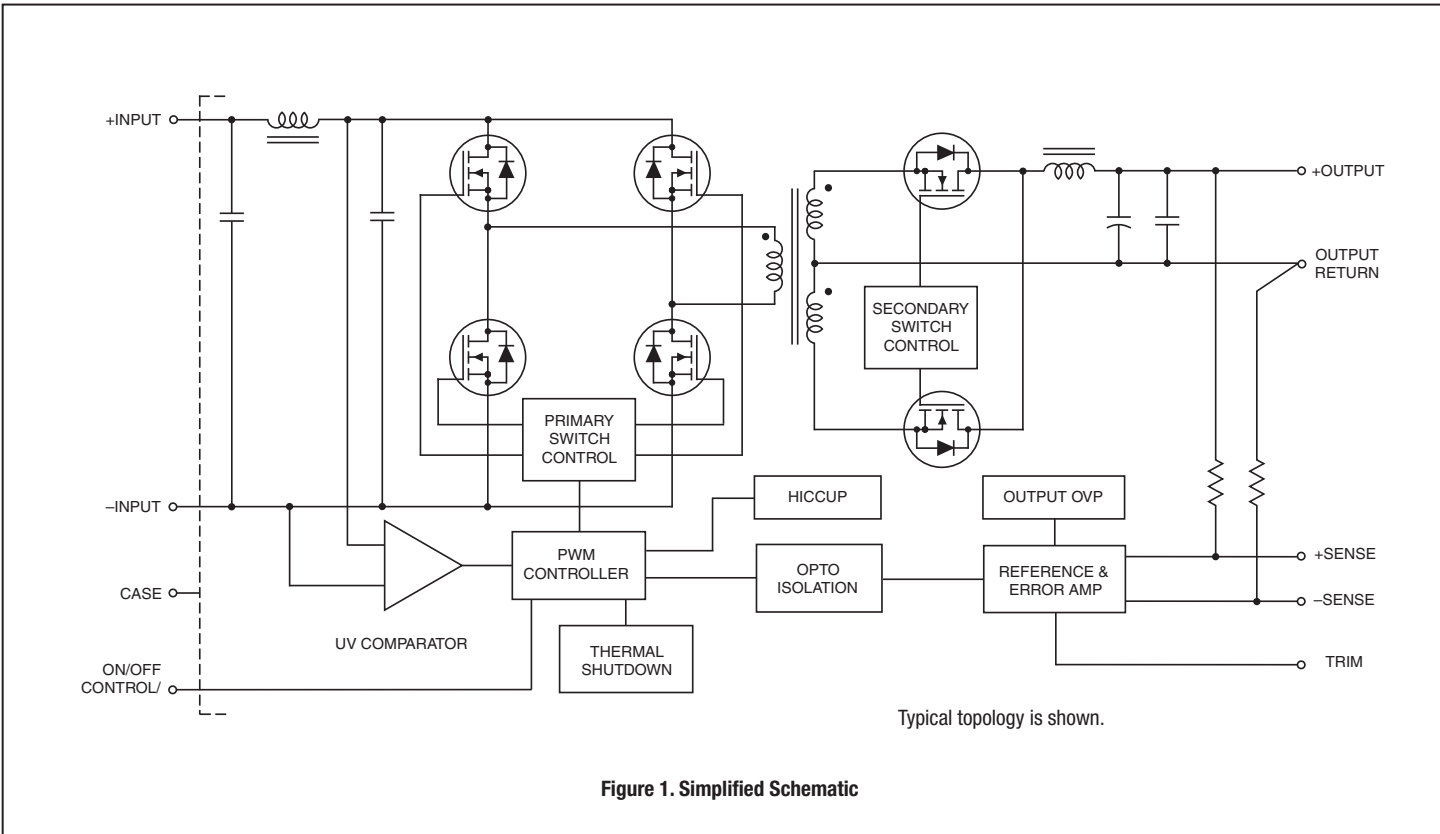
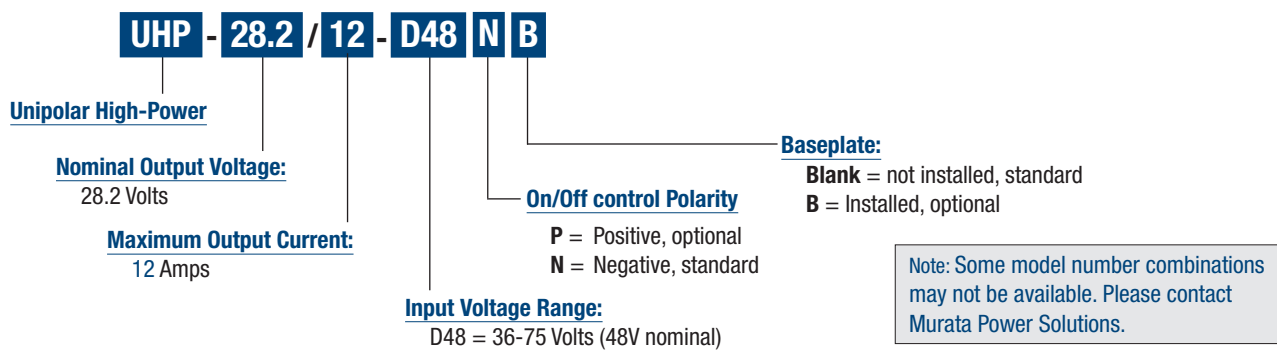

Figure 1. Simplified Schematic

Typical topology is shown.

Performance/Functional Specifications

Typical @ TA = +25°C under nominal line voltage, full-load conditions, unless noted. ⁽¹⁾

| Input | |
|--|---|
| Input Voltage Range | See Ordering Guide |
| Start-Up Threshold | 34 Volts |
| Undervoltage Shutdown | 32 Volts |
| Voltage Transients (100msec, no damage) | +100 Volts max. |
| Overvoltage Shutdown | None ⁽⁷⁾ |
| Reflected (Back) Ripple Current ⁽²⁾ | 50mA _{p-p} |
| Input Current: | |
| Full Load Conditions | See Ordering Guide |
| Inrush Transient | 1A ² sec |
| Output Short Circuit | 200mA |
| No Load | 75mA |
| Low Line (VIN = VMIN) | 9.37 Amps |
| Standby Mode | 10mA max. |
| (Off, UV, OT, OC shutdown) | |
| Internal Input Filter | Pi-type |
| Recommended External Fuse | 18 Amps slow blow |
| Reverse Polarity Protection | See fuse information |
| Remote On/Off Control: ⁽⁵⁾ | |
| Positive Logic ("P" model suffix) | ON = open pin or +2.8V to +12V max. OFF = ground pin to +0.8V max. |
| Negative Logic ("N" model suffix) | ON = ground pin to +0.8V max. OFF = open pin or +2.8V to +12V max. |
| Current | 1mA |
| Output | |
| Total Output Power | 342 Watts max. |
| Voltage Output Range | See Ordering Guide |
| Voltage Output Accuracy | ±1 % of Vnominal |
| Overvoltage Protection ⁽¹⁴⁾ | +125% of Vout nominal |
| Method | Magnetic feedback |
| Voltage Adjustment Range ⁽¹²⁾ | +25.4V min. to +31V max. |
| Temperature Coefficient | ±0.02% of Vout range per °C |
| Minimum Loading | No minimum load |
| Remote Sense Compensation | +1% max. |
| Ripple/Noise (20 MHz bandwidth) | See Ordering Guide ⁽⁶⁾ |
| Line/Load Regulation | See Ordering Guide and note ⁽¹⁰⁾ |
| Efficiency | See Ordering Guide |
| Maximum Capacitive Loading (Resistive) | 3300µF (Low ESR <0.02Ω max.) |
| Isolation Voltage: | |
| Input to Output | 2250Vdc min. |
| Input to Baseplate | 1500Vdc min. |
| Baseplate to Output | 750Vdc min. |
| Isolation Resistance | 100MΩ |
| Isolation Capacitance | 2000 pF |
| Isolation Safety Rating | Basic insulation |
| Current Limit Inception (98% of Vout) | 16 Amps at cold start 15 Amps after warmup |
| Short Circuit ⁽⁶⁾ | |
| Protection Method | Current limiting with hiccup autorestart |
| Short Circuit Current | TBD |
| Short Circuit Duration | Continuous, output shorted to ground (no damage) |

| Dynamic Characteristics | |
|---|---|
| Dynamic Load Response (50-75-50%step) | 100µsec to ±1% of final value |
| Load Step Peak Deviation | ±600mV |
| Start-Up Time | 360msec for Vout = nominal |
| (VIN on to Vout regulated or On/Off to Vout) | |
| Switching Frequency | 320kHz |
| Environmental | |
| Calculated MTBF ⁽⁴⁾ | >3,000,000 Hours |
| Baseplate Temperature Range | -40 to +110°C max. |
| (See derating curve) ⁽³⁾ ⁽¹³⁾ | |
| Storage Temperature Range | -55 to +125°C |
| Thermal Protection/Shutdown ⁽¹³⁾ | +115°C |
| Relative Humidity | To 85% / +85°C, non-condensing |
| Acoustic Output 20Hz to 20kHz | No audible output in normal office environments ⁽¹⁵⁾ |
| Physical | |
| Outline Dimensions | See Mechanical Specifications |
| Baseplate Material | Aluminum |
| Pin Material | Copper alloy |
| Weight | 3.9 ounces (110 grams) |
| Electromagnetic Interference | FCC part 15, class B, EN55022 (external filter required) |
| Safety | UL/cUL 60950-1 CSA-C22.2 No.234 IEC/EN 60950 UL1012 |
| Surge, Shock, Vibration | ETSI 300-019-2-4 |
| Flammability | UL94-0 |

Absolute Maximum Ratings

| | |
|--|--|
| Input Voltage | |
| Continuous | to +75V |
| Transient (100 msec max.) | to +100V |
| On/Off Control | -0.3 V min to +12V max. |
| Input Reverse Polarity Protection | See Fuse section ⁽¹¹⁾ |
| Output Overvoltage | Vout +25% max. |
| Output Current ⁽⁷⁾ | Current-limited. Devices can withstand sustained short circuit without damage. |
| Storage Temperature | -55 to +125°C |
| Lead Temperature (soldering 10 sec. max.) | +280°C |
| These are stress ratings. Exposure of devices to any of these conditions may adversely affect long-term reliability. Proper operation under conditions other than those listed in the Performance/Functional Specifications Table is not implied, nor recommended. | |

Performance/Functional Specification Notes:

- The UHP-28.2/12-D48 is tested and specified with external 1 || 10 µF ceramic/tantalum output capacitors and a 22µF external input capacitor. All capacitors are low ESR types. These capacitors are necessary to accommodate our test equipment and may not be required to achieve specified performance in your applications. All models are stable and regulate within spec under no-load conditions.
General conditions for Specifications are +25°C, VIN = nominal, Vout = nominal, full load.
- Input Ripple Current is tested and specified over a 5Hz to 20MHz bandwidth. Input filtering is CIN = 33µF tantalum, Cbus = 220µF electrolytic, Lbus = 12µH.

Performance/Functional Specification Notes:

- (3) Note that Maximum Power Derating curves indicate an average current at nominal input voltage. At higher temperatures and/or lower airflow, the DC/DC converter will tolerate brief full current outputs if the total RMS current over time does not exceed the Derating curve.
- (4) Mean Time Before Failure is calculated using the Telcordia (Belcore) SR-332 Method 1, Case 3, ground fixed conditions, T_{CASE} = +40°C, full output load, natural air convection.
- (5) The On/Off Control may be driven with external logic or by applying appropriate external voltages which are referenced to Input Common. The On/Off Control Input should use either an open collector/open drain transistor or logic gate which does not exceed +12V.
- (6) Short circuit shutdown begins when the output voltage degrades approximately 2% from the selected setting. Remove overload for recovery.
- (7) Input overvoltage shutdown is explicitly not included to improve system reliability in datacom and telecom applications. These requirements attempt continued operation despite significant input overvoltage.
- (8) Output noise may be further reduced by adding an external filter. See I/O Filtering and Noise Reduction. Use only as much external output filtering as needed and no more. Larger caps (especially low-ESR ceramic types) may degrade dynamic performance or cause possible failed starts. Thoroughly test your application with all components installed.
- (9) Models are fully operational and meet published specifications, including "cold start" at -40°C.
- (10) Regulation specifications describe the deviation as the line input voltage or output load current is varied from a nominal midpoint value to either extreme.
- (11) If the input voltage is reversed, a normally back-biased bulk substrate diode will become forward biased and draw current. An external fuse is recommended to avoid damage from reverse input current.
- (12) Do not exceed maximum power specifications when adjusting the output trim.
- (13) Note that the converter may operate derated up to +110°C with the baseplate installed. However, thermal self-protection occurs near +115°C and there is a thermal gradient from the hotspot to the baseplate. Therefore, +110°C is recommended to avoid thermal shutdown.
- (14) If the output exceeds the Overvoltage specification, the output will shut down in latching mode. To restore normal operation, either power down the unit or cycle the On/Off control.
- (15) Acoustic output is measured by subjecting the converter to both 0-100-0% and 50-100-50% step loads at load pulse frequencies of 100Hz, 300Hz and 1kHz.

TECHNICAL NOTES

Input Fusing

Certain applications and/or safety agencies may require the installation of fuses at the inputs of power conversion components. Fuses should also be used if the possibility of sustained, non-current-limited, input-voltage polarity reversals exists. For DATEL UHP Series DC/DC Converters, we recommend the use of slow-blow type fuses, installed in the ungrounded input supply line, with values no greater than the following.

| Output | Fuse Value |
|---------------------|------------|
| 28 V _{OUT} | 18 Amp |

All relevant national and international safety standards and regulations must be observed by the installer. For system safety agency approvals, the converters must be installed in compliance with the requirements of the end-use safety standard, i.e. IEC/EN/UL60950.

Input Undervoltage Shutdown and Start-Up Threshold

Under normal start-up conditions, devices will not begin to regulate properly until the ramping-up input voltage exceeds the Start-Up Threshold Voltage. Once operating, devices will not turn off until the input voltage drops below the Undervoltage Shutdown limit. Subsequent re-start will not occur until the input is brought back up to the Start-Up Threshold. This built in hysteresis prevents any unstable on/off situations from occurring at a single input voltage.

Start-Up Time

The V_{IN} to V_{OUT} Start-Up Time is the interval of time between the point at which the ramping input voltage crosses the Start-Up Threshold and the fully loaded output voltage enters and remains within 90% of V_{OUT}. Actual measured times will vary with input source impedance, external input capacitance, and the slew rate and final value of the input voltage as it appears at the converter. The UHP Series implements a soft start circuit that limits the duty cycle of its PWM controller at power up, thereby limiting the input inrush current.

The On/Off Control to V_{OUT} start-up time assumes the converter has its nominal input voltage applied but is turned off via the On/Off Control pin. The specification defines the interval between the point at which the converter is turned on (released) and the fully loaded output voltage enters and remains within its specified accuracy band.

Similar to the V_{IN} to V_{OUT} start-up, the On/Off Control to V_{OUT} start-up time is also governed by the internal soft start circuitry and external load capacitance. The difference in start up time from V_{IN} to V_{OUT} and from On/Off Control to V_{OUT} is therefore insignificant.

Input Overvoltage Shutdown

The UHP Series does not feature input overvoltage shutdown. The converters do withstand and fully operate during input transients to 100V for 100msec without interruption; consequently, this function has been disabled.

Input Source Impedance

The input of UHP converters must be driven from a low ac-impedance source. The DC/DC's performance and stability can be compromised by the use of highly inductive source impedances. The input circuit shown in Figure 2 is a practical solution that can be used to minimize the effects of inductance in the input traces. For optimum performance, components should be mounted as close as possible to the DC/DC converter.

I/O Filtering, Input Ripple Current, and Output Noise

All models in the UHP Series are tested/specified for input reflected ripple current and output noise using the specified external input/output components/circuits and layout as shown in the following two figures.

External input capacitors (C_{IN} in Figure 2) serve primarily as energy-storage elements, minimizing line voltage variations caused by transient IR drops in conductors from backplane to the DC/DC. Input caps should be selected for bulk capacitance (at appropriate frequencies), low ESR, and high rms-ripple-current ratings. The switching nature of DC/DC converters requires that dc voltage sources have low ac impedance as highly inductive source impedance can affect system stability. In Figure 2, C_{BUS} and L_{BUS} simulate a typical dc voltage bus. Your specific system configuration may necessitate additional considerations.

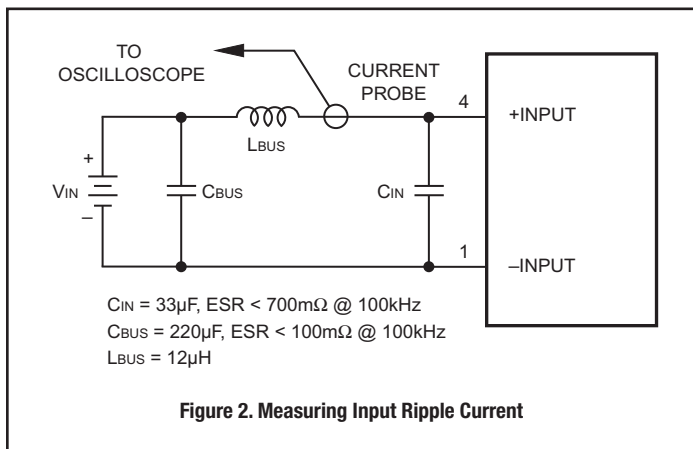

Figure 2. Measuring Input Ripple Current

In critical applications, output ripple/noise (also referred to as periodic and random deviations or PARD) may be reduced below specified limits using filtering techniques, the simplest of which is the installation of additional external output capacitors. They function as true filter elements and should be selected for bulk capacitance, low ESR and appropriate frequency response. All external capacitors should have appropriate voltage ratings and be located as close to the converter as possible. Temperature variations for all relevant parameters should also be taken carefully into consideration.

The most effective combination of external I/O capacitors will be a function of line voltage and source impedance, as well as particular load and layout conditions. Our Applications Engineers can recommend potential solutions and discuss the possibility of our modifying a given device's internal filtering to meet your specific requirements. Contact our Applications Engineering Group for additional details.

In Figure 3, the two copper strips simulate real-world PCB impedances between the power supply and its load. In order to minimize measurement errors, scope measurements should be made using BNC connectors, or the probe ground should be as short as possible (i.e. less than 1/2 inch) and soldered directly to the fixture.

Floating Outputs

Since these are isolated DC/DC converters, their outputs are "floating" with respect to their input. Designers will normally use the -Output (pin 9) as the ground/return of the load circuit. You can however, use the +Output (pin 5) as ground/return to effectively reverse the output polarity.

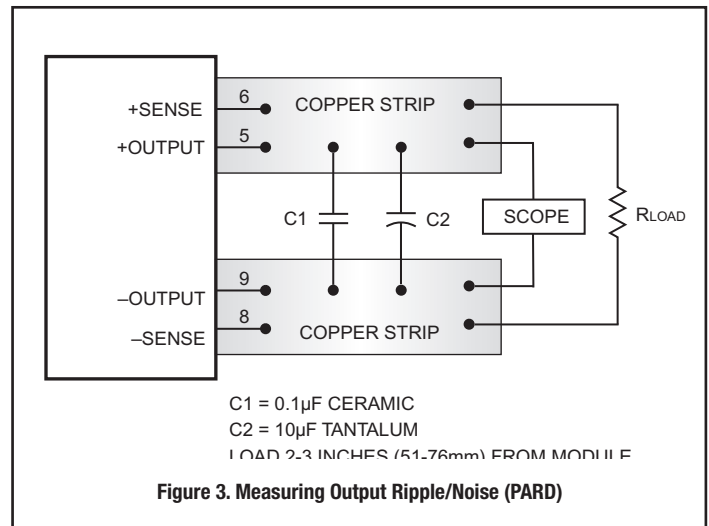

Figure 3. Measuring Output Ripple/Noise (PARD)

Minimum Output Loading Requirements

UHP converters employ a synchronous-rectifier design topology and all models regulate within spec and are stable under no-load to full load conditions. Operation under no-load conditions however might slightly increase the output ripple and noise.

Thermal Shutdown

The UHP converters are equipped with thermal-shutdown circuitry. If environmental conditions cause the temperature of the DC/DC converter to rise above the designed operating temperature, a precision temperature sensor will power down the unit. When the internal temperature decreases below the threshold of the temperature sensor, the unit will self start. See Performance/Functional Specifications.

Output Overvoltage Protection

The UHP output voltage is monitored for an overvoltage condition using a comparator. The signal is optically coupled to the primary side and if the output voltage rises to a level which could be damaging to the load, the sensing circuitry will power down the PWM controller causing the output voltage to decrease. Following a time-out period the PWM will restart, causing the output voltage to ramp to its appropriate value. If the fault condition persists, and the output voltage again climbs to excessive levels, the overvoltage circuitry will initiate another shutdown cycle. This on/off cycling is referred to as "hiccup" mode.

Current Limiting

As soon as the output current increases to approximately 125% of its rated value, the DC/DC converter will go into a current-limiting mode. In this condition, the output voltage will decrease proportionately with increases in output current, thereby maintaining somewhat constant power dissipation. This is commonly referred to as power limiting. Current limit inception is defined as the point at which the full-power output voltage falls below the specified tolerance. See Performance/Functional Specifications. If the load current, being drawn from the converter, is significant enough, the unit will go into a short circuit condition as described below.

Short Circuit Condition

When a converter is in current-limit mode, the output voltage will drop as the output current demand increases. If the output voltage drops too low, the magnetically coupled voltage used to develop primary side voltages will also drop, thereby shutting down the PWM controller. Following a time-out period, the PWM will restart causing the output voltage to begin ramping to their appropriate value. If the short-circuit condition persists, another shutdown cycle will be initiated. This on/off cycling is referred to as "hiccup" mode. The hiccup cycling reduces the average output current, thereby preventing internal temperatures from rising to excessive levels. The UHP Series is capable of enduring an indefinite short circuit output condition.

Features and Options

Remote Sense

Note: The Sense and V_{OUT} lines are internally connected through resistors (=10Ω). Nevertheless, if the sense function is not used for remote regulation the user should connect the +Sense to +V_{OUT} and -Sense to -V_{OUT} at the DC/DC converter pins.

UHP Series converters employ a sense feature to provide point of use regulation, thereby overcoming moderate IR drops in pcb conductors or cabling. The remote sense lines carry very little current and therefore require minimal cross-sectional-area conductors. The sense lines, which are capacitively coupled to their respective output lines, are used by the feedback control-loop to regulate the output. As such, they are not low impedance points and must be treated with care in layouts and cabling. Sense lines on a pcb should be run adjacent to dc signals, preferably ground. In cables and discrete wiring applications, twisted pair or other techniques should be implemented.

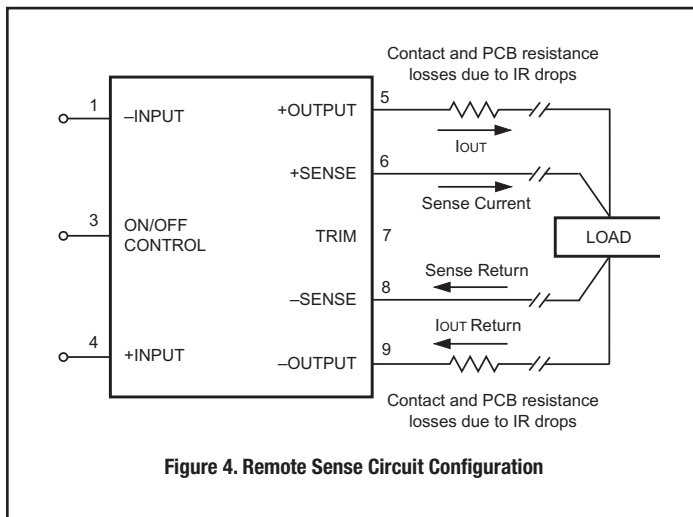

Figure 4. Remote Sense Circuit Configuration

UHP Series converters will compensate for drops between the output voltage at the DC/DC and the sense voltage at the DC/DC provided that:

$$[V_{OUT} (+) - V_{OUT} (-)] - [Sense (+) - Sense (-)] \leq 10\% V_{OUT}$$

Output overvoltage protection is monitored at the output voltage pin, not the Sense pin. Therefore, excessive voltage differences between V_{OUT} and Sense in conjunction with trim adjustment of the output voltage can cause the

overvoltage protection circuitry to activate (see Performance Specifications for overvoltage limits). Power derating is based on maximum output current and voltage at the converter's output pins. Use of trim and sense functions can cause output voltages to increase, thereby increasing output power beyond the converter's specified rating, or cause output voltages to climb into the output overvoltage region. Therefore, the designer must ensure:

$$(V_{OUT \text{ at pins}}) \times (I_{OUT}) \leq \text{rated output power}$$

On/Off Control

The primary-side, Remote On/Off Control function (pin 3) can be specified to operate with either positive or negative polarity. Positive-polarity devices ("P" suffix) are enabled when pin 3 is left open or is pulled high. Positive-polarity devices are disabled when pin 3 is pulled low (0-0.8V with respect to -Input). Negative-polarity devices are off when pin 3 is high/open and on when pin 3 is pulled low or grounded. See Figure 5.

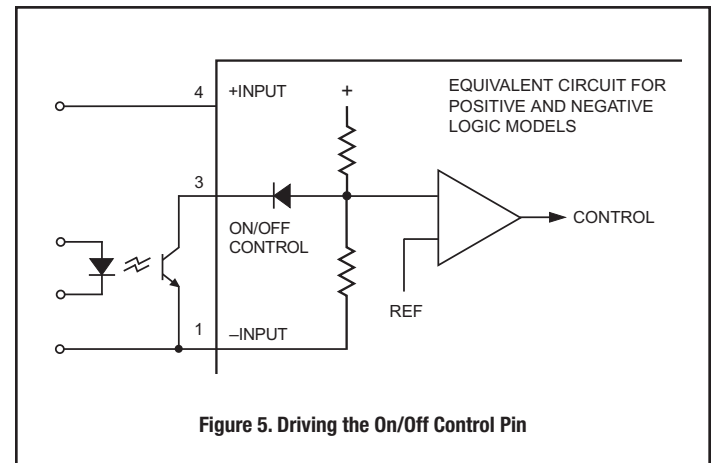

Figure 5. Driving the On/Off Control Pin

Dynamic control of the remote on/off function is best accomplished with a mechanical relay or an open-collector/open-drain drive circuit (optically isolated if appropriate). The drive circuit should be able to sink appropriate current (see Performance Specifications) when activated and withstand appropriate voltage when deactivated.

Trimming Output Voltage

UHP converters have a trim capability (pin 7) that allows users to adjust the output voltage within the specified range. Adjustments to the output voltages can be accomplished via a trim pot (Figure 6) or a single fixed resistor, shown in Figures 7 and 8. A single fixed resistor can increase or decrease the output voltage depending on its connection. The resistor should be located close to the converter and have a TCR less than 100ppm/°C to minimize sensitivity to temperature changes. If the trim function is not used, leave the trim pin floating.

A single resistor connected from the Trim (pin 7) to the +Sense (pin 6), will increase the output voltage (Figure 8). A resistor connected from the Trim (pin 7) to the -Sense (pin 8), will decrease the output voltage (Figure 9).

Trim adjustments greater than the specified range can have an adverse affect on the converter's performance and are not recommended. Excessive voltage differences between V_{OUT} and Sense, in conjunction with trim adjustment of the output voltage, can cause the overvoltage protection circuitry to activate (see Performance Specifications for overvoltage limits). Power derating is based on maximum output current and voltage at the converter's output

pins. Use of trim and sense functions can cause output voltages to increase, thereby increasing output power beyond the converter's specified rating or cause output voltages to climb into the output overvoltage region. Therefore:

$$(V_{OUT \text{ at pins}}) \times (I_{OUT}) = < \text{rated output power}$$

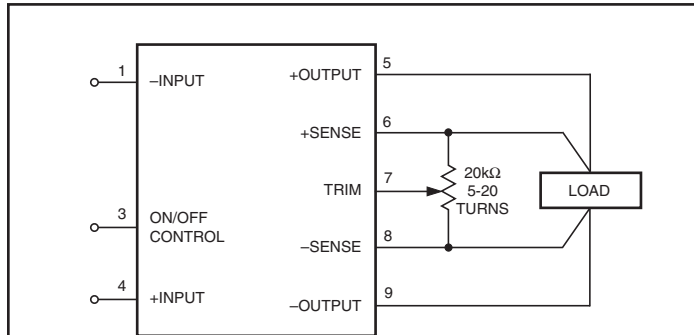

Figure 6. Trim Connections Using A Trim Pot

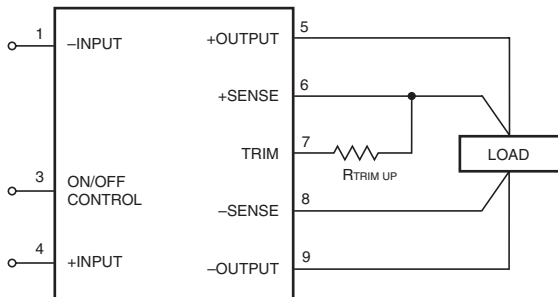

Figure 7. Trim Connections To Increase Output Voltages Using Fixed Resistors

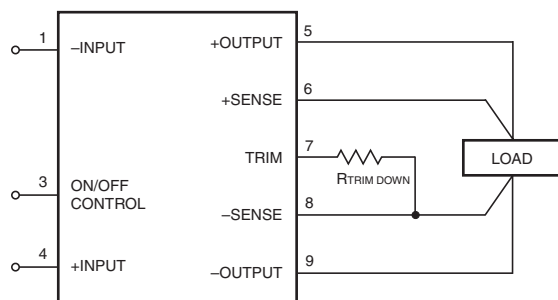

Figure 8. Trim Connections To Decrease Output Voltages Using Fixed Resistors

Trim Equations

$$R_{TUP} (k\Omega) = 10 \left(\frac{1036}{\Delta\%} \right) + 936 \quad R_{TDOWN} (k\Omega) = 10 \left(\frac{100}{\Delta\%} \right) - 2$$

where Δ% is the desired change of the output voltage in percent relative to V_{NOMINAL}. Or,

$$\pm\Delta\% = \frac{V_{OUT} - V_{NOM}}{V_{NOM}} \times 100$$

TYPICAL PERFORMANCE CURVES

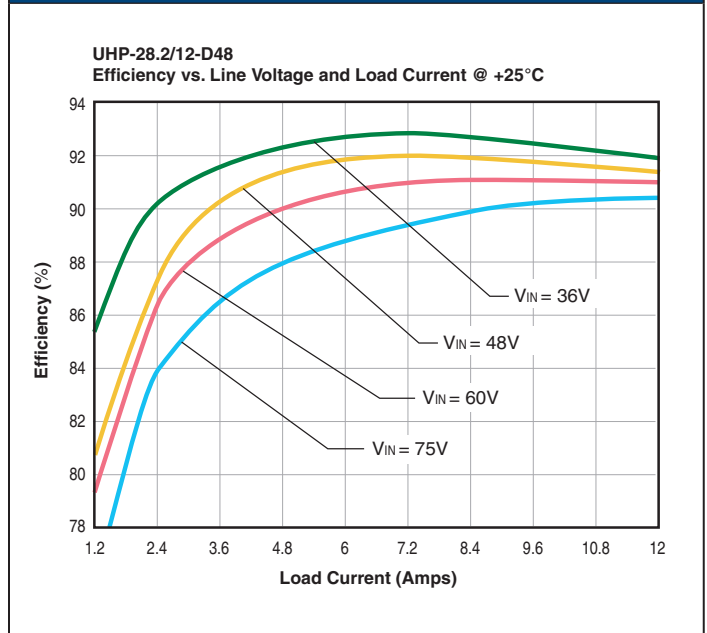

UHP Converter Series Mounting

The UHP series include a multilayer planar-magnetic Printed Circuit Board (PCB), high-current Input/Output pins, four removable brass mounting standoffs and an optional machined aluminum baseplate. See Mechanical Specifications.

A user's installation will normally have a host PCB to solder to the converter's I/O pins. To avoid placing the full mechanical mounting load on the I/O pins, we recommend that the user's PCB also includes bolts through the PCB to assemble to the standoffs. Note the #M3 metric threading of the standoffs. Avoid excessive torque assembling the bolts to the standoffs. Use lock washers or locking compound to avoid loosening of the mounting bolts.

The standoffs include machined shoulders so that mechanical force is not placed against the converter's power components. To avoid long-term oxidation of the host PCB, be sure to accommodate the relatively high temperatures of the power components adjacent to the user's host PCB. Normally, a planar grounded area of copper etch on the PCB surface will be sufficient to spread the heat, reduce electrical noise and avoid hotspots. A relief dimension on the standoffs floats the power components 0.02 inches minimum from the user's host PCB.

The baseplate is in thermal contact with the power components and practically all the converter's internal heat dissipation is conducted away via the baseplate. Users typically have two choices to remove this thermal load—either an extruded aluminum finned heat sink or a thermal mounting surface such as a chassis wall. The heatsink depends on ambient temperature, airflow and total power extracted from the converter, depending on the input voltage and converter efficiency. Do not attempt to conduct all baseplate heat solely through the standoffs. Use either a thermal pad or thermal mounting compound ("thermal grease") when attaching the baseplate to its mounting surface. Keep baseplate temperature below +110°C. Study the Derating Curve.

For chassis wall mounting, the user must consider the tolerance buildup—the host PCB, mounting standoffs, thermal pad and placement of the chassis wall. Measure carefully to avoid unwanted mechanical stresses.

MECHANICAL SPECIFICATIONS

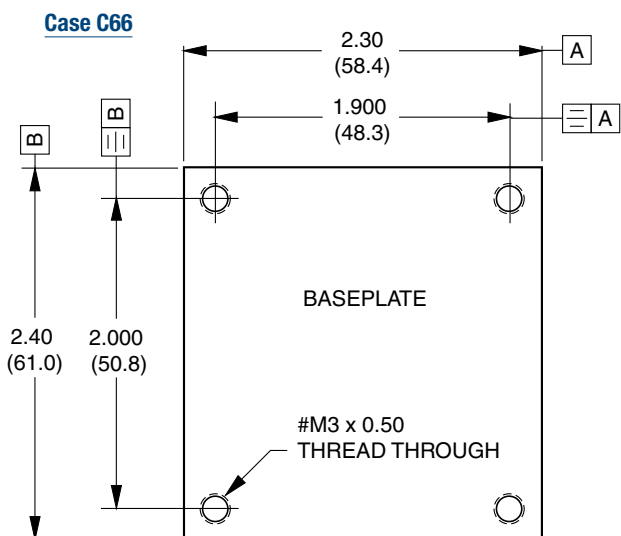

| I/O CONNECTIONS | |
|-----------------|----------------|
| Pin | Function P17 |
| 1 | -Input |
| 2 | Case |
| 3 | On/Off Control |
| 4 | +Input |
| 5 | +Output |
| 6 | +Sense |
| 7 | Trim |
| 8 | -Sense |
| 9 | -Output |

Connect each sense input to its respective Vout if sense is not connected at a remote load.

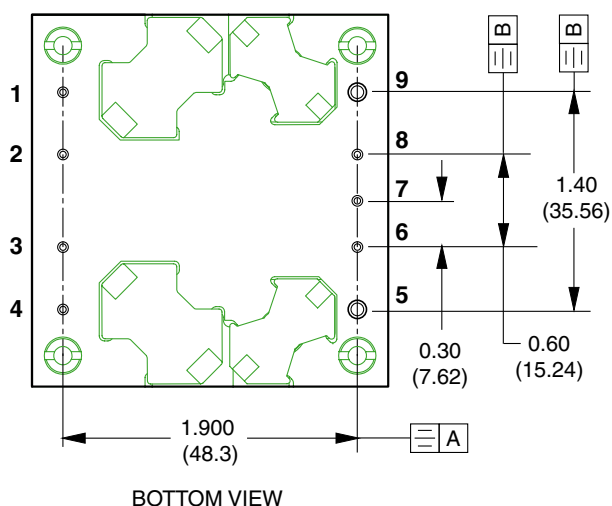
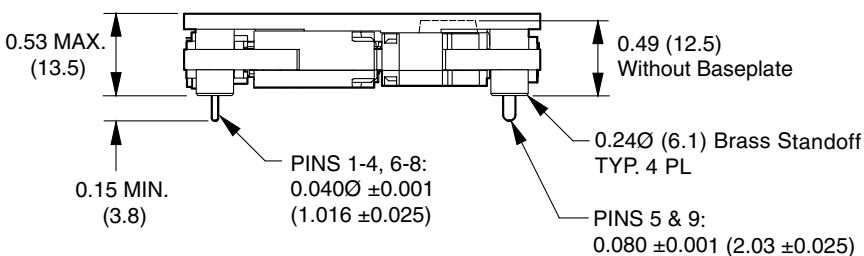

DIMENSIONS ARE IN INCHES (MM)

Dimensions are in inches (mm shown for ref. only).

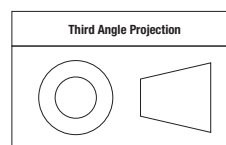

Tolerances (unless otherwise specified):
.XX ± 0.02 (0.5)
.XXX ± 0.010 (0.25)
Angles ± 2°

Components are shown for reference only.

Thermal Management

“Zero Airflow” Passive Cooling Enclosure Installations

The UHP-28.2/12-D48 converter will deliver its full rated power as long as the user maintains the baseplate at +80°C or less. Usable power is available derated up to +110°C baseplate temperature. Please see the “baseplate” Derating curve below. This curve is different from standard Derating curves because no airflow is indicated. This is a reflection of the requirement to only limit the baseplate temperature since the majority of the heat flows out through the baseplate. Some heat is removed via airflow convection over the converter.

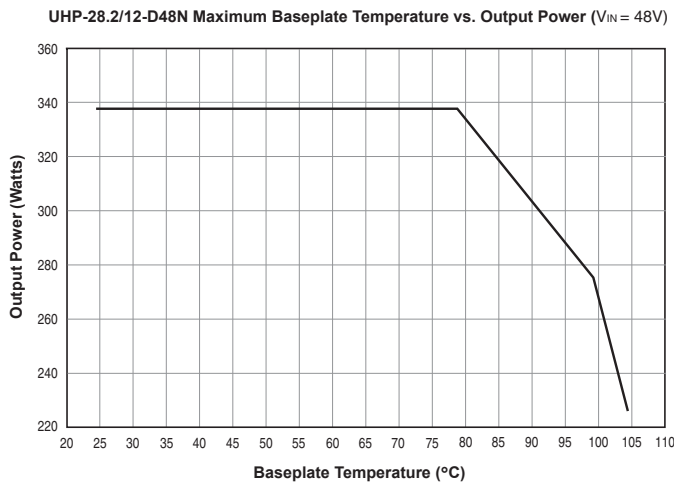

Figure 9. Maximum Baseplate Temperature vs. Output Power

“No airflow” applications are normally those with the converter bolted to a chassis wall or other large heat-conducting surface. For such wall installations, there is no explicit airflow specification and the converter may be used with zero airflow as long as the baseplate does not exceed +110°C.

Consider using thermal pads or compound (“thermal grease”) to lower the thermal resistance between the baseplate and the chassis wall. Do not rely only on the baseplate mounting screws to transfer heat. Also, since a housing wall is not an infinite heat sink, most real-world enclosure installations are improved by moderate forced airflow. This airflow cools both the mounting surface and the converter itself by convection. Larger area and/or a thicker mounting surface material will conduct more heat away and allow higher output power.

Because of the high efficiency of the converter, the mounting surface only carries away the internal dissipation of the converter, not the entire power output. For computation purposes, the enclosure surface may use the following dissipation equations:

$$P(\text{diss}) = \text{PowerIn} - \text{PowerOut} \text{ and,}$$

$$\text{PowerOut} / \text{PowerIn} \times 100 = \text{Efficiency (in \%)} \text{ and,}$$

$$P(\text{diss}) = \text{PowerIn} (1 - \text{Efficiency}/100)$$

where “P(diss)” is the internal power dissipation of the converter.

Efficiency is given in percent. For example, with 92% efficiency at VIN = 48V and 300 Watts out, P(diss) is 24 Watts.

Heat Sink Usage

The UHP-28.2/12-D48 converter is primarily intended for baseplate and enclosure mount installations. However, if you prefer to attach the converter’s baseplate to an extruded aluminum heatsink in a traditional fan-forced airflow installation, the user must carefully compute the thermal resistance of the heat sink versus the power dissipation versus the ambient temperature and airflow over the heatsink. As with the passive mounting surface installations, the baseplate temperature should never exceed +110°C.