



Features

- Low cost!
- +4.75V to +5.5V input
- +2.5V (±25mV), 12 Amp output
- 200kHz, synchronous-rectifier topology
- High efficiency, 87%
- Low output noise, 40mVp-p
- Quick transient response, 30µsec
- -40 to +50°C operation with no derating
- Highly reliable, 100% SMT construction
- Remote on/off control
- Output short-circuit protection
- 1" x 2" metal package; EMC compliant
- IEC950/EN60950/UL1950 pending
- Modifications and customs for OEM's

OBSOLETE PRODUCT

Last time buy: 3 March 2014

Click here for more information.

As a result of the high efficiency, the converter has a low power loss and low heat generation. The converter is designed to be used in a wide range of applications, such as power supplies for industrial equipment, medical equipment, and consumer electronics.

Murata's UNR Series DC/DC converter delivers a full 12 Amps at an impressive 87% efficiency. Packaged in a 1" x 2" x 0.44" metal case, the converter exploits synchronous rectification, planar magnetics and 100% automatic SMT assembly to bring you an incomparable 30 Watts of 2.5V power.

The UNR-2.5/12-D5 delivers full power over the -40 to +50°C temperature range without heat sinking or forced-air cooling. It is fully line (±0.1%) and load (±0.5%) regulated and features low noise (40mVp-p) and quick (30µsec) transient response. The unit offers remote on/off control, and it can withstand a sustained output short circuit with full recovery to rated accuracy.

Designing your own 2.5V step-down buck regulator may be practical for low-power applications. When you need 12 Amps, the task becomes significantly more time consuming. Consider that the high efficiency, ease-of-use, and overall cost effectiveness of Murata Power Solutions' new 2.5V UNR Series make the quick solution the best solution.

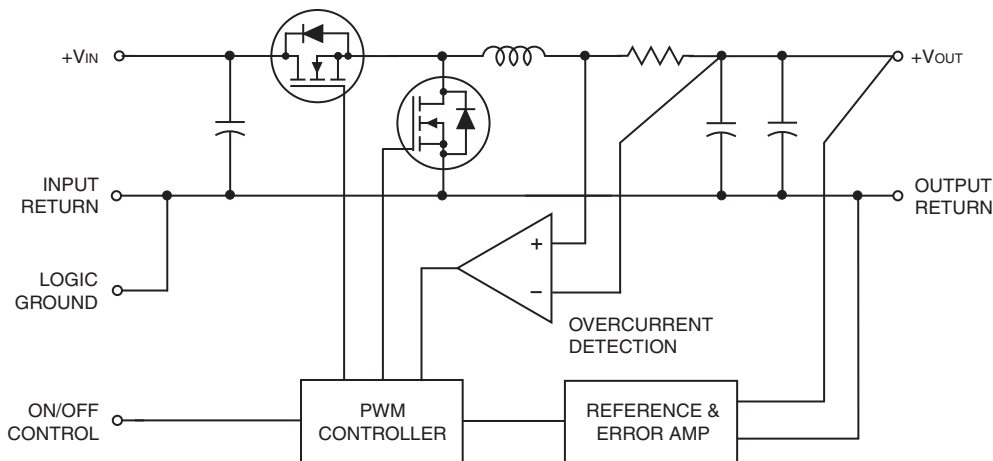

Signals applied to the On/Off Control are referenced to Logic Ground which is internally connected to Input/Output Return. The Logic Ground pin is not designed to carry heavy current. Do not install units with the Return pins open or connected via high-impedance runs.

Figure 1. Simplified Schematic



For full details go to
www.murata-ps.com/rohs

Performance/Functional Specifications

Typical @ T_A = +25°C under nominal line voltage and full-load conditions unless noted. ① ②

Input	
Input Voltage Range	4.75-5.5 Volts (5V nominal)
Input Current ③	0.15/6.9 Amps
Input Filter Type	Capacitive
Overvoltage Protection	None
Reverse-Polarity Protection	None
On/Off Control (Pin 2) ④	TTL high (or open) = on, low = off
Output	
V _{out} Accuracy (50% load)	±1% (±25mV) maximum
Temperature Coefficient	±0.02% per °C
Ripple/Noise (20MHz BW) ⑤	40mVp-p typical, 80mVp-p maximum
Line/Load Regulation	±0.1% maximum/±0.5% maximum
Efficiency	87% typical, 84% minimum
Overcurrent Detection Point ⑥	Auto-recovery
Dynamic Characteristics	
Transient Response (50% load step)	30µsec to ±1% of final value
Switching Frequency	200kHz (±20kHz)
Environmental	
Operating Temperature (Ambient):	
Without Derating	-40 to +50°C
With Derating	to +100°C (Straight line to 0 Watts)
Storage Temperature	-40 to +105°C
Physical	
Dimensions	2" x 1" x 0.44" (51 x 25 x 11.2mm)
Shielding	5-sided
Case Connection	Pin 5 (Input Return)
Case Material	Corrosion resistant steel with non-conductive, epoxy-based, black enamel finish and plastic baseplate
Pin Material	Tin over copper alloy
Weight	1.6 ounces (45.4 grams)

- ① These devices have no minimum load requirements and will regulate under no-load conditions.
- ② Achieving specified performance requires the installation of an external 470µF input capacitor with an ESR of 20mΩ and an rms ripple current rating of 6 Amps, as well as an external 22µF output capacitor with an ESR of 200mΩ or less.
- ③ No-load/full-load conditions. When the unit is off, the input "standby" current is typically 10mA.
- ④ See On/Off Control Functionality.
- ⑤ Output noise may be reduced by installing additional external capacitors across the output terminals. Caps should be selected for low ESR (typically 60mW) and located as close to the unit as possible.
- ⑥ Overcurrent detection initiates at approximately 30% above rated load, where the output current "hiccups" at an average current of 1A and remains there until the short is removed.

Absolute Maximum Ratings	
Input Voltage	7 Volts
Output Current	Current limited. Devices can withstand a sustained output short circuit without damage.
Storage Temperature	-40 to +105°C
Lead Temperature (soldering, 10 sec.)	+300°C

These are stress ratings. Exposure of devices to any of these conditions may adversely affect long-term reliability. Proper operation under conditions other than those listed in the Performance/Functional Specifications Table is not implied.

On/Off Control Functionality

The On/Off Control pin has an internal 5kΩ pull-up resistor to +V_{IN}. It can be driven with any logic circuit capable of meeting the following drive requirements. Logic "0" = 0 to +0.8V. Logic "1" = +2.0V to +V_{IN}. I_H (@V_{IN} = +2.0V) = -0.7mA. I_L (@V_{IN} = 0V) = -1.1mA. Open collector logic or a single NPN drive transistor can be used. The drive circuit should be rated for more than 5.5V. Applying a voltage to pin 2 when no input power is applied to the converter can cause permanent damage to the converter.

MECHANICAL SPECIFICATIONS

Case C5B

METAL CASE
INSULATED BASE
PINS 1-2: 0.040 ±0.002 (1.016 ±0.051)
PINS 3-6: 0.062 ±0.002 (1.575 ±0.051)

BOTTOM VIEW

DIMENSIONS ARE IN INCHES (MM)

I/O Connections	
Pin	Function P9
1	Logic Ground
2	On/Off Control
3	+Output
4	Output Return
5	Input Return
6	+Input

Note:
The case is connected to pin 5 (Input Return).

ORDERING INFORMATION

UNR-2.5/12-D5 Non-Isolated, 5V-to-2.5V, 30 Watt, DC/DC Converter, non-RoHS.



Features

- Low cost!
- +4.75V to +5.5V input
- +3.3V (±33mV), 12 Amp output
- 200kHz, synchronous-rectifier topology
- High efficiency, 90%
- Low output noise, 40mVp-p
- Quick transient response, 30µsec
- -40 to +50°C operation with no derating
- Highly reliable, 100% SMT construction
- Remote on/off control
- Output short-circuit protection
- 1" x 2" metal package; EMC compliant
- IEC950/EN60950/UL1950 pending
- Modifications and customs for OEM'st

As 3.3V CPU's, DSP's and PLD's proliferate and low-voltage currents increase, the shortcomings of both traditional centralized power architectures and the recently introduced 3.3V outputs on AC/DC converters become more apparent. The solution is to locally derive 3.3V power from buses of higher voltage (5V, 12V, 48V, etc.). "Point-of-use" power processing is the only way to guarantee the tight accuracy, low noise, and quick transient response required by these new devices.

If you are designing power-hungry 3.3V partitions or boards, consider Murata Power Solutions' new UNR-3.3/12-D5. These non-isolated, 5V-to-3.3V DC/DC's deliver up to 12 Amps. Packaged in 1" x 2" x 0.44" metal cases, these converters use synchronous rectification, planar magnetics, and 100% automatic SMT assembly to bring you the most cost-effective 3.3V power.

The 90% efficient UNR-3.3/12-D5 delivers its full 40W output power from -40 to +50°C without heat sinking or forced-air cooling. It is fully line (±0.1% max.) and load (±0.5% max.) regulated and features a TTL-compatible on/off control. These devices can withstand a sustained output short circuit and automatically recover to rated accuracy.

Designing your own 3.3V step-down buck regulator may be practical for low-power applications. When you need 12 Amps, the task becomes significantly more challenging and time consuming. It's time to consider the high efficiency, ease-of-use, and overall cost effectiveness of Murata Power Solutions' UNR Series. Safety agency approvals and full EMI characterizations are currently in progress.

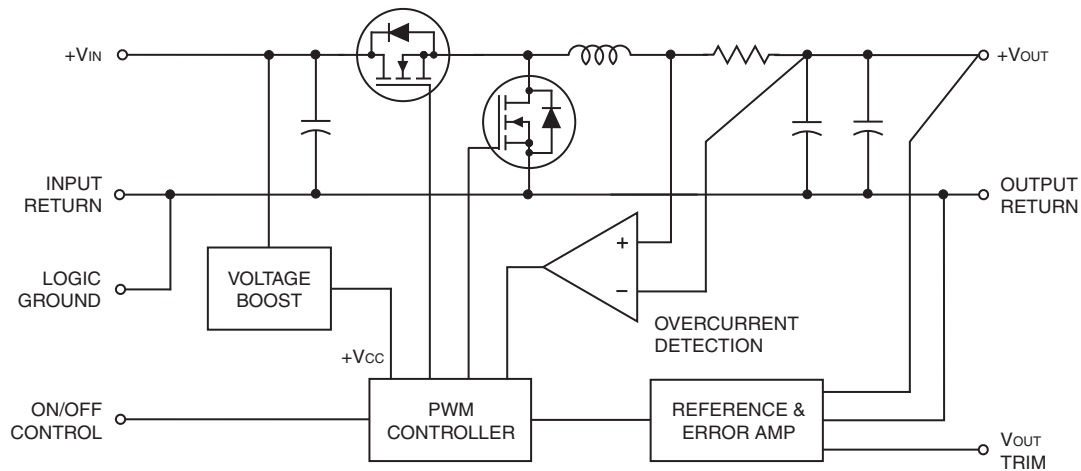

Signals applied to the On/Off Control are referenced to Logic Ground which is internally connected to Input/Output Return. The Logic Ground pin is not designed to carry heavy current. Do not install units with the Return pins open or connected via high-impedance runs.

Figure 2. Simplified Schematic

Performance/Functional Specifications

Typical @ TA = +25°C under nominal line voltage and full-load conditions unless noted. ① ②

Input	
Input Voltage Range	4.75-5.5 Volts (5V nominal)
Input Current ③	0.15/8.8 Amps
Input Filter Type	Capacitive
Overvoltage Protection	None
Reverse-Polarity Protection	None
On/Off Control (Pin 2) ④	TTL high (or open) = on, low = off
Output	
V _{OUT} Accuracy (50% load)	±1% (±33mV) maximum
Temperature Coefficient	±0.02% per °C
Ripple/Noise (20MHz BW) ⑤	40mVp-p typical, 80mVp-p maximum
Line/Load Regulation	±0.1% maximum/±0.5% maximum
Efficiency	90% typical, 87% minimum
Overcurrent Detection Point ⑥	Auto-recovery
Dynamic Characteristics	
Transient Response (50% load step)	30µsec to ±1% of final value
Switching Frequency	200kHz (±20kHz)
Environmental	
Operating Temperature (Ambient):	
Without Derating	-40 to +50°C
With Derating	to +100°C (Straight line to 0 Watts)
Storage Temperature	-40 to +105°C
Physical	
Dimensions	2" x 1" x 0.44" (51 x 25 x 11.2mm)
Shielding	5-sided
Case Connection	Pin 5 (Input Return)
Case Material	Corrosion resistant steel with non-conductive, epoxy-based, black enamel finish and plastic baseplate
Pin Material	RoHS: Gold-plate over copper alloy Non-RoHS: Tin over copper alloy
Weight	1.6 ounces (45.4 grams)

- ① These devices have no minimum load requirements and will regulate under no-load conditions.
- ② Achieving specified performance requires the installation of an external 470µF input capacitor with an ESR of 20mΩ and an rms ripple current rating of 6 Amps, as well as an external 22µF output capacitor with an ESR of 200mΩ or less.
- ③ No-load/full-load conditions. When the unit is off, the input "standby" current is typically 10mA.
- ④ See On/Off Control Functionality.
- ⑤ Output noise may be reduced by installing additional external capacitors across the output terminals. Caps should be selected for low ESR (typically 60mΩ) and located as close to the unit as possible.
- ⑥ Overcurrent detection initiates at approximately 30% above rated load, where the output current "hiccupps" at an average current of 1A and remains there until the short is removed.

Absolute Maximum Ratings	
Input Voltage	7 Volts
Output Current	Current limited. Devices can withstand a sustained output short circuit without damage.
Storage Temperature	-40 to +105°C
Lead Temperature (soldering, 10 sec.)	+300°C

These are stress ratings. Exposure of devices to any of these conditions may adversely affect long-term reliability. Proper operation under conditions other than those listed in the Performance/Functional Specifications Table is not implied.

On/Off Control Functionality

The On/Off Control pin has an internal 5kΩ pull-up resistor to +V_{IN}. It can be driven with any logic circuit capable of meeting the following drive requirements. Logic "0" = 0 to +0.8V. Logic "1" = +2.0V to +V_{IN}. I_{IH} (@V_{IN} = +2.0V) = -0.7mA. I_{IL} (@V_{IN} = 0V) = -1.1mA. Open collector logic or a single NPN drive transistor can be used. The drive circuit should be rated for more than 5.5V. Applying a voltage to pin 2 when no input power is applied to the converter can cause permanent damage to the converter.

MECHANICAL SPECIFICATIONS

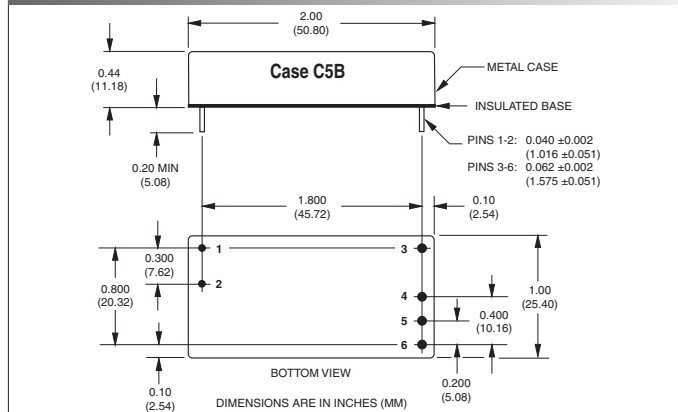

I/O Connections	
Pin	Function P9
1	Logic Ground
2	On/Off Control
3	+Output
4	Output Return
5	Input Return
6	+Input

Note:
The case is connected to pin 5 (Input Return).

ORDERING INFORMATION

UNR-3.3/12-D5	Non-Isolated, 5V-to-3.3V, 40 Watt, DC/DC Converter, non-RoHS version
UNR-3.3/12-D5-C	RoHS version

Murata Power Solutions, Inc.
11 Cabot Boulevard, Mansfield, MA 02048-1151 U.S.A.
ISO 9001 and 14001 REGISTERED



This product is subject to the following **operating requirements** and the **Life and Safety Critical Application Sales Policy**:
Refer to: <http://www.murata-ps.com/requirements/>

Murata Power Solutions, Inc. makes no representation that the use of its products in the circuits described herein, or the use of other technical information contained herein, will not infringe upon existing or future patent rights. The descriptions contained herein do not imply the granting of licenses to make, use, or sell equipment constructed in accordance therewith. Specifications are subject to change without notice. © 2013 Murata Power Solutions, Inc.