

Improved Output Filtering

Objective

To give recommendations on how to decrease the analogue output signal noise, prior to an A/D conversion in a final application. This document is relevant for VTI's SCA61T, SCA100T, SCA103T, SCA1000, and SCA1020 series inclination and acceleration sensors.

Description

In the above products there is an internal A/D converter running constantly, causing fast interference voltage spikes on analogue output(s). These glitches occur with an interval of 50 - 70µs, and last about 1 µs. They don't usually interfere with the normal analogue output signal. However, when the output is sampled very rapidly for A/D conversion, there is a risk that the voltage drops can be seen at the output, causing errors in the measurement information.

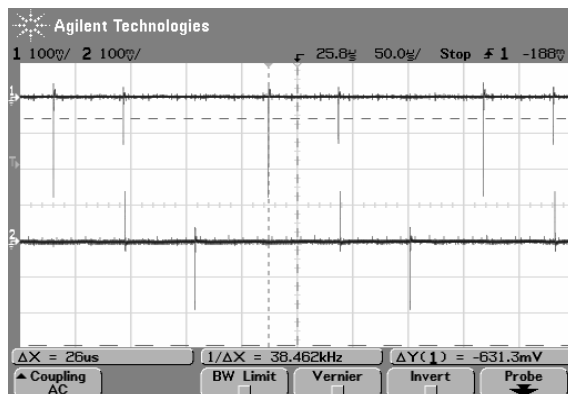

Figure 1. Oscilloscope picture of non-filtered output(s)

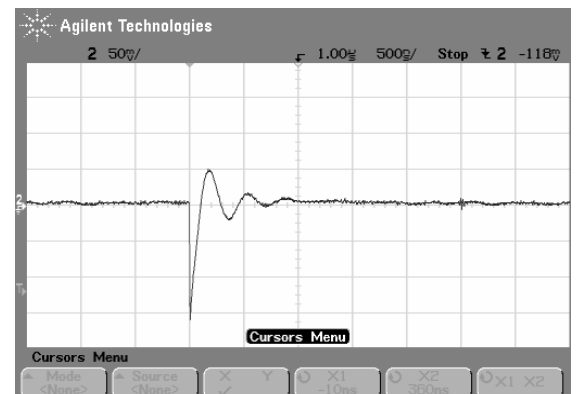

Figure 2. Oscilloscope picture of a glitch on the non-filtered output.

Solution

The interference effect of A/D conversion can be easily filtered out with a simple RC Low Pass filter (LPF) from the analogue output(s). The -3 dB frequency point of the filter is given by the equation:

$$f_{-3dB} = \frac{1}{2 * \pi * R * C}$$

where R and C are the resistance and capacitance values of the resistor and the capacitor that create the filter (see Figure 3).

When deciding what values to use for R and C, it is important to remember that the maximum allowed load capacitance for the mentioned products is 20 nF. Also when using high values of R,

remember that you are creating a voltage divider with the measurement equipment input impedance.

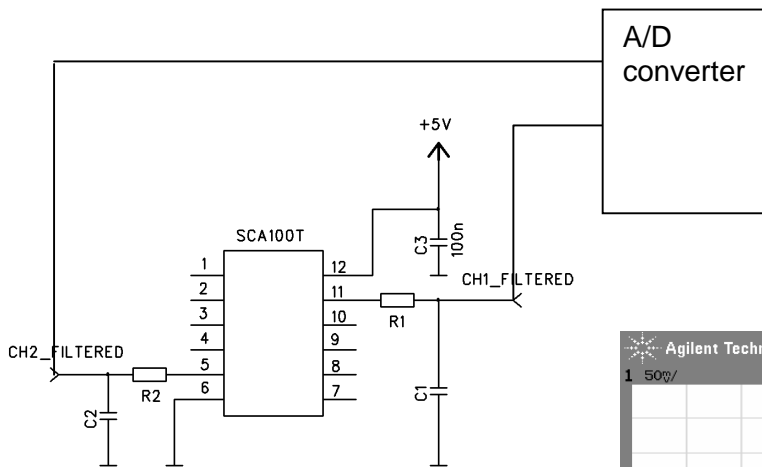

Figure 3. SCA100T with RC low pass filtering R1, C1, R2 and C2. The filter is included in the example connection in the Data-Sheet of SCA103T.

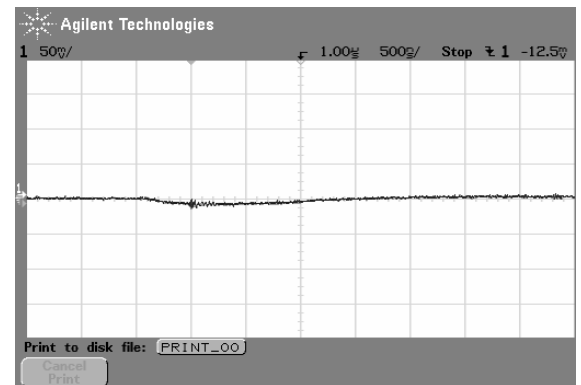

Figure 4. Oscilloscope picture of the filtered output during the glitch. R = 5 kΩ and C = 10 nF, $f_{-3dB} = 3.18$ kHz

Results

A typical result of the filtered analogue output signal can be seen in Figure 4. Corner frequency is set approximately to 3kHz, with C = 10nF and R = 5kΩ. Variation of the output signal has reduced from 200mVp-p to less than 10mVp-p.

See also TN5 for instructions of supply voltage filtering.

Document Change Control

Version	Date	Change Description
1.0	05.09.2005	First release

VTI Technologies reserves all rights to modify this document without prior notice.