

PRODUCT OVERVIEW

The PQU-COVER is a cover kit intended for use with the [PQU650](#) series of open frame products for system deployments in a semi open environment and not mounted in a totally enclosed system case (where the product is inaccessible to End Users). It is manufactured from high quality steel finished with an anti-corrosion coating. The construction also provides an optimized airflow pattern to accommodate both forced and convection cooling deployments; refer to relevant product datasheet for additional details.

The PQU-COVER kit is sold separately and it is intended that the End User assembles the cover to the open frame product directly.

ORDERING GUIDE

Model Number	Description
PQU-COVER	Cover kit for PQU650 series

MODEL USAGE TABLE

PQU650 Screwed Connector Variants	PQU650 Pluggable Connector Variants
PQU650-12	N/A
PQU650-24	PQU650-24P
PQU650-28	PQU650-28P
PQU650-48	PQU650-48P
PQU650-54	PQU650-54P



NB: Image shows use with screwed terminal connector variants i.e. PQU650-xx; however the cover is also suitable for use with the pluggable connector variants i.e. PQU650-xxP

FEATURES:

- Allows installation in equipment that does not afford protection
- ITE and Medical Safety Certification not impacted
- Refer to [ACAN-106](#): PQU650 Thermal deployment application note
- Allow operation in convection and forced cooled applications
- Painted power coat steel; corrosion resistant
- RoHS2 Complaint

MATERIALS PARTS LIST

(See View Opposite)

- ① Cover
- ② Cover retaining screws (4 pieces)
M3 x 6, thread forming screw; pozidrive flathead. Zinc plated steel

Related Application Notes

- [ACAN-106](#): PQU650 Thermal deployment application note

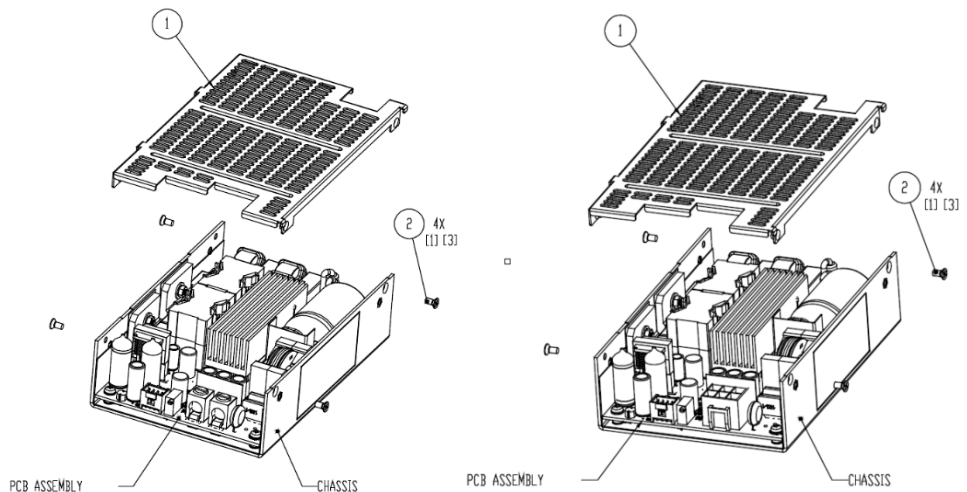

PQU650-xx Variants

PQU650-xxP Variants

INSTALLATION INSTRUCTIONS

1. The PQU-COVER kit includes the cover and 4x retaining screws in an overall poly bag. There is no additional insulation required as the clearances (from the cover to primary referenced components) is adequate to meet the requirements of both the ITE and Medical safety certification standards.
2. Install the cover (item ①) to the chassis taking care to orientate the cover to align with the relevant connectors and retention "tab" holes within the chassis side wall.
3. The retaining "tabs" are intended to accept the thread forming screw.
4. Secure the cover (item ①) to the chassis base with the 4x M3 x 6 thread forming screws (item ②).
5. Tighten the screws to a torque of 4-6 in-lb. to ensure retention (do not over tighten).



For full details go to
www.murata-ps.com/rohs

Murata Power Solutions Inc.
129 Flanders Road, Westborough, Ma 01581 USA
ISO 9001 REGISTERED



This product is subject to the following operating requirements and the Life and Safety Critical Application Sales Policy. Refer to: <https://www.murata-ps.com/requirements/>

Murata Power Solutions, Inc. ("Murata") makes no representation that the use of its products in the circuits described herein, or the use of other technical information contained herein, will not infringe upon existing or future patent rights. The descriptions contained herein do not imply the granting of licenses to make, use, or sell equipment constructed in accordance therewith. Buyer represents and agrees that it has all the necessary expertise to create and implement safeguards that anticipate dangerous consequences of failures, monitor failures and their consequences lessen the likelihood of failures that might cause harm, and take appropriate remedial actions. Buyer will fully indemnify Murata, its affiliated companies, and its representatives against any damages arising out of the use of any Murata products in safety-critical applications. Specifications are subject to change without notice.

© 2023 Murata Power Solutions, Inc.