

1. Scope

This document is applied to a magnetic sensor operating to ON/OFF when the sensor detects the magnetic field.

2. Part number

2-1 Part description Magnetic Sensor
 2-2 Murata part number MRUS74SD-001

3. Dimensions and schematics

3-1 Dimensions

3-1-1 Package outline drawing

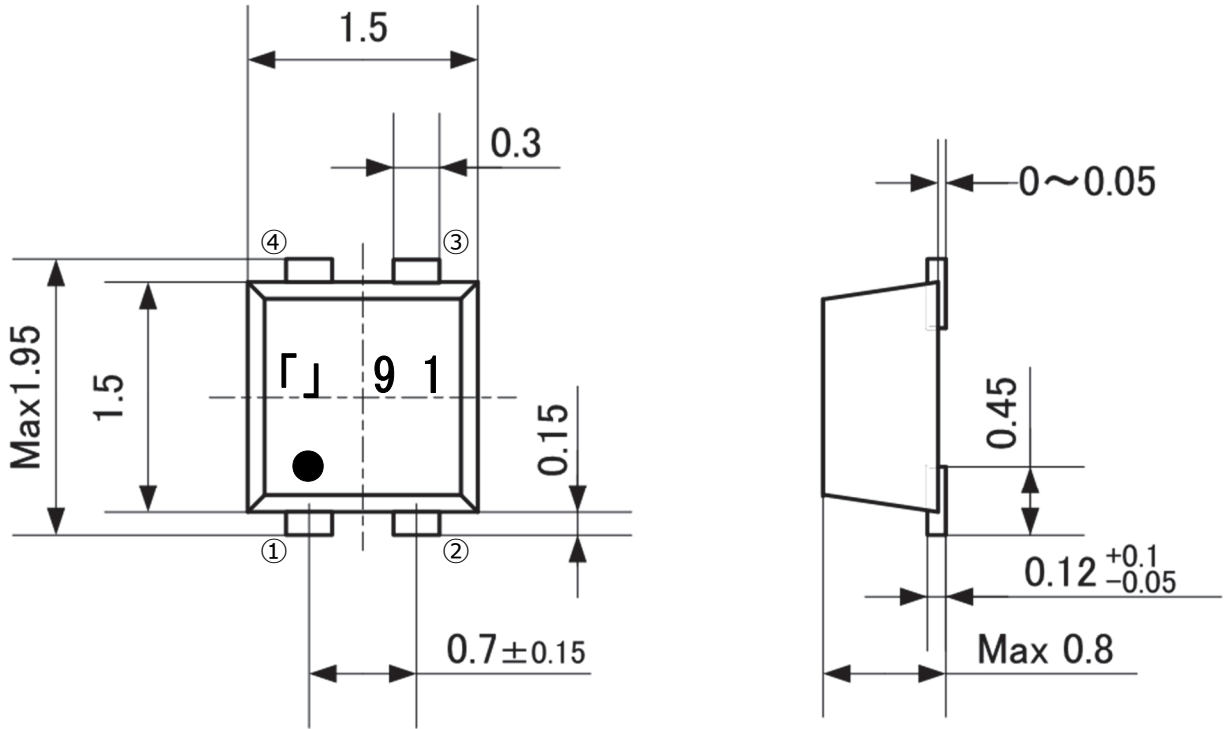

① : GND ② : Enable ③ : NC ④ : OUT

3-1-2 Marking example

(E.g.) 「」 9 1 I Control code.
 ↓ ↓ ↓ II Manufactured year...The last digit of the year
 I II III III Manufactured month..
 Jan to Sep : 1 to 9
 Oct to Dec : X, Y, Z

3-1-3 Reference mount pad

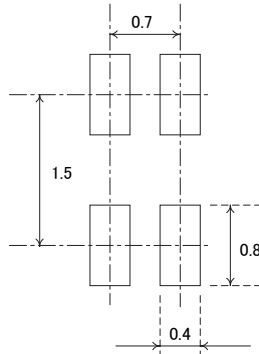

NOTE1) Please evaluate your soldering paset condition and reflow condition with our product being mounted to your product.

NOTE2) Please make sure the sensing direction of the sensor (see the item 3-2) and your magnetic field direction to the sensor.

3-2 Magnetic field application direction

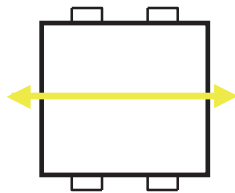

Sensing direction
(N or S)

3-3 Block wiring diagram

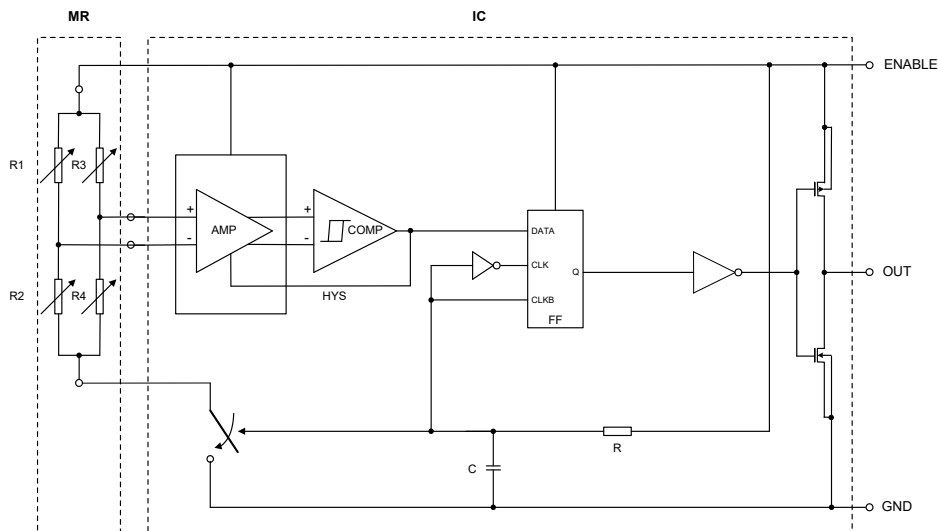

3-4 Example of enable control by microcomputer

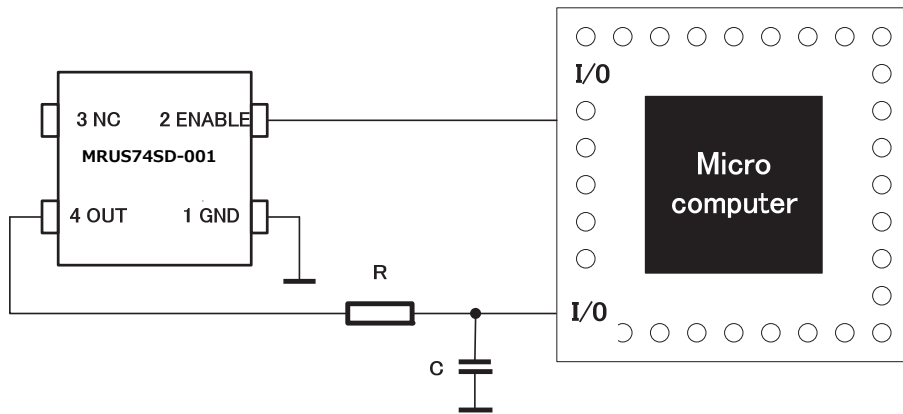

- NOTE1) Do not connect a DC power supply to the ENABLE/GND terminal (=Do not continuously energize long time with V_{IH}). The sensor operating voltage V_{IH} should be intermittently controlled by a microcomputer.
- NOTE2) Do not place a bypass capacitor between the ENABLE and GND terminals. The bypass capacitor may delay the rise of the Enable waveform and the sensor may not operate properly.
- NOTE3) The load resistance and capacitor of the OUT terminal vary depending on the microcomputer. Select one that does not affect the operation of the microcomputer. Please select it that is not affect the operation of the microcomputer.

3-5 Timing diagram

Applied magnetic field vs. output voltage

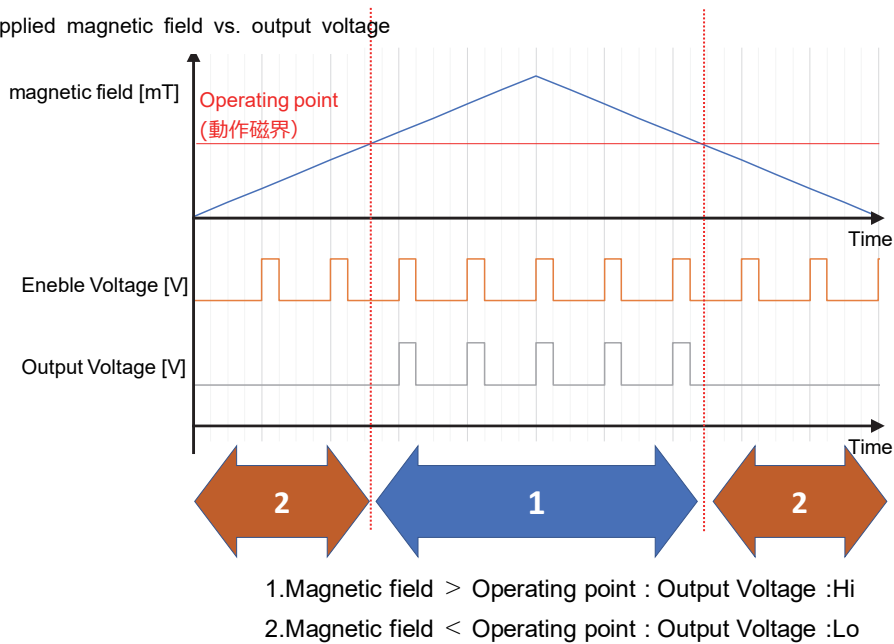

Enable voltage vs. current consumption

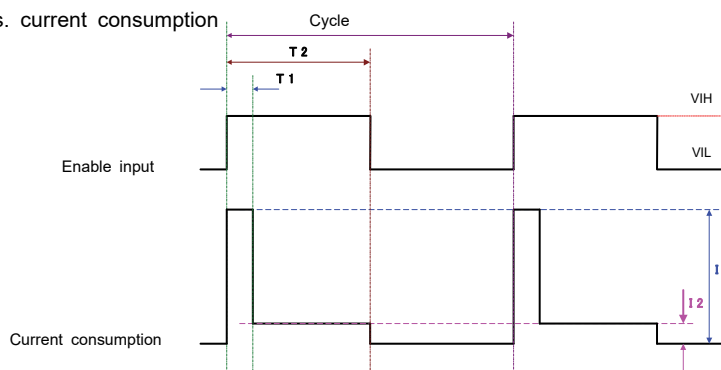

3-6 Electric characteristics/absolute maximum rating (Ta=+25±3°C)

| | Parameter | Symbol | Conditions | Min. | Typ. | Max. | Unit |
|----|--------------------------------------|-----------------|--|------|------|------|------|
| 1 | Enable voltage | V _{CC} | — | 2.0 | 3.0 | 3.6 | V |
| 2 | Enable pulse boost time (10-90%) | Tr | — | — | — | 500 | ns |
| 3 | Enable status current consumption | I1 | V _{CC} =3.0V No Load Resistance | — | 2.6 | 3.6 | mA |
| 4 | Enable pulse frequency | F | — | — | 10 | 30 | kHz |
| 5 | Enable pulse width | — | — | 3 | 30 | — | us |
| 6 | Operating magnetic field | Hon | V _{CC} =3.0V No Load Resistance | 1.0 | 1.5 | 2.0 | mT |
| 7 | Hi level output | V _{OH} | V _{CC} =3.0V No Load Resistance | 2.7 | — | — | V |
| 8 | Lo level output | V _{OL} | | — | — | 0.6 | V |
| 9 | Operating temp. range | — | — | -40 | — | +85 | °C |
| 10 | Storage temp. range | — | — | -40 | — | +125 | °C |
| 11 | Power supply voltage absolute rating | — | — | — | — | 6.0 | V |

NOTE1) Each specification is defined by testing above items individually.

NOTE2) When shifting the sensor output from L to H, please make sure the magnetic field applied to the sensor becomes higher than the above operating magnetic field (Hon) through your designing.

NOTE3) Sensitivity selection of this product is performed at V_{CC}=3.0V. Operating magnetic field can possibly change when applying the supply voltage other than 3.0V.

Reference) Average current consumption based on simulation data

Condition: Enable VIH=3.0V, VIL=0V, Ta=25°C

T1, I1, I2 determined by MR sensor: T1=1.5 μs, I1=2.6mA, I2=360 μA

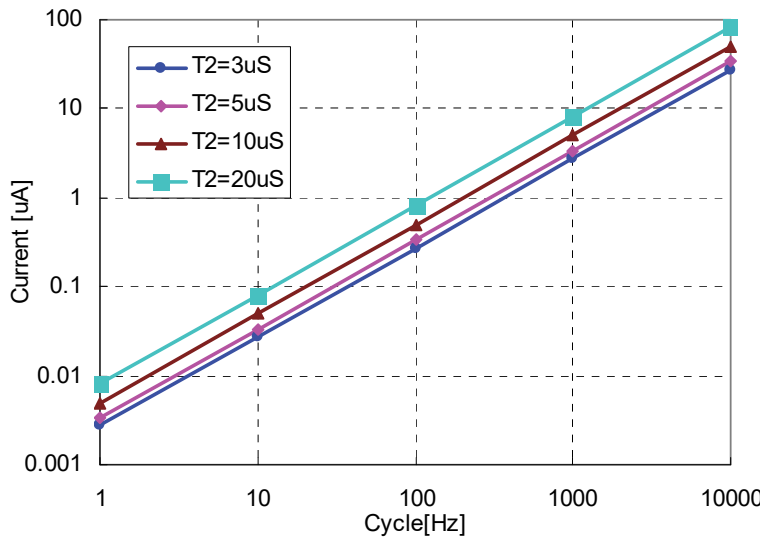

Reference) Output current-output voltage relationship

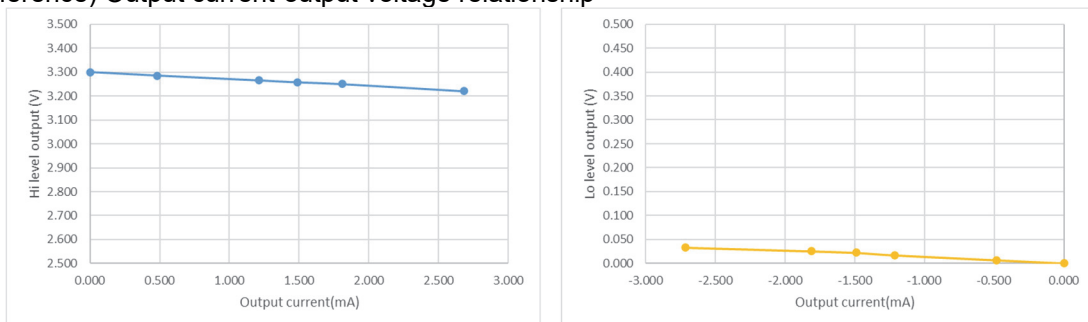

4. Packing information

4-1 Packing information

| | | |
|-----------------|----------------|--------------|
| Form of packing | Reel dimension | Pcs per reel |
| Tape & reel | φ180 | 3000pcs |

4-2 Taping specifications

4-2-1 Taping dimensions

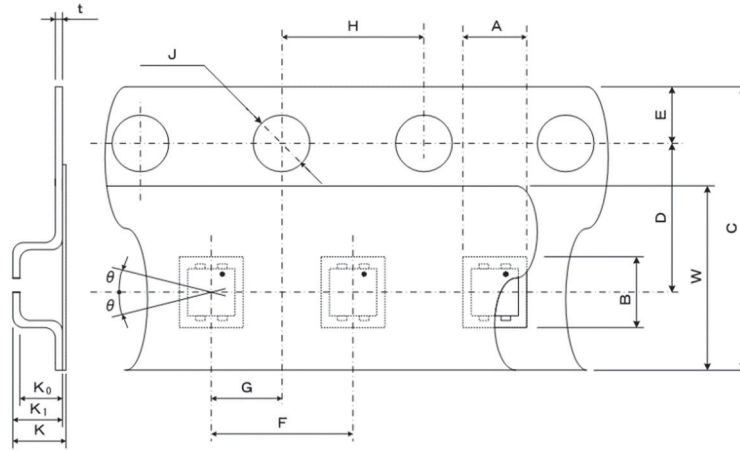

Unit:mm

| Parameter | | Symbol | Size/ Angle | Parameter | | Symbol | Size/ Angle |
|-------------------|----------|----------------|-----------------------------------|-------------------------------|-------------|----------------|----------------------------------|
| Pocket | Length | A | 1.75±0.05 | Dist. Between center lines | L direction | G | 2.0±0.05 |
| | Width | B | 2.00±0.05 | | W direction | D | 3.5±0.05 |
| | Depth | K ₀ | 0.85±0.05 | Cover tape | Width | W | 5.5 ^{+0.3} ₀ |
| | Pitch | F | 4.0±0.1 | | Width | C | 8.0±0.2 |
| Feed hole | Diameter | J | φ1.5 ^{+0.1} ₀ | Carrier tape | Thickness | T | 0.2±0.05 |
| | Pitch | H | 4.0±0.1 | | Depth | K ₁ | 1.05±0.1 |
| | Position | E | 1.75±0.1 | Device | Tilt | θ | 30°MAX |
| Overall thickness | | K | 1.03±0.1 | | | | |

4-2-2 Reel dimensions...EIAJ PRV08B compliant

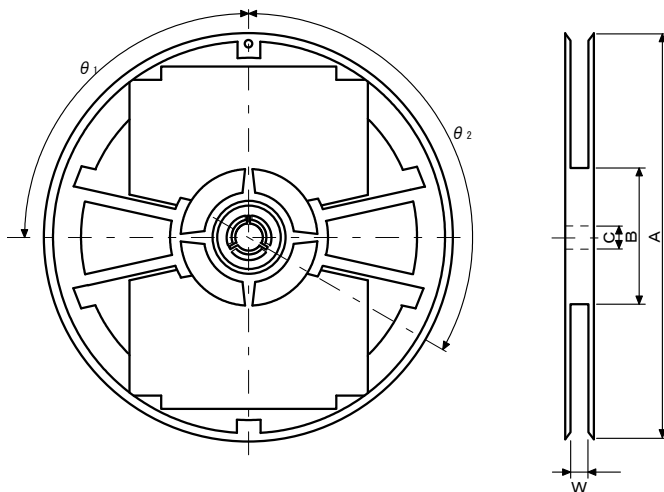

Unit: mm

| Item | Symbol | Dim/Angle |
|----------------------|-------------------------------|-----------|
| Diameter | A | φ178±2 |
| Dis. between flanges | W | 9±0.5 |
| Diameter | B | φ60±1 |
| Hub slit position | θ ₁ | 90° |
| Spindle hole diam. | C | φ13±0.5 |
| Key slit position | θ ₂ | 120° |
| Marking | Labeled on one side of flange | |

4-2-3 Start/End of taping



Reel label A (example)

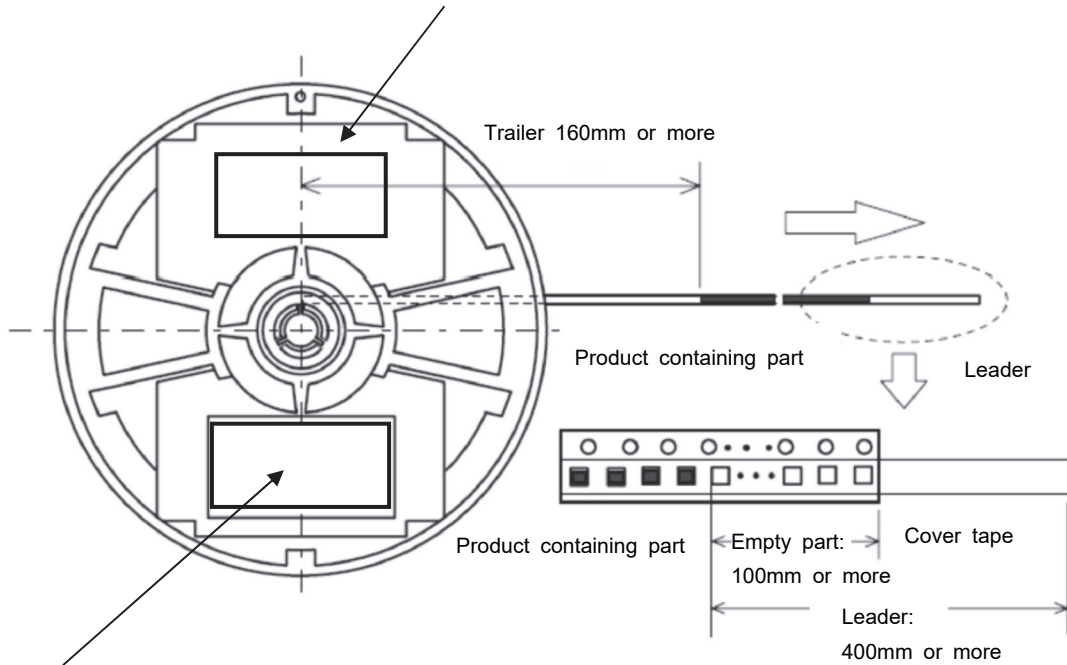

Reel label B (example)



4-2-4 Other notes

Continuously missing device shall not exceed 2 pcs.

Peeling strength of the cover tape: 0.1 to 0.7N.

4-3 Outer packing specifications

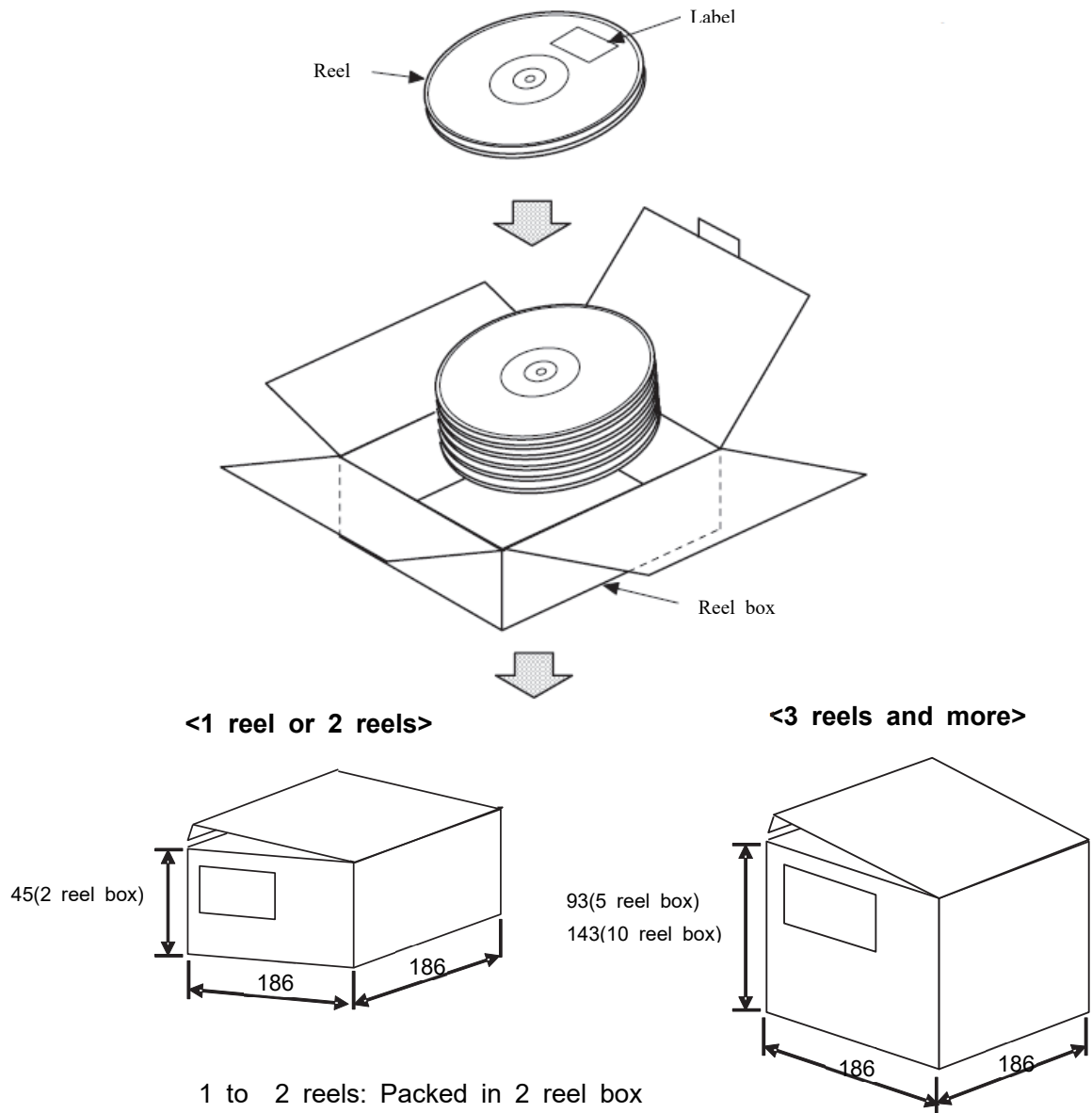

- 1 to 2 reels: Packed in 2 reel box
- 3 to 5 reels: Packed in 5 reel box
- 6 to 10 reels: Packed in 10 reel box

*When the box is not filled with reels, antistatic buffer material will be used to avoid product from moving inside box.

*Unit: mm, Tolerance: +/- 5mm

Material

Reel packing box: Cardboard

5. Mounting condition

5-1 Reflow condition

- Below is the maximum reflow condition for the product mounting.
- The temperature mentioned in below table and figure is package surface temperature.
- The absolute maximum package peak temperature is 260 °C and time within the temperature of 260 °C must not exceed 10 seconds (Requirement).

| Profile Feature | Condition |
|--|---|
| Pre-heating Temperature Min. Temperature Max. Time from Temperature Min. to Max. | 150 °C 180 °C 60-120 seconds |
| Heating Liquidous temperature Time maintained above Liquidous temperature Peak package surface temperature Time at peak surface temperature | 230°C 30 seconds max. 260°C 10 seconds max |
| Reflow times | 3 times max. |

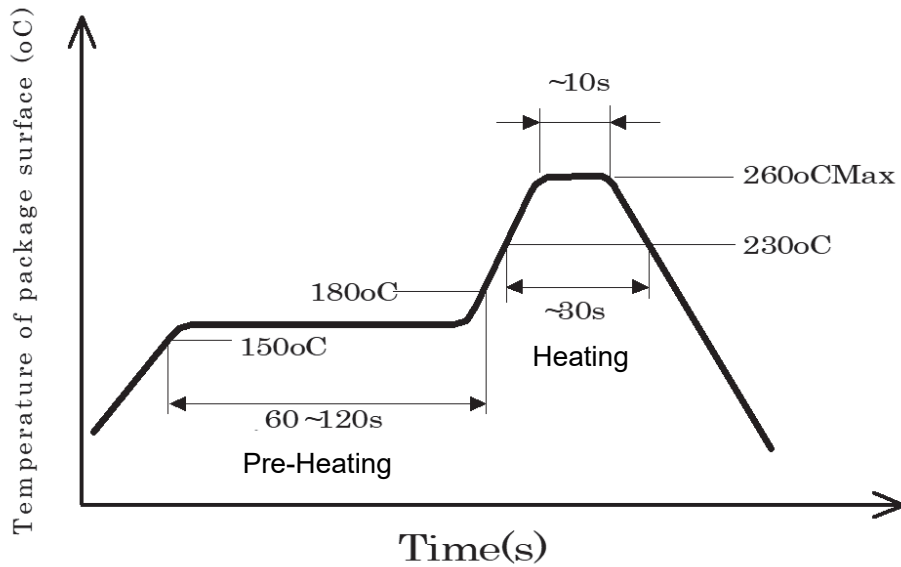

*Recommendable Print Circuit Board : Glass epoxy PCB (FR-4) , t=1.6um

6. Reliability test

| No. | Reliability test | Test conditions | Judgment criteria |
|-----|-------------------------------|---|--|
| 1 | High temp. storage | +125°C 500h No-load | <p>It shall be tested after being kept in a room over 2hours and Vcc=3.0V.</p> <p>• Output voltage Hi:2.7V or above Lo:0.6V or less</p> <p>90% and more terminal surface covered with solder</p> <p>No external abnormality found.</p> <p>No terminal fracture, loosening found.</p> |
| 2 | Low temp. storage | -40°C 500h No-load | |
| 3 | High temp, high humidity load | +85°C 85%RH 500h Load voltage 3.0V | |
| 4 | Thermal shock | -55 °C /30 min ⇔ +125 °C /30min (vapor phase) 500 cycle, no-load | |
| 5 | Vibration | Apply vibration [Max amplitude: 1.5mm, frequency: 10 to 55Hz, 1 cycle minute, 3 directions, 2h in each direction (total 6h)] | |
| 6 | Shock test | Unpacked condition, X, Y, Z direction, 1470m/s ² , 5 times/each | |
| 7 | Drop test | 100g dummy load, Height: 150cm, on the concrete, 6 sides, 10 times/each | |
| 8 | Solder heat resistance | Pretreatment: +85°C, 85%RH, 168h Reflow condition: Max. 260°C & 230°C, 30 sec, times of reflow: 3 | |
| 9 | Electrostatic resistance | Machine Model Condition: 200pF, Resistance: 0Ω, +/-200V | |
| | | Human Body Model Condition: 100pF, Resistance: 1.5kΩ, +/-2kV | |
| 10 | Solder ability | Solder temp.: +230°C, Time: 3 sec immersion | |
| 11 | Electrode sticking tendency | 5N(510gf), 4 directions, 10 sec | |
| 12 | Bending cycle | Glass epoxy PCB, t=1.6, Speed: 5mm/min, 90mm span, bending range ±1mm, 1500 cycle | |
| 13 | Bending limit | Glass epoxy PCB, t=1.6, 90mm span, bending range ±7mm. | |

7. CAUTION

7-1 Limitation of Applications

Please avoid using this product for the applications listed below which require especially high reliability in order to prevent defects that might directly cause damage to the third party's life, body, or property.

When this product is used for the applications listed below, we shall not be liable for any claims on the product.

- ① Aircraft equipment
- ② Aerospace equipment
- ③ Undersea equipment
- ④ Generating plant equipment
- ⑤ Medical equipment
- ⑥ Transportation equipment (vehicles, trains, ships, etc.)
- ⑦ Traffic signal equipment
- ⑧ Disaster prevention/ crime prevention equipment
- ⑨ Data processing equipment
- ⑩ Application of similar complexity and/or reliability requirements to the applications listed above.

7-2 FAIL-SAFE

Be sure to provide appropriate fail-safe function on your product to prevent a second damage that may be caused by the abnormal function or the failure of our product.

8. CAUTION FOR USE

8-1 HANDLING

- This product may be degraded by electrostatic discharge. It is necessary to take anti-static precautions when handling.
- This sensor operates with the Enable pulse of power supply. Do not connect a DC power supply to the ENABLE / GND terminal (continuous energization with VIH for a long time). Otherwise it only holds the judgment result of the first cycle detection (no reaction to the following change of magnetic field), even the sensor may be damaged.

8-2 DESIGN

- Please carefully evaluate this product for the magneto-variation of the magnet used along with this product, otherwise this product may result in the miss-operation or the non-operation.
- Sensor miss-operation or non-operation may occur due to the influence of the magnetic noise from surrounding devices such as motor. Please make sure there is no influence of the magnetic noise in designing process.
- Please be careful about a magnetic body (Iron, Nickel, etc.) and a magnetic noise immunity that may affect the magnetism of a magnet.

- Please do not supply inverse voltage or excess voltage to this product. If applied, this product may be damaged and electrically destroyed.
- Please avoid plugging/unplugging of connector cable while the power is on. Do not place the bypass capacitor on the MRUS-74SD-001.
- If the Enable pulse is ringing or if noise is superimposed, the sensor may be malfunctioning.
- Do not place bypass capacitors or inductors with levels that affect sensor operation.
- If the current supply capacity is insufficient, the sensor may malfunction. Please design the circuit with considering the current supply capacity. For example, when driving two or more sensors with one power port of the microcomputer, the current supply capacity may be insufficient.

Example (Oscilloscope waveform)

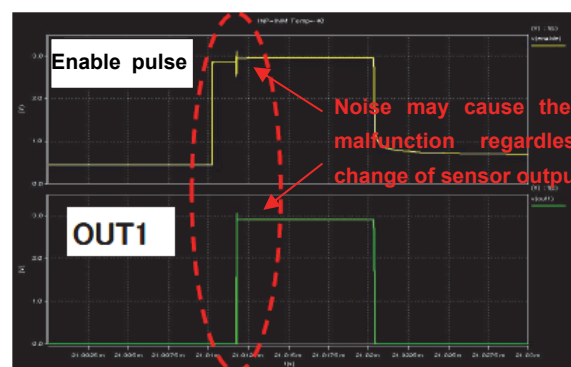
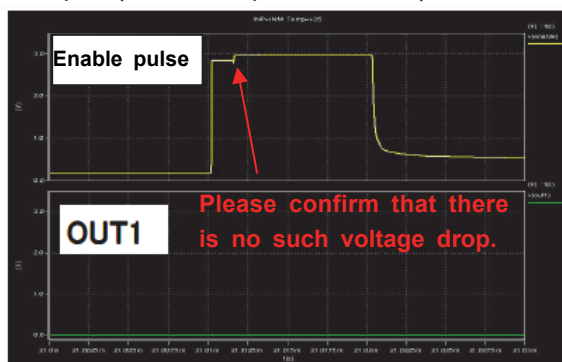

<Enable pulse waveform noise and malfunction of OUT1>

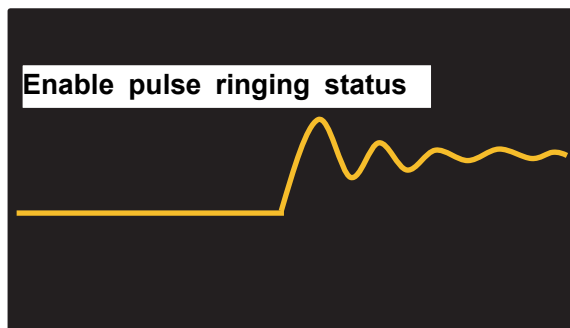

<Example of Enable pulse ringing that causes malfunction>

8-3 Storage condition

- Recommended storage conditions are listed below.
 - Temperature: +5 to +30°C
 - Humidity: 70% (RH)% and lower
- *Desiccator storage or storage in N₂ atmosphere is recommended.
- Allowable storage time of the product is one year from the date of delivery. Please take account of the storage conditions listed above. Please also use the product as soon as possible after opening the product packing to avoid the deterioration of solder ability.
- Please avoid the water, chemical solvent, or oil.
- Please avoid the corrosive gas (Cl₂ H₂S, NH₃ NO₂, NO₃ etc.)
- Please avoid the strong vibration or shock.

8-4 Mounting

- Please mount this product under standard reflow condition. Otherwise this product may be damaged.
- Hand soldering is not allowed for this product.
- Please do not apply excessive load to the terminals. Also, please do not bend the terminals.
- Please do not apply excessive bending stress to the product by bending the PCB or by similar handling as it may change the sensor sensitivity.
- Please make sure the mounting state of the sensor after mounting it. Depend on your application, mounting error may cause the sensor miss operation.

9. NOTE

- Make sure that your product has been evaluated in view of your specifications with our product being mounted to your product.
- Not to use our product deviating from the agreed specification.