

Typical unit

PRODUCT OVERVIEW

The MPQ0125V3NBMC is a highly efficient, 300W digitally controlled, isolated DC/DC converter that converts 18-75Vdc input into an isolated regulated 12Vdc output. The MPQ0125V3NBMC is fully protected from overcurrent, overtemperature, and overvoltage faults. It also provides hardware status.

PMBus™ communication features included the Black Box capability, which is packaged within the industry standard quarter-brick format.

ORDERING GUIDE

Part Number	VIN Range	VOUT Nominal	Output Power	L inch (mm)	W inch (mm)	H inch (mm)
MPQ0125V3NBMC (with PMBus)	18-75Vdc	12Vdc	300W	2.3 (58.4)	1.45 (36.8)	0.57 (14.4)
MPQ0125V3NBC (without PMBus)	18-75Vdc	12Vdc	300W	2.3 (58.4)	1.45 (36.8)	0.57 (14.4)

FEATURES

- DC input 18-75V (48V nominal)
- DC output 12V (nominal)
- Output Trim & Sense
- Power Good
- Baseplate for Optimized Thermal Performance
- High Efficiency up to 94%
- Over-current, Over-temperature, and Over-voltage protection
- PMBus™ 1.2 Interface



SAFETY FEATURES

- UL 62368-1 2nd Ed, 2014-12-01 (Audio/video, information and communication technology equipment) Part 1: Safety requirements
- CAN/CSA-C22.2 No. 62368-1-14 (Audio/video, information and communication technology equipment) Part 1: Safety requirements
- CE Mark and UKCA Mark
- 2250Vdc Basic Insulation (Input-to-Output)
- RoHS Compliant

ABSOLUTE MAXIMUM RATING

Parameter	Notes	Min.	Nom.	Max.	Units
Input Voltage		-0.5	-	80	Vdc
On/off Pin Voltage		0	-	15	Vdc
Other Pin Voltage		-0.3	-	3.6	Vdc
Operating Ambient Temperature		-40	-	85	°C
Storage Ambient Temperature		-55	-	125	°C
Isolation Voltage		-	-	2250	Vdc

INPUT CHARACTERISTICS, Ta= 25°C, Vin=48V, Nominal Vout, unless otherwise specified

Parameter	Conditions	Min.	Nom.	Max.	Units
Vin Operating Range	Steady State	18	48	75	Vdc
Voltage Transients	100ms duration	-	-	100	
Start-up Voltage		15.5	-	18.5	
Lockout Hysteresis Voltage		0.2	-	3.0	
Overvoltage Shutdown Recovery		74	-	78	
Turn-On/Turn-Off Hysteresis		0.2	-	3.0	
Full Load Conditions	Vin @ nominal	-	6.6	-	A dc
Low Line Input Current	Vin @ minimum	17	-	20	
Inrush Current	Vin @ nominal	-	0.7	1.0	A ² ·Sec
No Load Input Current	Vin @ nominal, Iout = 0 A, Unit = ON	-	-	500	mA
Shut-Down Mode Input Current	Off, UV, OT	-	-	100	
Input Capacitance	Nichicon UPM1 J470MPH or equivalent	220	-	-	µF

OUTPUT CHARACTERISTICS, Ta= 25°C, Vin=48V, Nominal Vout, unless otherwise specified

Parameter	Conditions	Min.	Nom.	Max.	Units
Output Voltage Range	With Trim Adjustment	9.60	12.0	13.20	Vdc
Output Current		0	-	25	A
Output Power		0	-	300	W
Ripple & Noise	20MHz Bandwidth	-	-	150	mVp-p
Efficiency	Vin = 24V, full load	-	94	-	%
	Vin = 48V, full load	-	93.5	-	
	Vin = 60V, full load	-	93	-	
Switching Frequency	Variable Switching Control	50	-	300	kHz



For full details please visit our website:
www.murata-ps.com/rohs



Murata Power Solutions
GENERAL AND SAFETY

Parameter	Notes	Min.	Typ.	Max.	Units
Turn-On Delay-1:		30	-	60	ms
Defined as time between Vin reaching Turn-On voltage and Vout reaching 10% of final value. Enable is asserted before Vin reaches Turn-On voltage					
Turn-On Delay-2:		0	-	15	ms
Defined as time between Enable and Vout reaching 10% of final value.					
Output Voltage Rise time:		30	-	60	ms
Defined as time between Vout at 10% of final value and Vout at 90% of final value.					
ISOLATION					
Input to Output Test Voltage		-	-	2250	Vdc
Input to Baseplate Test Voltage		-	-	1500	
Baseplate to Output Test Voltage		-	-	1500	
Arc Sense Level	Based on DOC#62506. Currently the arc sense test set level 5, 12mA	-	Level 5	-	
Insulation Safety Rating		-	Basic	-	
Isolation Resistance		-	10	-	Mohm
Isolation Capacitance		-	1500	-	pF
Safety Approvals	Designed to meet UL/CSA/IEC 62368-1				
Calculated MTBF		-	5000	-	kHours

¹Inrush Current is defined as the peak current drawn by the unit when unit is enabled after Vin is present. Iin is defined as the steady-state operating current when unit is operating at Vin Max and Pout Max. While Vout is rising, Pout is ≤25% of Pout Max with a resistive load

OUTPUT VOLTAGE CHARACTERISTICS, Ta= 25°C, Vout Nominal Load, unless otherwise specified

Output	Notes	Min.	Typ.	Max.	Units
Output Voltage	Initial Output Voltage (VIN = 48 V, Iout = 0 A, temp = 25 °C)	11.97	12.00	12.03	Vdc
	Under all Line, Load and Temperature Conditions	11.76	12.00	12.24	
	Output Adjust Range (Hardware TRIM)	9.60	12.00	13.20	
Line Regulation	Vin = 18-75V, Vout = nominal, full load	-20	-	20	mV
Load Regulation	Iout = min. to max., Vin = 48V, I Vout@min_load-out@max_load	-20	-	20	mV
Trim Down	Trim (pin #6) to -Vout Sense (pin #5), Rt down (kΩ) = 5.11/(Vnom-Vo)/Vnom-10.22	-20	-	-	%
Trim Up	Trim (pin #6) to +Vout Sense (pin #7), Rt up(kΩ) = 5.11*Vnom*(1+Δ)/(1.225*Δ)-5.11/Δ-10.22 Δ=(Vnom-Vo)/Vnom	-	-	10	%
Dynamic Load Response		0	-	900	μSec
Dynamic Load Peak Deviation	50-75-50%, 0.1 A/μs, within 1% of Vout (Vin = Vin_nom, tested with a 1.0 μF ceramic, 10 μF tantalum and 470 μF low ESR polymer capacitor across the load. Low ESR polymer capacitor is X-CON Electronics ULR477M1CF1ATV or equivalent)	-800	-	800	mV
Pre-Bias Voltage		0	-	Vout	Vdc
Output Power	Long-Term: 100°C Max. Baseplate maintained by system/Host; maximum 96 hours/Year, No loss of output (OTP); Short-Term: 110°C Max. Baseplate	-	-	300	W
Output Current		0	-	25	A
Minimum Load			N/A		
90% of Vnom, after warmup, Configurable via PMBus					
SHORT CIRCUIT					
Short circuit protection method			Latch off		
Ripple/Noise	1. Vin = Vin_min. to Vin_max and Io = Io_min to Io_max, tested with a 1.0 μF ceramic, 10 μF tantalum and 470 μF low ESR polymer capacitor across the load. 2. 470μF low ESR polymer capacitor is X-CON Electronics ULR477M1CF1ATV or equivalent.	-	-	150	mVpp
Output Capacitance	ULR477M1CF1ATV or equivalent.	470	-	5000	μF
Temperature Coefficient		-	0.01	0.02	% of Vnom./°C

PROTECTION CHARACTERISTICS

Parameter	Notes	Min.	Nom.	Max.	Units
Vin Undervoltage Shutdown		14.5	-	17.5	Vdc
Vin Overvoltage Shutdown ¹		75.5	-	79.5	
Vout Overvoltage Shutdown		-	13.7	-	
Output Over-Current		26	-	34	A
Over-Temperature (baseplate hotspot)		-	120	-	°C

¹ OVP event either latch unit off (reset by cycling V_{in} or Enable pin), or will automatically restart when OV condition is removed.

ENVIRONMENTAL CHARACTERISTICS

Parameter	Notes	Min.	Nom.	Max.	Units
Operating Ambient Temperature Range		-40	-	85	°C
Storage Temperature		-55	-	125	°C
Altitude, Operating		-500	-	13,120	feet
Relative Humidity, Operating, Non-Condensing		10	-	90	%
Relative Humidity, Non-Operating, Non-Condensing		10	-	95	%
EMI					
Conducted (FCC part 15, EN55022)	With external filter		Class A		

PMBus READ ACCURACY

Parameter	Notes	Min.	Nom.	Max.	Units
VIN_READ:		-1.5	-	1.5	Vdc
VOUT_READ:		-2	-	2	%
IOUT_READ:(Vin=48V, Io=5% ~ 50% of Iout)		-3	-	3	A
IOUT_READ:(Vin=48V, Io=50% ~ 100% of Iout)		-5	-	5	%
TEMP_READ:		-10	-	10	°C

Remote On/Off Control¹

Parameter	Notes	Min.	Nom.	Max.	Units
"N" suffix (Negative Logic):					
Enable Pin Off Voltage Levels ²		3.5	-	13.5	Vdc
Enable Pin On Voltage Levels ²		-0.1	-	0.8	
Enable Pin Current (into pin, ext. pull-up to 10V)		-	0.1	0.2	mA
"P" suffix (Positive Logic):					
Enable Pin Off Voltage Levels ²		0	-	0.8	Vdc
Enable Pin On Voltage Levels ²		3.5	-	13.5	
Enable Pin Current (into pin, ext. pull-up to 10V)		-	0.1	0.2	mA
Remote Sense Compliance		-	-	10	%

¹ On/Off can be configured by PMBus command 0xDD (MFR_ENABLE_POLARITY_CONFIG); Default configuration does not ignore the control pin and therefore requires the On/Off to be asserted to start the unit.

² Enable signal is referenced to Vin(-).

POWER-GOOD SIGNAL¹

Parameter	Notes	Min.	Nom.	Max.	Units
Output Voltage Low (trigger limits)		-	8.4	-	Vdc
Output Voltage High (trigger limits)		-	10.2	-	
Output Voltage Hysteresis		0.2	-	-	
High State Voltage		3	-	5.5	Vdc
High State Leakage Current (into Pin)		0	-	10	µA
Low State Voltage		0	-	0.8	Vdc
Low State Current (into Pin)		0	-	5	mA
Power Good Signal De-assert Response Time		0	-	3	ms
Power Good Signal Assert Response Time		0	-	3	ms
OverTemp Warning		10°C below OTP threshold			°C

¹The module provides Power Good (PG) flag in the STATUS_WORD register that indicates the output voltage is within a specified tolerance of its target level and no fault condition exists. The Power Good pin default logic is positive, and it can be configured by MFR_PGOOD_POLARITY.

MECHANICAL DIMENSIONS

Parameter	Notes	Min.	Nom.	Max.	Units
Outline Dimensions (with baseplate)		2.3 x 1.45 x 0.57			Inches
		58.4 x 36.8 x 14.4			mm
Weight (unit)		2.82			Ounces
		80			grams
Pin Length		0.180			Inches
		4.57			mm
Through Hole Pin Diameter		0.040/0.060			Inches
		1.016/1.524			mm
Digital Interface Pin Diameter		0.028			Inches
		0.7			mm
TH Pin Plating Metal and Thickness (Nickel subplate)		1	2	3	µm
TH Pin Plating Metal and Thickness (Tin overplate)		5	6.5	8	µm
Baseplate Material		Black Anodized Aluminum			

ELECTRICAL CHARACTERISTICS CURVES (Ta=25°C)

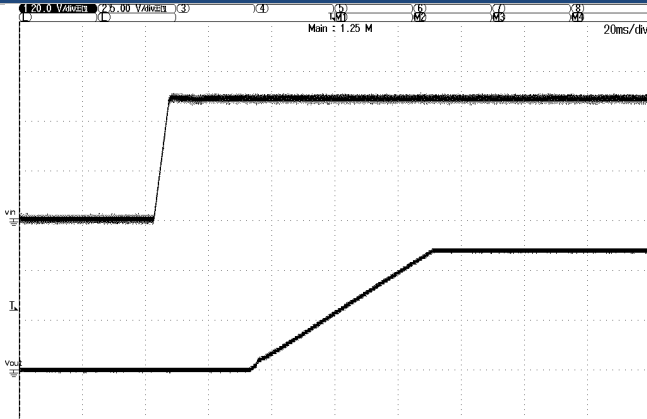

Figure 2 Vin ON
 48Vin, 25A Load, 470µF min cap load

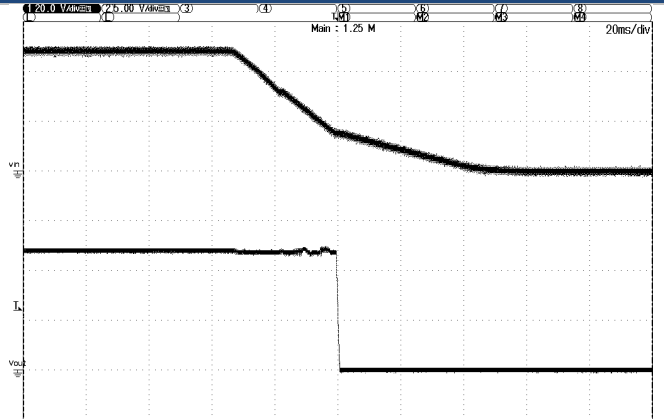

Figure 3 Vin Off
 48Vin, 25A Load, 470µF min cap load

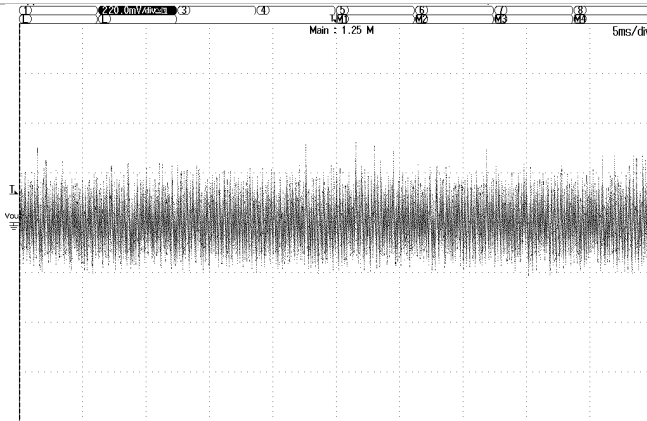

Figure 4 Ripple & Noise
 48Vin, 25A Load, 470µF min cap load

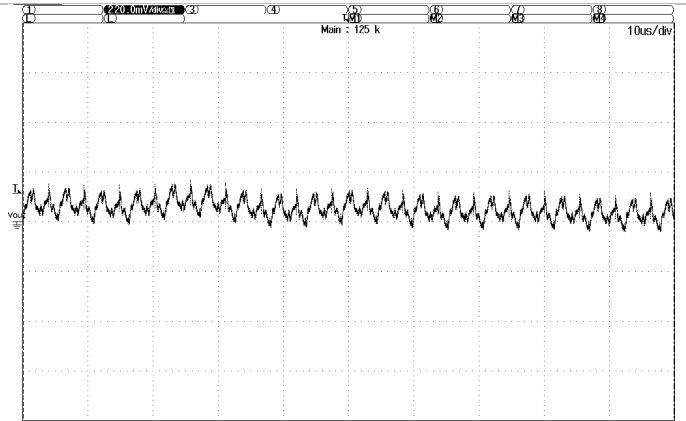

Figure 5 Ripple & Noise
 48Vin, 25A Load, 470µF min cap load

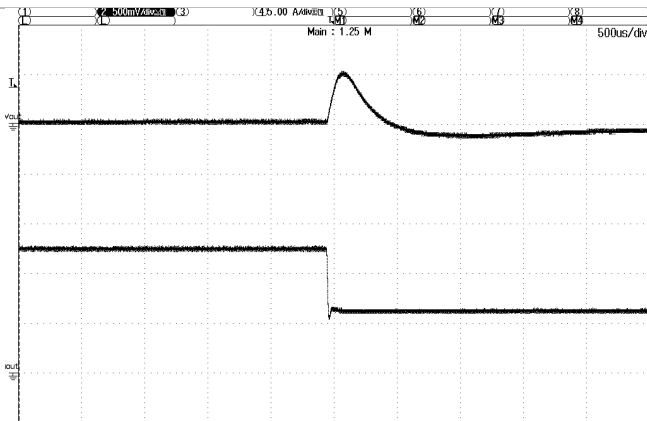

Figure 6 Output Transient Response
 48Vin, 75%-50% Load, 470µF min cap load

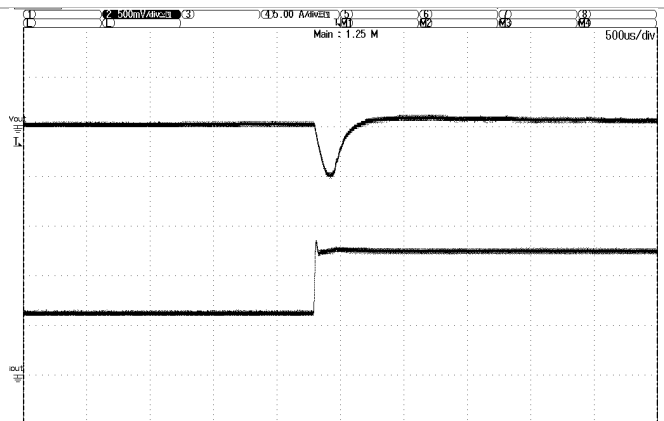

Figure 7 Output Transient Response
 48Vin, 50%-75% Load, 470µF min cap load

(Continued)
ELECTRICAL CHARACTERISTICS CURVES (Ta=25°C)

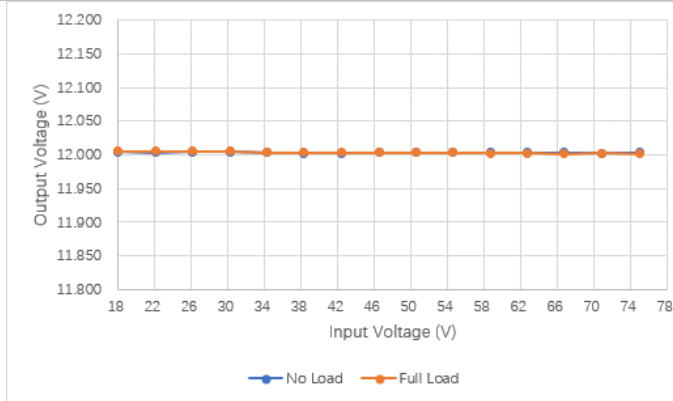

Figure 8 Output Voltage vs Input Voltage

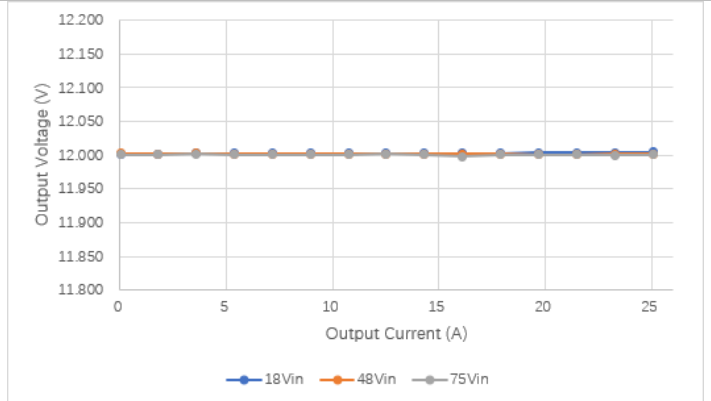

Figure 9 Output Voltage vs Output Current

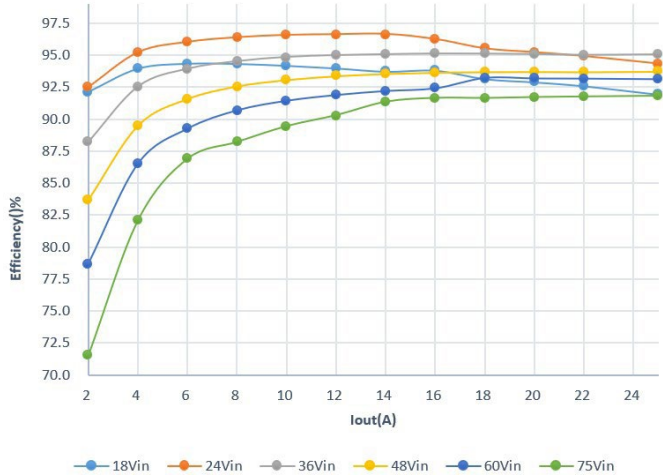

Figure 10 Efficiency Vs. Line Voltage & Load Current @ 25°C

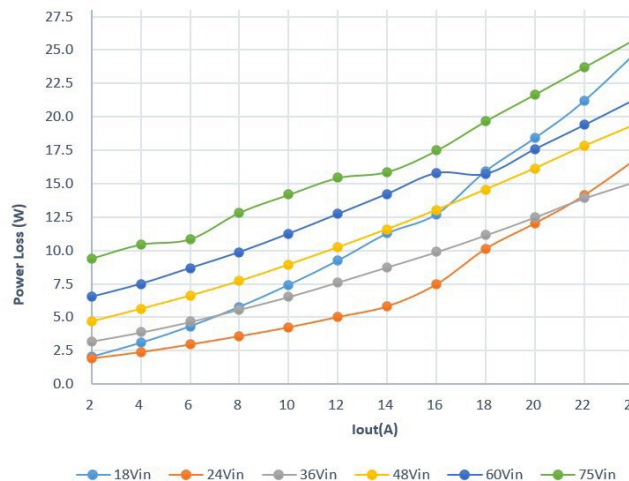

Figure 11 Power Dissipation Vs. Load Current @ 25°C

THERMAL DERATING

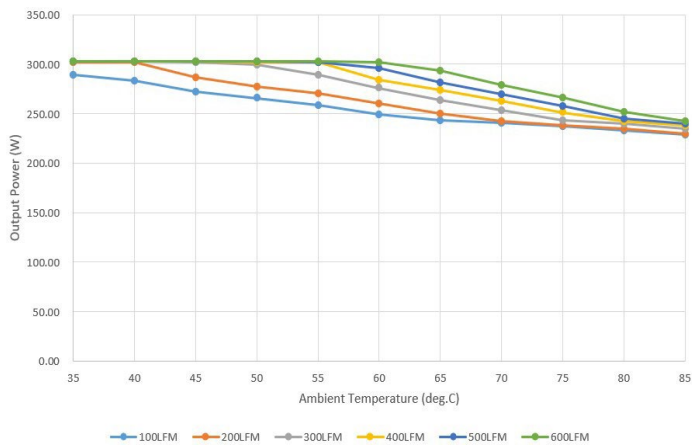

Figure 12 Temperature Derating – Longitudinal Direction
Vin=24Vdc (airflow is from Vin to Vout on 10"x10" PCB, with baseplate)

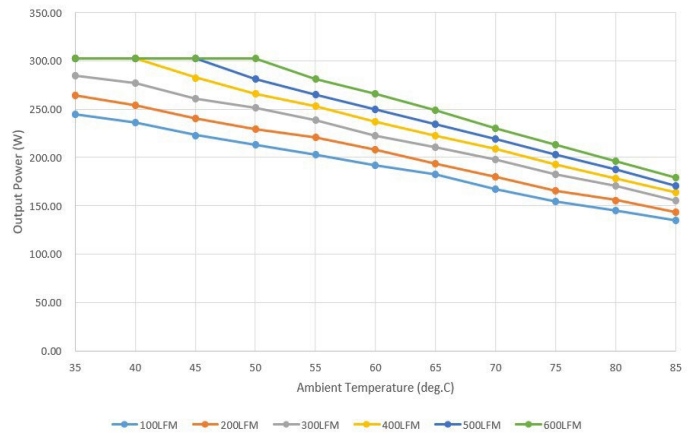

Figure 13 Temperature Derating – Longitudinal Direction
Vin=48Vdc (airflow is from Vin to Vout on 10"x10" PCB, with baseplate)

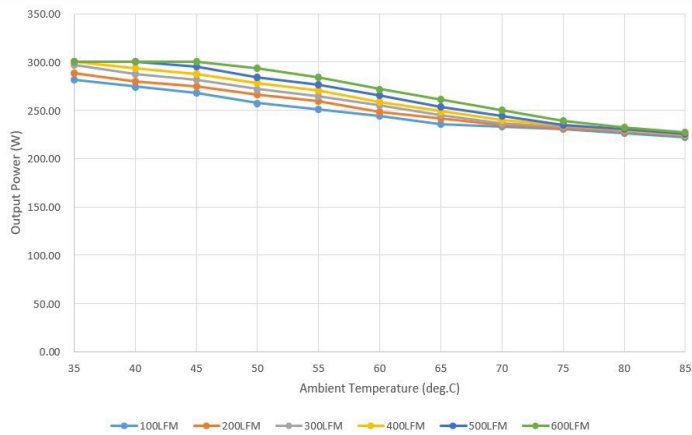

Figure 14 Temperature Derating – Longitudinal Direction
Vin=24Vdc (airflow is from Vin to Vout on 10"x10" PCB, without baseplate)

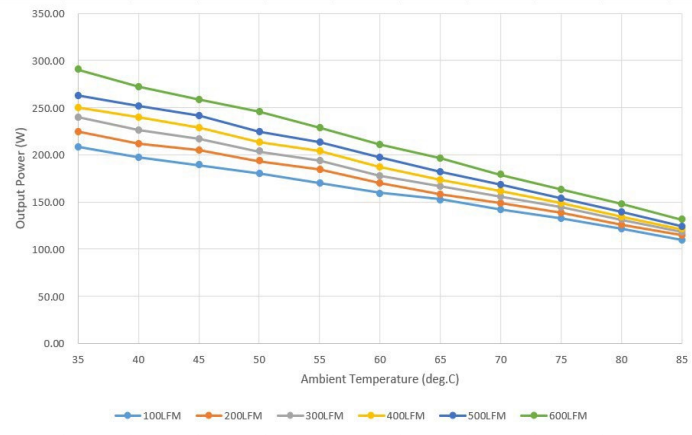
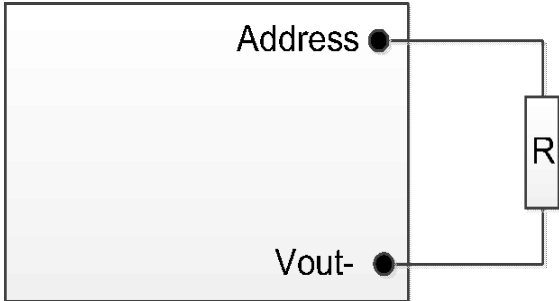

Figure 15 Temperature Derating – Longitudinal Direction
Vin=48Vdc (airflow is from Vin to Vout on 10"x10" PCB, without baseplate)

STATUS AND CONTROL SIGNALS

Signal Name	I/O	Description	Interface Details																														
Address	Input	<p>The Module has flexible PMBus addressing capability. By connecting different resistors from Address pin to GND pin, 14 possible addresses can be acquired. The 7 Bit PMBUS address is defined by the value of the resistor as shown in the table below, and +/-1% resistor accuracy is acceptable. If there is any resistance exceeding the requested range, default address 126 will be returned.</p>  <p>PMBUS address is selected by applying an external resistor from the Address to Vout (-) as defined in table blow.</p> <table border="1"> <thead> <tr> <th>PMBus Address</th> <th>Resistor Value (Kohm)</th> </tr> </thead> <tbody> <tr><td>96</td><td>10</td></tr> <tr><td>97</td><td>15</td></tr> <tr><td>98</td><td>21</td></tr> <tr><td>99</td><td>28</td></tr> <tr><td>100</td><td>35.7</td></tr> <tr><td>101</td><td>45.3</td></tr> <tr><td>102</td><td>56.2</td></tr> <tr><td>103</td><td>69.8</td></tr> <tr><td>104</td><td>88.7</td></tr> <tr><td>105</td><td>107</td></tr> <tr><td>106</td><td>130</td></tr> <tr><td>107</td><td>158</td></tr> <tr><td>108</td><td>191</td></tr> <tr><td>109</td><td>232</td></tr> </tbody> </table> <p>+/-1% resistor accuracy is acceptable</p>	PMBus Address	Resistor Value (Kohm)	96	10	97	15	98	21	99	28	100	35.7	101	45.3	102	56.2	103	69.8	104	88.7	105	107	106	130	107	158	108	191	109	232	DC voltage between the limits of 0 and +3.3Vdc.
		PMBus Address	Resistor Value (Kohm)																														
96	10																																
97	15																																
98	21																																
99	28																																
100	35.7																																
101	45.3																																
102	56.2																																
103	69.8																																
104	88.7																																
105	107																																
106	130																																
107	158																																
108	191																																
109	232																																
Clock	Input	<p>A serial clock line compatible with PMBus™ Power Systems Management Protocol Part 1 – General Requirements Rev 1.2. No additional internal capacitance is added that would affect the speed of the bus. The signal is provided with a series isolator device to disconnect the internal power supply bus in the event that the power module is unpowered.</p>	<p>VIL is 0.8V maximum VOL is 0.4V maximum when sinking 3mA VIH is 2.1V minimum</p>																														
Data	Both	<p>A serial data line compatible with PMBus™ Power Systems Management Protocol Part 1 – General Requirements Rev 1.2. The signal is provided with a series isolator device to disconnect the internal power supply bus, if the power module is unpowered.</p>	<p>VIL is 0.8V maximum VOL is 0.4V maximum when sinking 3mA VIH is 2.1V minimum</p>																														
SMBALERT#	Output	<p>Alerts the host/system, that a fault or Warning has been detected (mirrors the STATUS_x fault/warn register bits) within the module and is useful in applications requiring real time fault notification independent or in addition to reading PMBus™ STATUS_x register fault bits which may not be read by system/host frequently enough to detect that a fault/warning bit flag was set.</p> <p>Internally driven low <0.4Vdc indicates a Vout, Iout, Vin, Temperature, or Power Good fault/warning has been detected and remains low until the fault/warning stimulus has been removed and the system/host clears the individual bit flag or issues "CLEAR_FAULTS" command.</p> <p>Driven high, >2.4Vdc to indicate no fault conditions within power module are detected.</p>																															

PMBus GENERAL CHARACTERISTICS

General Specifications:

- PMBus Rev. 1.2; SMBALERT# is supported; PEC is supported; Linear data format is used.
- Unit restores the entire contents of the non-volatile user store memory when power up.
- PEC is supported.
- Max bus speed: 400kHz.
- SMBALERT# is supported.
- Linear data format used.

Signal Levels

Parameter	Min.	Nom.	Max.	Unit
Bus Speed			400	kHz
Logic High Input	2.1		3.3	Vdc
Logic Low Input	0		0.8	Vdc
Logic High Output	2.3			Vdc
Logic Low Output			0.4	Vdc

PMBus Monitoring Accuracy

Parameter	Min.	Nom.	Max.	Unit	Notes/Conditions
Vin Read	-1.5		1.5	V	
Vout_Read	-2		2	%	
Iout Read	-5		5	%	Vin=48V, Io=50% ~ 100% of Io, max;
	-3		3	A	Vin=48V, Io=5% ~ 50% of Io, max;
TEMP Read	-10		10	°C	

PMBus ADDRESSING

This power module series offers three address configurations to support a wide range of applications. The address is set by externally connecting two resistors from each of the two address pins “Addr1” and “Addr0” to signal ground “Sig_Gnd” and forms two octal (0 to 7) digits, each pin setting one digit. The resistor value for each digit is defined according to the desired configuration.

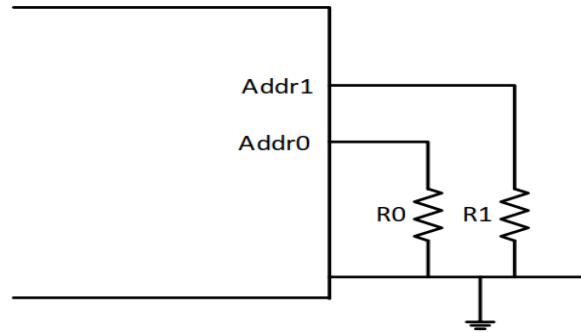

Addressing configuration 0 (default): If the calculated PMBus address is 0~12D, 40D, 44D, 45D or 55D, SA0 or SA1 lefts open, default PMBus address 127D is assigned instead.

Digit	Resistor Value R _{SA0} /R _{SA1} [kΩ]
0	10
1	15.4
2	23.7
3	36.5
4	54.9
5	84.5
6	130
7	200
Calculation: PMBus_Address = 8x (SA1 index) + (SA0 index)	

$$\text{PMBus_Address} = 8x (\text{SA1 index}) + (\text{SA0 index})$$

Addressing configuration 0 (default): If the calculated PMBus address is 0D, 11D, 12D, SA0 or SA1 lefts open, default PMBus address 119D is assigned instead.

Digit	Resistor Value R _{SA0} /R _{SA1} [kΩ]
0	10
1	22
2	33
3	47
4	68
5	100
6	150
7	220
Calculation: PMBus_Address = 8 x (SA0 value) + (SA1 value)	

$$\text{PMBus_Address} = 8x (\text{SA0 index}) + (\text{SA1 index})$$

Addressing configuration 0 (default): If the calculated PMBus address is 0~12D, 40D, 44D, 45D or 55D, SA0 or SA1 lefts open, default PMBus address 88D is assigned instead.

Digit	Resistor Value R _{SA0} /R _{SA1} [kΩ]
0	24.9
1	49.9
2	75
3	100
4	124
5	150
6	174
7	200
Calculation: PMBus_Address = 16 x Addr1 + Addr0	

$$\text{PMBus_Address} = 16x\text{Addr1} + \text{Addr0}$$

Follow these steps to change the power module address configuration:

- Select the desired address configuration via PMBus command 0xF5.
- Save configuration to non-volatile user store memory by writing command 0x15 “STORE_USER_ALL”.
- Recycle input power.

PMBus COMMANDS										
CMD	Command Name	SMBus Transaction Type: Writing Data	SMBus Transaction Type: Reading Data	Number Of Data Bytes	Default Value		Lower Limit	Upper Limit	Unit	Note
01h	OPERATION	Write Byte	Read Byte	1	0x80					Only support 0x80 and 0x00
02h	ON_OFF_CONFIG	Write Byte	Read Byte	1	0x1D					Bit7:5 Reserved Bit4 Reserved Bit3:2 1:Control pin 2:Operation 3:Control pin & Operation Bit1 Reserved Bit0 Reserved
03h	CLEAR_FAULTS	Send byte	N/A	0	N/A					
10h	WRITE_PROTECT	Write Byte	Read Byte	1	0x00					
11h	STORE_DEFAULT_ALL	N/A	N/A	0	N/A					
12h	RESTORE_DEFAULT_ALL	Send byte	N/A	0	N/A					
15h	STORE_USER_ALL	Send byte	N/A	0	N/A					
16h	RESTORE_USER_ALL	Send byte	N/A	0	N/A					
19h	CAPABILITY	N/A	Read Byte	1	0xB0					
1Ah	QUERY	N/A	"Block Write - Block Read Process Call"	1						
1Bh	SMBALERT_MASK	Write Word	"Block Write - Block Read Process Call"	2						
20h	VOUT_MODE	N/A	Read Byte	1	0x17					
21h	VOUT_COMMAND	Write Word	Read Word	2	0x1800	12	9.6	13.2	V	
22h	VOUT_TRIM	Write Word	Read Word	2	0		-2.4	1.2	V	Effective after turn off then to turn back on
35h	VIN_ON	Write Word	Read Word	2	16.75				V	
36h	VIN_OFF	Write Word	Read Word	2	15.75				V	
40h	VOUT_OV_FAULT_LIMIT	Write Word	Read Word	2	0x1C00	13.7	9.6	15.6	V	
41h	VOUT_OV_FAULT_RESPONSE	Write Byte	Read Byte	1	0x80					7:6: All support 5:3: Only support latch or continuous hiccup 2:0: Set turn off delay when 7:6=01B, unit is 130ms
42h	VOUT_OV_WARN_LIMIT	Write Word	Read Word	2	0x1B00	13.5	9.6	15.6	V	
43h	VOUT_UV_FAULT_LIMIT	Write Word	Read Word	2	0x1066	8.2	0.	15.6	V	
44h	VOUT_UV_FAULT_RESPONSE	Write Byte	Read Byte	1	0xF8					
45h	VOUT_UV_WARN_LIMIT	Write Word	Read Word	2	0x1599	10.8	0	15.6	V	
46h	IOUT_OC_FAULT_LIMIT	Write Word	Read Word	2	0xE1E0	30	26	34	A	
47h	IOUT_OC_FAULT_RESPONSE	Write Byte	Read Byte	1	0x80					7:6: 00B is continues operation without interruption, 01B/10B is not supported, 11B is supported. 5:3: Only support latch or continuous hiccup 2:0: Not supported
4Ah	IOUT_OC_WARN_LIMIT	Write Word	Read Word	2	0xE1C0	28	25	35	A	
4Fh	OT_FAULT_LIMIT	Write Word	Read Word	2	0x0078	120	30	130	°C	Default value of with "B" suffix: 120°C
50h	OT_FAULT_RESPONSE	Write Byte	Read Byte	1	0x80					7:6: 00B is continues operation without interruption, 01B is not supported (same behavior as 00B), 10B/11B are supported. 5:3: Only support latch or continuous hiccup 2:0: Not supported

51h	OT_WARN_LIMIT	Write Word	Read Word	2	0x0071	113	30	130	°C	
55h	VIN_OV_FAULT_LIMIT	Write Word	Read Word	2	0xEA6C	77.5	75.5	79.5	V	
56h	VIN_OV_FAULT_RESPONSE	Write Byte	Read Byte	1	0xF8					
57h	VIN_OV_WARN_LIMIT	Write Word	Read Word	2	0xEA60	76	75	80	V	
58h	VIN_UV_WARN_LIMIT	Write Word	Read Word	2	0xE884	16.5	14.5	17.5	V	
59h	VIN_UV_FAULT_LIMIT	Write Word	Read Word	2	0xE880	16	14.5	17.5	V	
5Ah	VIN_UV_FAULT_RESPONSE	Write Byte	Read Byte	1	0xF8					
5Eh	POWER_GOOD_ON	Write Word	Read Word	2	0x1466	10.2	1	13.2	V	
5Fh	POWER_GOOD_OFF	Write Word	Read Word	2	0x10CC	8.4	1	13.2	V	
61h	TON_RISE	Write Word	Read Word	2	0x003C	60	20	100	ms	
68h	POUT_OP_FAULT_LIMIT	Write Word	Read Word	2	0x0168	360	300	400	W	
69h	POUT_OP_FAULT_RESPONSE	Write Byte	Read Byte	2	0x80					
6Ah	POUT_OP_WARN_LIMIT	Write Word	Read Word	2	0x014A	330	300	400	W	
78h	STATUS_BYTE	Write Byte	Read Byte	1	N/A					
79h	STATUS_WORD	Write Word	Read Word	2	N/A					
7Ah	STATUS_VOUT	Write Byte	Read Byte	1	N/A					
7Bh	STATUS_IOUT	Write Byte	Read Byte	1	N/A					
7Ch	STATUS_INPUT	Write Byte	Read Byte	1	N/A					
7Dh	STATUS_TEMPERATURE	Write Byte	Read Byte	1	N/A					
7Eh	STATUS_CML	Write Byte	Read Byte	1	N/A					
88h	READ_VIN	N/A	Read Word	2	N/A				V	
8Bh	READ_VOUT	N/A	Read Word	2	N/A				V	
8Ch	READ_IOUT	N/A	Read Word	2	N/A				A	
8Dh	READ_TEMPERATURE_1	N/A	Read Word	2	N/A				°C	
94h	READ_DUTY_CYCLE	N/A	Read Word	2	N/A				%	
95h	READ_FREQUENCY	N/A	Read Word	2	N/A				kHz	
96h	READ_POUT	N/A	Read Word	2	N/A				W	
98h	PMBUS_REVISION	N/A	Read Byte	1	0x22					
99h	MFR_ID	N/A	Block Read	22	"Murata Power Solutions"					
9Ah	MFR_MODEL	Block Write*	Block Read	<=20	N/A					
9Bh	MFR_REVISION	Block Write*	Block Read	<=10	N/A					
9Ch	MFR_LOCATION	Block Write*	Block Read	<=10	N/A					
9Dh	MFR_DATE	Block Write*	Block Read	<=10	N/A					
9Eh	MFR_SERIAL	Block Write*	Block Read	<=20	N/A					
A0h	MFR_VIN_MIN	N/A	Read Word	2	0xE890	18			V	
A1h	MFR_VIN_MAX	N/A	Read Word	2	0xEA58	75			V	
A2h	MFR_IIN_MAX	N/A	Read Word	2	0xDA80	20			A	
A3h	MFR_PIN_MAX	N/A	Read Word	2	0x014F	335			W	
A4h	MFR_VOUT_MIN	N/A	Read Word	2	0x1333	9.6			V	
A5h	MFR_VOUT_MAX	N/A	Read Word	2	0x1A66	13.2			V	
A6h	MFR_IOUT_MAX	N/A	Read Word	2	0xE8C8	25			A	
A7h	MFR_POUT_MAX	N/A	Read Word	2	0x012C	300			W	
A8h	MFR_TAMBIENT_MAX	N/A	Read Word	2	0x0055	85			°C	
A9h	MFR_TAMBIENT_MIN	N/A	Read Word	2	0X078D	-40			°C	
ADh	IC_DEVICE_ID	N/A	Block Read		"TMS320F280023"					
C0h	MFR_MAX_TEMP_1	N/A	Write Word	2	0x0082	130			°C	
DAh	Erase EEPROM	Write Word	N/A	2	N/A					
DDh	MFR_ENABLE_POLARITY_CONFIG	Write Byte*	Read Byte	1	0x00					Default value of negative logic: 0x00 Default value of positive logic: 0x02
DEh	MFR_PGOOD_POLARITY	Write Byte	Read Byte	1	0x01					Default value of negative logic: 0x00 Default value of positive logic: 0x01

DFh	MFR_BLACKBOX_CONFIG_BYTE	Write Byte*	Write Byte	1	0x03					Bit0: Blackbox Enable Bit1: Rewrite Enable
E0h	MFR_BLACKBOX_EVENT	N/A	Block Read	32						
E1h	MFR_BLACKBOX_OFFSET	Write Byte*	Write Byte	1						
E8h	MFR_VIN_OV_FAULT_HYS	Write Word*	Read Word	2	0xE808	1	0.2	3	V	
E9h	MFR_VIN_UV_FAULT_HYS	Write Word*	Read Word	2	0xE808	1	0.2	3	V	
EAh	MFR_OT_FAULT_HYS	Write Word*	Read Word	2	0x000A	10	5	50	°C	
F5h	MFR_PMBUS_ADDRESS_CONFIG	Write Byte*	N/A	32	N/A					
F6h	MFR_CALIBRATION_STATUS	N/A	Read Byte	1	0x07					
F9h	MFR_VIN_SENSE_CALIBRATION	Write byte*	N/A	1	N/A					
FAh	MFR_IOUT_SENSE_CALIBRATION	Write Word*	N/A	2	N/A					
FBh	MFR_VOUT_SET_POINT_CALIBRATION	Write Word*	N/A	2	N/A					
FCh	MFR_SUPERVISOR_PASSWORD	Block Write*	N/A	N/A	N/A					

NOTES:

* Only available in supervisor mode (default state is user mode, send password to command 0xFC to change to supervisor mode).

1 Unit restores the entire contents of the non-volatile User Store memory when power up.

2 PEC is supported.

3 Max bus speed: 400kHz.

4 SMBALERT# is supported.

5 Linear data format used.

MFR COMMANDS

DAh Erase EEPROM

BITS	VALUE	ERASE MODE	MEANING
15:12	0001	The erase object is all content	Erase all Content
	0010	The erase object is block	Erase block
	0011	The erase object is page	Erase page
11:8	0000	Select block 0, or block 1 to be erased	Erase block 0
	0001		Erase block 1
:1	0000	Select the specific page from page 0 to page 15 to be erased.	Erase page 0
	0001		Erase page 1
	0010		Erase page 2

	1101		Erase page 13
	1110		Erase page 14
	1111		Erase page 15

Block 0	Block 1
Page 0	Page 0
Page 1	Page 1
Page 2	Page 2
.....
Page 13	Page 13
Page 14	Page 14
Page 15	Page 15

EEPROM data structure

DDh MFR_PRIMARY_ON_OFF_CONFIG

BITS	PURPOSE	VALUE	MEANING
7:3		00000	Reserved
2	Controls how the unit responds to the CONTROL pin	0	Unit ignores the primary ON/OFF pin
		1	Unit requires the primary ON/OFF pin to be asserted to start the unit
1	Polarity of primary ON/OFF logic	0	Active low (Pull pin low to start the unit)
		1	Active high (Pull high or open to start the unit)
0		0	Reserved

DEh MFR_PGOOD_POLARITY

BITS	PURPOSE	VALUE	MEANING
7:1		000000	Reserved
0	Power good polarity of pin 12	0	Negative logic, output low if Vout rises to specific value
		1	Positive logic, output high if Vout rises to specific value

E8h MFR_VIN_OV_FAULT_HYS

Hysteresis of VIN_OV_FAULT recover, Linear data format

E9h MFR_VIN_UV_FAULT_HYS

Hysteresis of VIN_UV_FAULT recover, Linear data format

EAh MFR_OT_FAULT_HYS

Hysteresis of OT_FAULT recover, Linear data format

F3h MFR_FAULT_STATUS

Real-time fault status

Bits	Meaning
15	VIN_OV_FAULT
14	VIN_UV_FAULT
13	RSVD
12	RSVD
11	RSVD
10	VOUT_OV_FAULT
9	VOUT_OV_FAST_FAULT
8	RSVD

Bits	Meaning
7	IOUT_OC_FAULT
6	IOUT_SHORT_FAULT
5	OUTPUT_POWER_FAULT
4	OT_FAULT
3	PRI_ENABLE_OFF
2	PMBUS_OPERATION_OFF
1	RSVD
0	MINI_OFF_TIME

F4h MFR_FAULT_COUNTER

Bits 15:0

How many faults was occurred all the time

Max counter 65535, will start over from 0 if exceeds this number

Duplicate failure will not be counted, for example: continuous hiccup will be counted as 1 time fault

F5h MFR_EVENT_LOG

F6h MFR_CALIBRATION_STATUS

Refer to calibration procedure file

F9h MFR_VIN_SENSE_CALIBRATION

Step.x	Vin calibrate point (V)	Write Byte
Step 1	17	0x01
Step 2	38	0x02
Step 3	58	0x03
Step 4	76	0x04

FAh MFR_IOUT_SENSE_CALIBRATION

Refer to calibration procedure file

FBh MFR_VOUT_SET_POINT_CALIBRATION

Refer to calibration procedure file

FCh MFR_SUPERVISOR_PASSWORD

Set unit to supervisor mode or ROM mode, Refer to password table

STATUS WORD AND BYTE

GREEN = supported
STATUS_VOUT
7 VOUT_OV_FAULT
6 VOUT_OV_WARNING
5 VOUT_UV_WARNING
4 VOUT_UV_FAULT
3 VOUT_MAX Warning
2 TON_MAX_FAULT
1 TOFF_MAX_WARNING
0 VOUT Tracking Error

STATUS_IOUT
7 IOUT_OC_FAULT
6 IOUT_OC_LV_FAULT
5 IOUT_OC_WARNING
4 IOUT_UC_FAULT
3
2 In Power Limiting Mode
1 POUT_OP_FAULT
0 POUT_OP_WARNING

STATUS_TEMPERATURE
7 OT_FAULT
6 OT_WARNING
5 UT_WARNING
4 UT_FAULT
3 Reserved
2 Reserved
1 Reserved
0 Reserved

STATUS_CML
7 Invalid/Unsupported Command
6 Invalid/Unsupported Data
5 Packet Error Check Failed
4 Memory Fault Detected
3 Processor Fault Detected
2 Reserved
1 Other Communication Fault
0 Other Memory or Logic Fault

STATUS_WORD
7 VOUT
6 IOUT/POUT
5 INPUT
4 MFR_SPECIFIC
3 POWER_GOOD#
2 FANS
1 OTHER
0 UNKNOWN
7 BUSY
6 OFF
5 VOUT_OV_FAULT
4 IOUT_OC_FAULT
3 VIN_UV_FAULT
2 TEMPERATURE
1 CML
0 NONE OF THE ABOVE

STATUS_OTHER
7 Reserved
6 Reserved
5 Input A Fuse/Breaker Fault
4 Input B Fuse/Breaker Fault
3 Input A OR-ing Device Fault
2 Input B OR-ing Device Fault
1 Output OR-ing Device Fault
0 Reserved

STATUS_INPUT
7 VIN_OV_FAULT
6 VIN_OV_WARNING
5 VIN_UV_WARNING
4 VIN_UV_FAULT
3 Unit Off For Low Input Voltage
2 IIN_OC_FAULT
1 IIN_OC_WARNING
0 PIN_OP_WARNING

STATUS_MFR_SPECIFIC
Manufacturer Defined
Manufacturer Defined
Manufacturer Defined
Manufacturer Defined
Manufacturer Defined
Manufacturer Defined
Manufacturer Defined
Manufacturer Defined
Manufacturer Defined

STATUS_FANS_1_2
7 Fan 1 Fault
6 Fan 2 Fault
5 Fan 1 Warning
4 Fan 2 Warning
3 Fan 1 Speed Override
2 Fan 2 Speed Override
1 Air Flow Fault
0 Air Flow Warning

STATUS_FANS_3_4
7 Fan 3 Fault
6 Fan 4 Fault
5 Fan 3 Warning
4 Fan 4 Warning
3 Fan 3 Speed Override
2 Fan 4 Speed Override
1 Reserved
0 Reserved

SHIPPING PACKAGING DETAILS,

ITEM NO. (95000050121)	PART NUMBER	DESCRIPTION	QTY
1	2300208	SHIPPING BOX, 10" X 10" X 2.50"	3
2	2300221	SHIPPING TRAY BASE (PAD) .75" THICK	3 (NOTE 8)
3	2300234	SHIPPING TRAY, 1/4 BRICK (15 CAVITY)	6
4	2300159	LABEL, 1.0" X 1.5" PAPER	3
5	5600-01098-0	LABEL, PRE-PRINTED ESD ATTENTION	3
6	5652-01166-0	LABEL, PAPER, 2.0" X 4.0"	3 (NOTE 6)
7	6200-01211-0	ESD TAPE, 3/4" WIDE	1.0'
8	6256-01125-0	ESD PAD 335mm X 305mm	2
9	6256-01124-0	ESD PAD 335mm X 225mm	2
10	6256-01126-0	ESD PAD 255mm X 225mm	2
11	6256-01127-0	RIGHT ANGLE CLIP	4
12	6256-01671-0	SHIPPING BOX 350*320*290 WITH MPS LOGO	1

ITEM NUMBERS REFER TO 95000050121 BOM. ITEMS ABOVE ARE FOR REFERENCE ONLY, REFER TO APPROPRIATE BOM FOR COMPLETE LIST OF PARTS

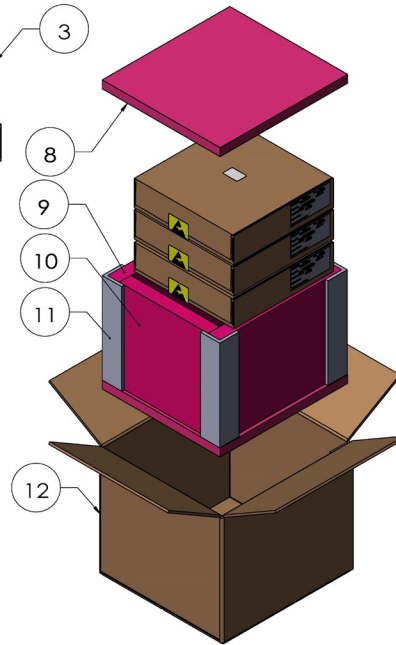
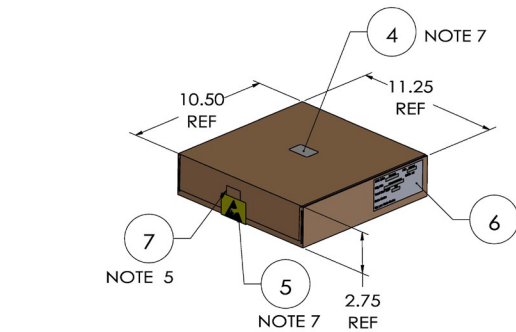
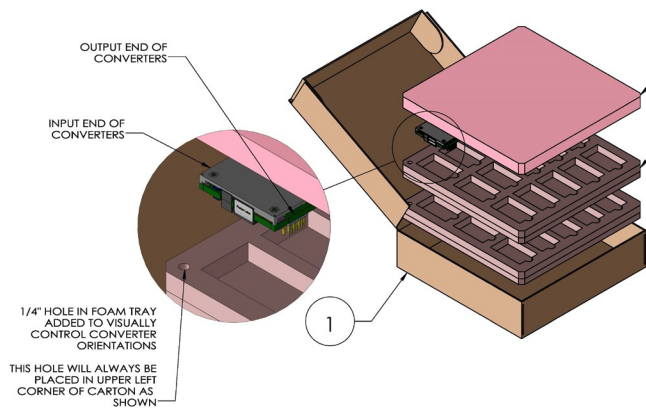
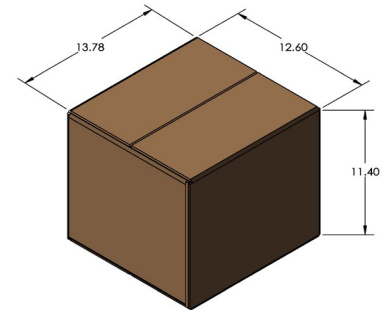

NOTES:

1. THIS DOCUMENT DEFINES THE GENERAL PACKING RULES FOR APPLICABLE SHIPPING KIT. INFORMATION FOR SEALING AND MARKING IS NOT PART OF THIS DOCUMENT.
2. REFER TO SHIPPING KIT BOM DETAILS.
3. INSERT UNITS INTO FOAM POCKETS IN TRAYS APPROX AS SHOWN
4. EACH FOAM TRAY (ITEM 3) CONTAINS 15 UNITS. EACH BOX (ITEM 1) CONTAINS 30 UNITS. IN FULL CARTON ITEM 12 QUANTITIES, 3 BOXES (ITEM 1) EQUAL A TOTAL OF 90 UNITS.
5. IF SHIPPING QTY IS 30PCS, PLEASE ALSO USE ITEM 12 TO MAKE THE PACKAGE TWO EMPTY BOX (ITEM 1) PUT ON THE BOX (ITEM 1) WITH PRODUCTS).
6. FRONT FLAP SHALL BE SEALED WITH ESD TAPE SPECIFIED OR EQUIVALENT AFTER THE BOX IS CLOSED.
7. LABEL (ITEM 6) USED FOR MFR OVERPACK CARTON
8. APPLY ESD LABEL (ITEM 5) OVER TAPE USED TO SEAL BOX AND APPLY IDENTIFICATION LABEL (ITEM 4) APPROX AS SHOWN.
9. PAD (ITEM 2) MAY, AT MFR'S OPTION, BE EXCHANGED FOR THINNER PAD IF FOAM STACKUP EXCEEDS CARTON HEIGHT BY $>1/8"$ OR ADDITIONAL PAD MAY BE ADDED IF STACKUP IS BELOW INSIDE CARTON HEIGHT BY $>1/8"$. ALTERNATE PADS: 1/4" THK=2300216, 3/8" THK=2300218, 1/2" THK=2300219, 3/4" THK=2300221

MPQ = 30

TECHNICAL NOTES & APPLICATIONS OVERVIEW

Power Management Overview and PMBus Interface (Applicable Models)

A wide range of parameters can be read and configured by the system/host by using PMBus™ digital communications.

Each module is provided pre-configured for a wide range operation. Refer to the [PMBus™ Interface](#) section for details.

SMBAlert# Hardware Signal (Applicable Models)

[SMBAlert#](#) signal offers an alternate method for system/host notification that a fault or Warning has been detected (mirrors the STATUS_X fault/warn register bits) within the module and is useful in applications requiring real time fault notification independent or in addition to reading PMBus™ STATUS_X register fault bits which may not be read by system/host frequently enough to detect that a fault/warning bit flag was set.

Internally driven low <0.4Vdc indicates a Vout, Iout, Vin, Temperature, or PowerGood fault/warning has been detected and remains low until the fault/warning stimulus has been removed and the system/host clears the individual bit flag or issues "CLEAR_FAULTS" command.

Drive high, >2.4Vdc to indicate no fault conditions within power module are detected.

Soft-start Power Up

The default rise time of the ramp up is 30ms. When starting by applying input voltage the control circuit boot-up time adds an additional 10ms delay. The soft-start power up of the module can be reconfigured using the PMBus interface.

Output Over Voltage Protection (OVP)

Both OVP limit and response can be configured via PMBus command (See PMBus Command 40h VOUT_OV_FAULT_LIMIT [for details](#)). The default output OVP limit is set to 20% above nominal output voltage and responds by immediately shutdown of main output and occur, output is latch, to rectify the fault, need to restart enable or Vin.

Over Current Protection (OCP, Current limit)

The module includes current limiting circuitry for protection at continuous over load. The default setting for the product is latch mode. The current limit can be configured by PMBus command 0x46, IOUT_OC_FAULT_LIMIT, to be greater than the IOUT_OC_WARN_LIMIT (PMBus Command 0x4A). The maximum value that the current limit could be set is 40A.

Power Good

The module provides [Power Good](#) (PG) flag in the STATUS_WORD register that indicates the output voltage is within a specified tolerance of its target level and no fault condition exists. The Power Good pin default logic is negative and it can be configured by MFR_PGOOD_POLARITY.

CAUTION: This converter is not internally fused. To avoid danger to persons or equipment and to retain safety certification, the user must connect an external fast-blow input fuse as listed in the specifications. Be sure that the PC board pad area and etch size are adequate to provide enough current so that the fuse will blow with an overload.

Start Up Considerations

When power is first applied to the DC-DC converter, there is some risk of startup difficulties if you do not have both low AC and DC impedance and adequate regulation of the input source. Make sure that your source supply does not allow

the instantaneous input voltage to go below the minimum voltage at all times. Use a moderate size capacitor very close to the input terminals. You may need two or more parallel capacitors. A larger electrolytic or ceramic cap supplies the surge current and a smaller parallel low-ESR ceramic cap gives low AC impedance.

Remember that the input current is carried both by the wiring and the ground plane return. Make sure the ground plane uses adequate thickness copper. Run additional bus wire if necessary.

Input Fusing

Certain applications and/or safety agencies may require fuses at the inputs of power conversion components. Fuses should also be used when there is the possibility of sustained input voltage reversal which is not current-limited. For greatest safety, we recommend a fast blow fuse installed in the ungrounded input supply line.

Input Under-Voltage Shutdown and Start-Up Threshold

Converters will not begin to fully regulate until the rising input voltage exceeds and remains at the Start-Up Threshold Voltage (see Specifications). Once operating, converters will not turn off until the input voltage drops below the Under-Voltage Shutdown Limit. Subsequent restart will not occur until the input voltage rises again above the Start-Up Threshold. This built-in hysteresis prevents any unstable/on/off operation at a single input voltage. The over/under-voltage fault level and fault response and hysteresis can be configured via the PMBus interface. See commands 0x55 (VIN_OV_FAULT_LIMIT) and 0x59 (VIN_UV_FAULT_LIMIT) in the PMBus command list for additional details

Start-Up Time

Turn-on time (see Specifications) is the time interval between the point when the rising input voltage crosses the Start-Up Threshold and the output voltage rises to within 10% of regulation point.

These converters include a soft start circuit to control Vout ramp time, thereby limiting the input inrush current.

The On/Off Remote Control interval from On command to Vout (final ±10%) assumes that the converter already has its input voltage stabilized above the Start-Up Threshold before the On command. The interval is measured from the On command until the output enters and remains within its specified accuracy band. See PMBus command 0x60 (TON_DELAY) for additional configuration [details](#)

Recommended Input Filtering

The user must assure that the input source has low AC impedance to provide dynamic stability and that the input supply has little or no inductive content, including long distributed wiring to a remote power supply. The converter will operate with no additional external capacitance if these conditions are met.

For best performance, we recommend installing a low-ESR capacitor immediately adjacent to the converter's input terminals. The capacitor should be a ceramic type such as the Murata GRM32 series or a polymer type. More input bulk capacitance may be added in parallel (either electrolytic or tantalum) if needed.

Recommended Output Filtering

This series need minimum polymer capacitor to keep loop stabilization. However, the user may install external output capacitance to further improve ripple or for improved dynamic response, however low-ESR ceramic (Murata GRM32 series) or polymer capacitors must be used and mounted close to the converter using only as much capacitance as required to achieve your ripple and noise objectives.

Excessive capacitance can make step load recovery sluggish or introduce instability. Never exceed the maximum rated output capacitance listed in the specifications.

Input Ripple Current and Output Noise

All models in this converter series are tested and specified for input reflected ripple current and output noise using designated external input/output components, circuits and layout as shown in the figures below. The Cbus and Lbus components simulate a typical DC voltage bus.

Minimum Output Loading Requirements

All models regulate within specification and are stable under no load to full load conditions.

Thermal Shutdown (OTP)

This series includes thermal sense and shutdown circuitry that protects itself from overtemperature conditions. Upon detection of overtemperature condition defined by PMBus command 0x4F "OT_FAULT_LIMIT", the module enters OTP and shutdown. Once the temperature falls below restart threshold, as defined in PMBus command list, (OT_FAULT_LIMIT, 0x4F and MFR_OT_FAULT_HYS, 0xEA), the module automatically restarts. OTP fault limit and recovery hysteresis are configurable via [PMBus](#).

CAUTION: If you operate too close to the thermal limits, the converter might shutdown suddenly without warning. Ensure to thoroughly test your application to avoid unplanned thermal shutdown.

Temperature Derating Curves

The graphs in this data sheet illustrate typical operation under a variety of conditions. The Derating curves show the maximum continuous ambient air temperature and decreasing maximum output current which is acceptable under increasing forced airflow measured in Linear Feet per Minute ("LFM"). Note that these are AVERAGE measurements. The converter will accept brief increases in current or reduced airflow as long as the average is not exceeded.

Note that the temperatures are of the ambient airflow, not the converter itself which is obviously running at higher temperature than the outside air. Also note that "natural convection" is defined as very low flow rates which are not using fan-forced airflow. Depending on the application, "natural convection" is usually about 30-65 LFM but is not equal to still air (0 LFM).

Murata Power Solutions makes Characterization measurements in a closed cycle wind tunnel with calibrated airflow. We use both thermocouples and an infrared camera system to observe thermal performance. As a practical matter, it is quite difficult to insert an anemometer to precisely measure airflow in most applications. Sometimes it is possible to estimate the effective airflow if you thoroughly understand the enclosure geometry, entry/exit orifice areas and the fan flow rate specifications.

CAUTION: If you exceed these Derating guidelines, the converter may have an unplanned Over Temperature shut down. Also, these graphs are all collected near Sea Level altitude. Be sure to reduce the derating for higher altitude.

Output Short Circuit Condition

The short circuit condition is an extension of the "Current Limiting" condition. When the monitored peak current signal reaches a certain range, the PWM controller's outputs are shut off thereby turning the converter "off." This is followed by an extended time out period. This period can vary depending on other conditions such as the input voltage level. Following this time out period, the PWM controller will attempt to re-start the converter by initiating a "normal start cycle" which includes soft start. If the "fault condition" persists, another "hiccup" cycle is initiated.

This "cycle" can and will continue indefinitely until such time as the "fault condition" is removed, at which time the converter will resume "normal operation." Operating in the "hiccup" mode during a fault condition is advantageous in that average input and output power levels are held low preventing excessive internal increases in temperature.

Remote On/Off Control

The MPQ series modules are equipped with an [On/Off control pin](#) (internal pull up, TTL open-collector and/or CMOS open-drain compatible) and is configurable via PMBus interface. Output is enabled when the On/Off is grounded or brought

to within a low voltage (see specifications) with respect to -Vin. The device is off (disabled) when the On/Off is left open or is pulled high to +13.5Vdc with respect to -Vin. The On/Off function allows the module to be turned on/off by an external device switch.

The restart delay for this module to turn On/Off by the On/Off control pin is 200ms.

On/Off can be configured by PMBus command [0xDD](#) (MFR_PRIMARY_ON_OFF_CONFIG); default configuration does not ignore the control pin and therefore requires the On/Off control pin to be asserted to start the unit.

On/Off status is dependent on On/Off control and OPERATION (PMBus command) status; both must be ON to turn MPQ on; if one of them is OFF, unit will be turned off.

Output Capacitive Load

These converters require external minimum capacitance added to achieve rated specifications. Users should consider adding capacitance to reduce switching noise and/or to handle spike current load steps. Install only enough capacitance to achieve noise objectives. Excess external capacitance may cause degraded transient response and possible oscillation or instability.

Remote Sense Input

Use the [Sense inputs](#) with caution. Sense is normally connected at the load. Sense inputs compensate for output voltage inaccuracy delivered at the load. This is done by correcting IR voltage drops along the output wiring and the current carrying capacity of PC board etches. This output drop (the difference between Sense and Vout when measured at the converter) should not exceed 0.5V. Consider using heavier wire if this drop is excessive. Sense inputs also improve the stability of the converter and load system by optimizing the control loop phase margin.

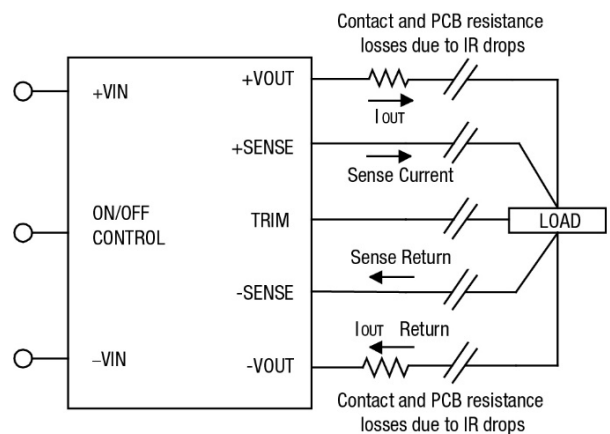

Remote Sense Circuit Configuration

Note: The Sense input and power Vout lines are internally connected through low value resistors to their respective polarities so that the converter can operate without external connection to the Sense. Nevertheless, if the Sense function is not used for remote regulation, the user should connect +Sense to +Vout and –Sense to –Vout at the converter pins.

The remote Sense lines carry very little current. They are also capacitively coupled to the output lines and therefore are in the feedback control loop to regulate and stabilize the output. As such, they are not low impedance inputs and must be treated with care in PC board layouts. Sense lines on the PCB should run adjacent to DC signals, preferably Ground. In cables and discrete wiring, use twisted pair, shielded tubing or similar techniques.

Any long, distributed wiring and/or significant inductance introduced into the Sense control loop can adversely affect overall system stability. If in doubt, test your applications by observing the converter’s output transient response during step loads. There should not be any appreciable ringing or oscillation. You may also adjust the output trim slightly to compensate for voltage loss in any external filter elements. Do not exceed maximum power ratings.

Please observe Sense inputs tolerance to avoid improper operation:

$$[Vout(+)-Vout(-)] - [Sense(+)-Sense(-)] \leq 10\% \text{ of } Vout$$

Output overvoltage protection is monitored at the output voltage pin, not the Sense pin. Therefore, excessive voltage differences between Vout and Sense together with trim adjustment of the output can cause the overvoltage protection circuit to activate and shut down the output.

Power derating of the converter is based on the combination of maximum output current and the highest output voltage. Therefore, the designer must ensure:

$$(Vout \text{ at pins}) \times (Iout) \leq (\text{Max. rated output power})$$

Soldering Guidelines

Murata Power Solutions recommends the specifications below when installing these converters. These specifications vary depending on the solder type.

Exceeding these specifications may cause damage to the product. Be cautious when there is high atmospheric humidity. We strongly recommend a mild pre-bake (100° C for 30 minutes). Your production environment may differ; therefore, please thoroughly review these guidelines with your process engineers.

Wave Solder Operation for Through-Hole Mounted Products (THMT)	
For Sn/Ag/Cu based solders:	
Maximum Preheat Temperature	115
Maximum Pot Temperature	270
Maximum Solder Dwell Time	7 seconds
For Sn/Pb based solders:	
Maximum Preheat Temperature	105
Maximum Pot Temperature	250
Maximum Solder Dwell Time	6 seconds

Trimming the Output Voltage

The Trim input pin is used to adjust the output voltage over the rated trim range (please refer to the Specifications). As illustrated in the trim equations and circuit diagrams below, trim adjustments use a single fixed resistor connected between the Trim input and either Vout Sense pin. Trimming resistors should have a low temperature coefficient (± 100 ppm/deg.C or less) and be mounted close to

the converter keeping leads short. If the trim function is not used, leave the trim unconnected, the converter will default to its specified output voltage accuracy.

Caution:

- Avoid activating shutdown protection (OVP, OCP, OTP) by ensuring the output voltage or output power is not exceeded when setting the output voltage trim.
- Keep the trim external connections as short as possible to avoid excessive noise that might otherwise cause instability or oscillation using shielding if needed.

Trim Equations

Trim Up: Connect Trim (Pin #J6) to +Vout Sense (Pin #J7)

$$Rt \text{ up}(k\Omega) = 1 * Vonom * (1 + \Delta) / (1.225 * \Delta) - 1 / \Delta - 2$$

$$\Delta = (Vonom - Vo) / Vonom$$

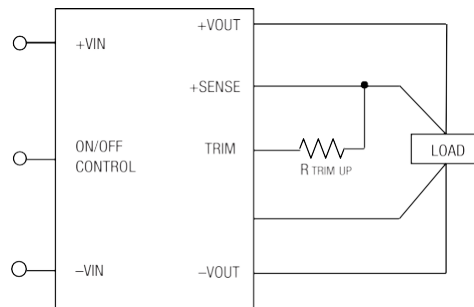

Trim Down: Connect Trim (Pin #J6) to -Vout Sense (Pin #J5)

$$Rt \text{ down}(k\Omega) = 1 / ((Vonom - Vo) / Vonom) - 2$$

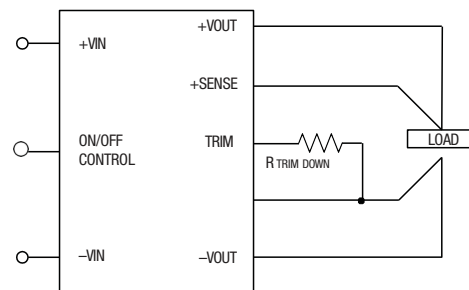

NOTE: Adjustment accuracy is subject to resistor tolerances and factory-adjusted output accuracy. Mount trim resistor close to converter. Use short leads.

Emissions Performance

Murata Power Solutions measures its products for conducted emissions against the EN 55022 and CISPR 22 standards. Passive resistance loads are employed and the output is set to the maximum voltage. If you set up your own emissions testing, make sure the output load is rated at continuous power while doing the tests.

The recommended external input and output capacitors (if required) are included. Please refer to the fundamental switching frequency. All of this information is listed in the Product Specifications. An external discrete filter is installed and the circuit diagram is shown below.

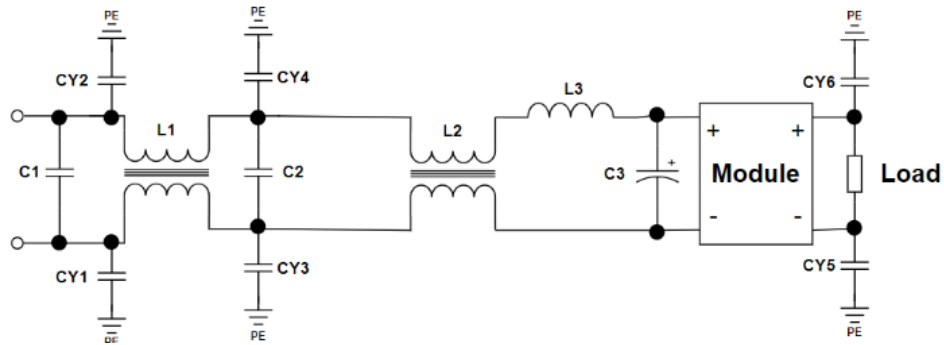

[1] Conducted Emissions Parts List

Reference	Description
C1	4.7uF*4
C2	10uF*2+4.7uF
C3	10uF*2+4.7uF+220uF
CY1/CY2	22nF +4.7nF
CY3/CY4	22nF +2.2nF
CY5/CY6	4.7nF
L1	3mH
L2	1.4mH
L3	22uH

[2] Conducted Emissions Test Equipment Used

Hewlett Packard HP8594L Spectrum Analyzer – S/N 3827A00153

2Line V-networks LS1-15V 50Ω/50Uh Line Impedance Stabilization Network

3] Conducted Emissions Performance

Figure 16. CE-L, Class A

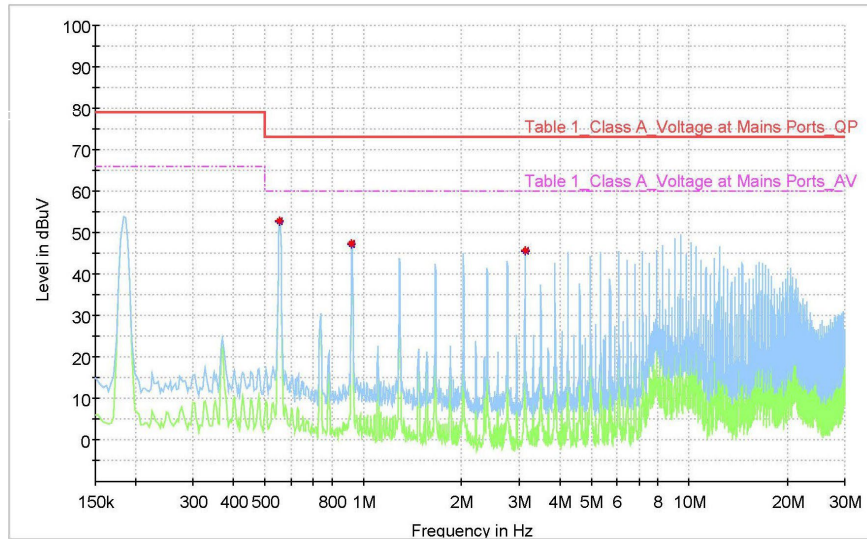

Frequency (MHz)	MaxPeak (dBuV)	Average (dBuV)	Limit (dBuV)	Margin (dB)	Meas. Time (ms)	Bandwidth (kHz)	Line	Corr. (dB)
0.552000	52.77	—	73.00	20.23	—	—	L3	10.2
0.552000	—	52.57	60.00	7.43	—	—	L3	10.2
0.921000	47.36	—	73.00	25.64	—	—	L3	10.2
0.921000	—	47.11	60.00	12.89	—	—	L3	10.2
3.135000	—	45.51	60.00	14.49	—	—	L3	10.3
3.135000	45.76	—	73.00	27.24	—	—	L3	10.3

Figure 17. CE-N, Class A

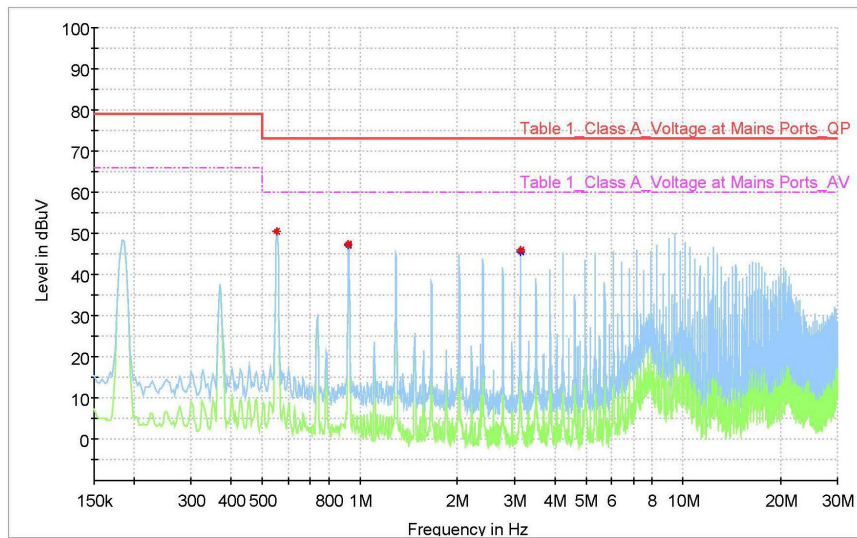

Frequency (MHz)	MaxPeak (dBuV)	Average (dBuV)	Limit (dBuV)	Margin (dB)	Meas. Time (ms)	Bandwidth (kHz)	Line	Corr. (dB)
0.552000	50.59	—	73.00	22.41	—	—	N	10.3
0.552000	—	50.43	60.00	9.57	—	—	N	10.3
0.921000	47.39	—	73.00	25.61	—	—	N	10.3
0.921000	—	47.19	60.00	12.81	—	—	N	10.3
3.135000	—	45.47	60.00	14.53	—	—	N	10.3
3.135000	45.96	—	73.00	27.04	—	—	N	10.3

[4] Layout Recommendations

Most applications can use the filtering which is already installed inside the converter or with the addition of the recommended external capacitors. For greater emissions suppression, consider additional filter components and/or shielding. Emissions performance will depend on the user's PC board layout, the chassis shielding environment and choice of external components. Since many factors affect both the amplitude and spectra of emissions, we recommend using an engineer who is experienced at emissions suppression.

PMBus™ Digital Communications Protocol

This module offers a PMBus digital interface that enables the user to configure many characteristics of the device operation as well as to monitor the input and output voltages, output current and device temperature. The module can be used with any standard two-wire I²C or SMBus host device.

A system controller (host device) can monitor a wide variety of parameters through the PMBus interface and detect fault conditions by monitoring the SMBALERT# pin, which will be asserted when any number of pre-configured fault or warning conditions occurs. The system controller can also continuously monitor any number of power conversion parameters including but not limited to the following:

- [1] Input voltage
- [2] Output voltage
- [3] Output current
- [4] Module temperature

Software Tools for Design and Production

For these modules, Murata-PS provides software for configuring and monitoring via the PMBus interface. For more information, please contact your local Murata-PS representative.

Standard PMBus™ Characteristics

- Complies with "Power Systems Management Protocol Specification Part 1 General Requirements Transport and Electrical requirements revision 1.2" & "Power Systems Management Protocol Specification Part 2 Command Language revision 1.2"
- Linear data format is used for all supported parameters unless noted
- Up to 400kHz I²C communications bus speed is supported
- SMBALERT## is supported
- PEC is supported
- Clock stretching is supported

PMBus™ Monitoring Accuracy

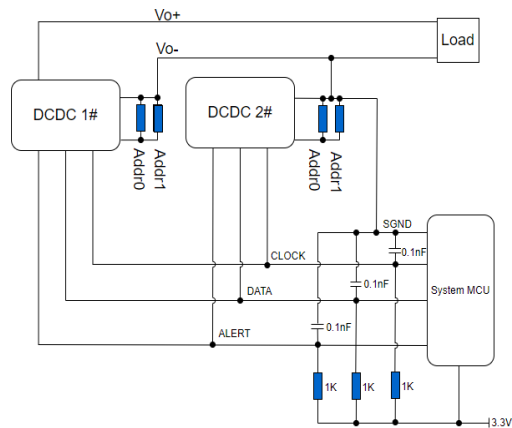

PMBus Addressing

This power module series offers three address configurations to support a wide range of applications. The address is set by externally connecting two resistors from each of the two address pins “Addr1” and “Addr0” to signal ground “Sig_Gnd” and forms two octal (0 to 7) digits, each pin setting one digit. The resistor value for each digit is defined according to the desired configuration.

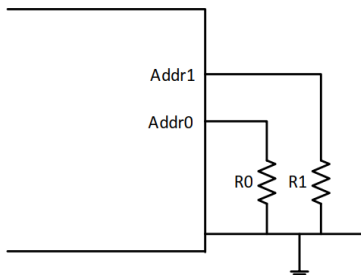

Addressing configuration 0 (default): If the calculated PMBus address is 0~12D, 40D, 44D, 45D or 55D, SA0 or SA1 lefts open, default PMBus address 127D is assigned instead.

$$\text{PMBus_Address} = 8x (\text{SA1 index}) + (\text{SA0 index})$$

Digit	Resistor Value R_{SA0}/R_{SA1} [kΩ]
0	10
1	15.4
2	23.7
3	36.5
4	54.9
5	84.5
6	130
7	200

Calculation: $\text{PMBus_Address} = 8x (\text{SA1 index}) + (\text{SA0 index})$

Addressing configuration 0 (default): If the calculated PMBus address is 0D, 11D, 12D, SA0 or SA1 lefts open, default PMBus address 119D is assigned instead.

$$\text{PMBus_Address} = 8x (\text{SA0 index}) + (\text{SA1 index})$$

Digit	Resistor Value R_{SA0}/R_{SA1} [kΩ]
0	10
1	22
2	33
3	47
4	68
5	100
6	150
7	220

Calculation: $\text{PMBus_Address} = 8x (\text{SA0 value}) + (\text{SA1 value})$

Addressing configuration 0 (default): If the calculated PMBus address is 0~12D, 40D, 44D, 45D or 55D, SA0 or SA1 lefts open, default PMBus address 88D is assigned instead.

$$\text{PMBus_Address} = 16x\text{Addr1} + \text{Addr0}$$

Digit	Resistor Value R_{SA0}/R_{SA1} [kΩ]
0	24.9
1	49.9
2	75
3	100
4	124
5	150
6	174
7	200

Calculation: $\text{PMBus_Address} = 16x \text{Addr1} + \text{Addr0}$

NOTE: Follow these steps to change the power module address configuration.

- 1) Select the desired address configuration via PMBus command 0xF5.
- 2) Save configuration to non-volatile user store memory by writing command 0x15 “STORE_USER_ALL”.
- 3) Recycle input power.

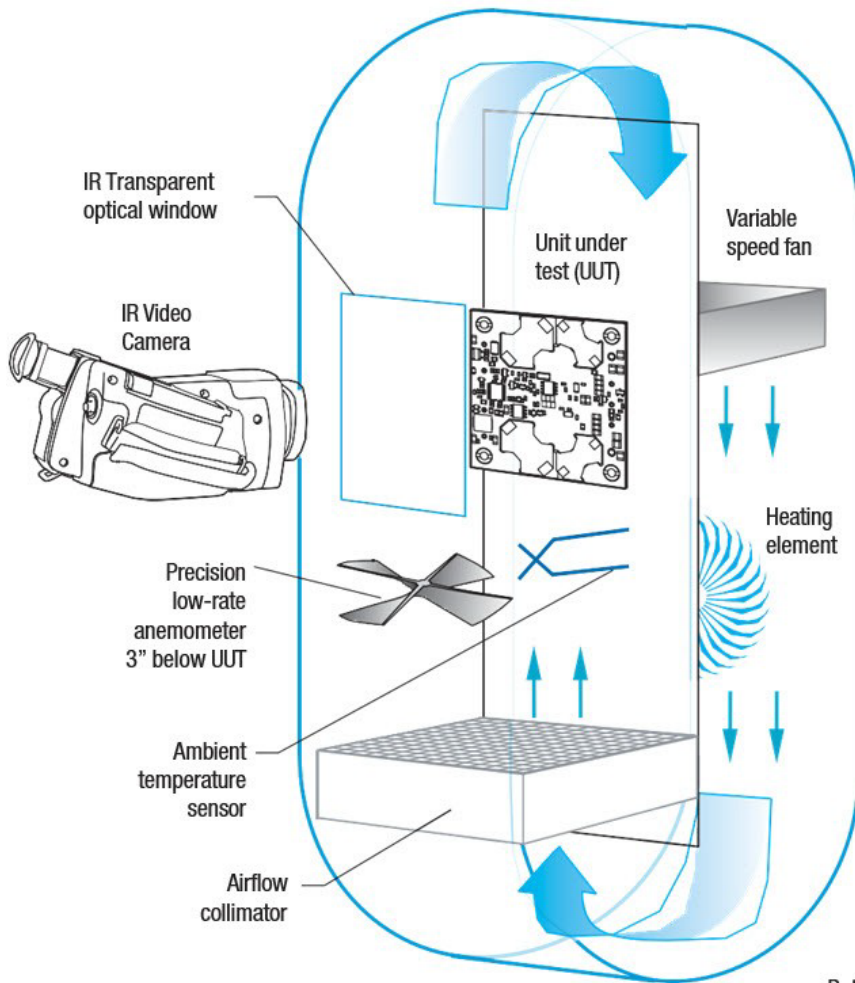

Vertical Wind Tunnel

Murata Power Solutions employs a custom-designed enclosed vertical wind tunnel, infrared video camera system and test instrumentation for accurate airflow and heat dissipation analysis of power products. The system includes a precision low flow-rate anemometer, variable speed fan, power supply input and load controls, temperature gauges and adjustable heating element.

The IR camera can watch thermal characteristics of the Unit Under Test (UUT) with both dynamic loads and static steady-state conditions. A special optical port is used which is transparent to infrared wavelengths. The computer files from the IR camera can be studied for later analysis.

Both through-hole and surface mount converters are soldered down to a host carrier board for realistic heat absorption and spreading. Both longitudinal and transverse airflow studies are possible by rotation of this carrier board since there are often significant differences in the heat dissipation in the two airflow directions. The combination of both adjustable airflow, adjustable ambient heat and adjustable Input/Output currents and voltages mean that a very wide range of measurement conditions can be studied.

The airflow collimator mixes the heat from the heating element to make uniform temperature distribution. The collimator also reduces the amount of turbulence adjacent to the UUT by restoring laminar airflow. Such turbulence can change the effective heat transfer characteristics and give false readings. Excess turbulence removes more heat from some surfaces and less heat from others, possibly causing uneven overheating.

Both sides of the UUT are studied since there are different thermal gradients on each side. The adjustable heating element and fan, built-in temperature gauges and no-contact IR camera mean that power supplies are tested in real-world conditions.

