

# UHF RFID Tag Data Sheet

## LXMS21ACMF-183



### 1. General descriptions

LXMS21ACMF-183 is an innovative RFID module designed to operate in electronic products/applications. It incorporates an industry standard IC.

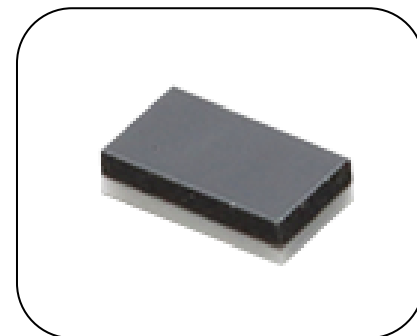

#### [Features]

- Small package design
- Reflow SMT compatible
- UHF band (865~928MHz)
- ISO18000-63 / EPC Global Gen2(v2) Compliant
- Size is 2.0 x 1.2 x 0.5mm
- Using impinj MonzaR6
- Read range:9m \*Reference
- RoHS compliant

### 2. Block diagram

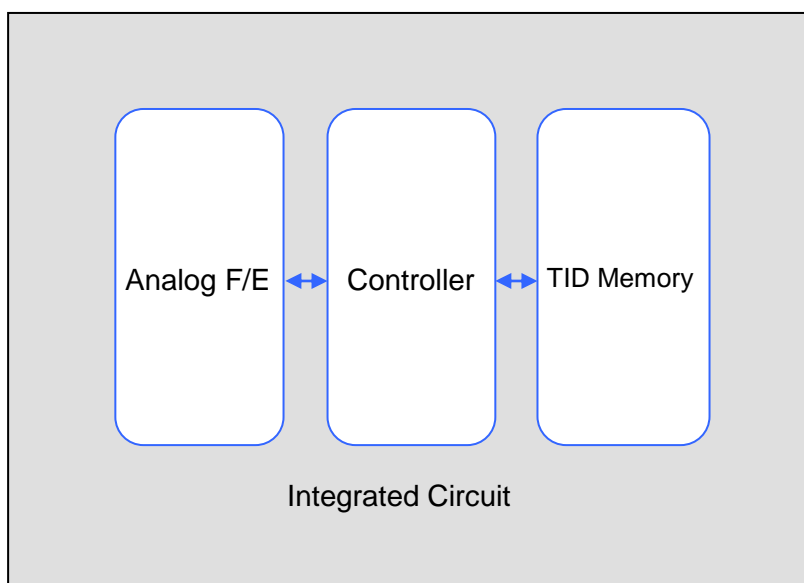
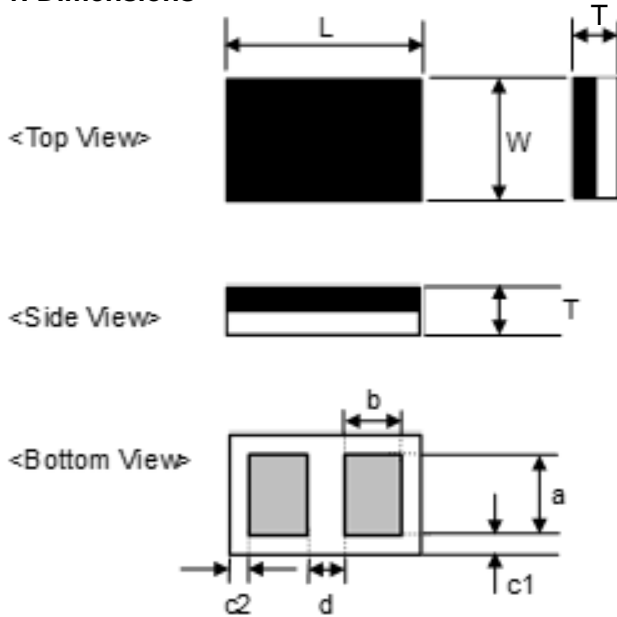

**Fig. 1 MAGICSTRAP®Block Diagram**

**All Rights Reserved, Copyright© Murata Manufacturing Co., Ltd.**  
< Specification is subject to change without notice >

**3. Mechanical information**

**3-1. Dimensions**



Unit : mm

Mark	Dimensions	Mark	Dimensions
L	2.00±0.15	b	0.6±0.1
W	1.2±0.15	c1	0.2±0.2
T	0.5MAX	c2	0.2±0.2
a	0.85±0.10	d	0.4±0.1

Fig. 2 MAGICSTRAP® Package Dimension

**3-2. Recommended land pattern**

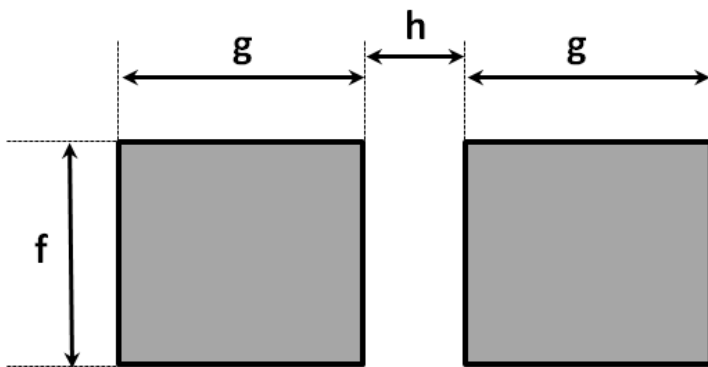

Unit : mm

Mark	Dimensions
f	0.90
g	1.00
h	0.40

Fig. 3 Land Pattern

#### **4. Electrical performance**

##### **4-1. Frequency range**

865 – 928MHz

##### **4-2. IC / Memory size**

IC	EPC	TID	USER
Impinj MonzaR6	96bit	96bits	N/A

#### **5. Absolute maximum ratings**

Symbol	Parameter	Min	Max	Unit
T <sub>stg</sub>	Storage temperature	-40	+85	°C
T <sub>a</sub>	Operating temperature	-40	+85	°C

**6. Reference antenna design on PCB**

**6-1. Top layer**

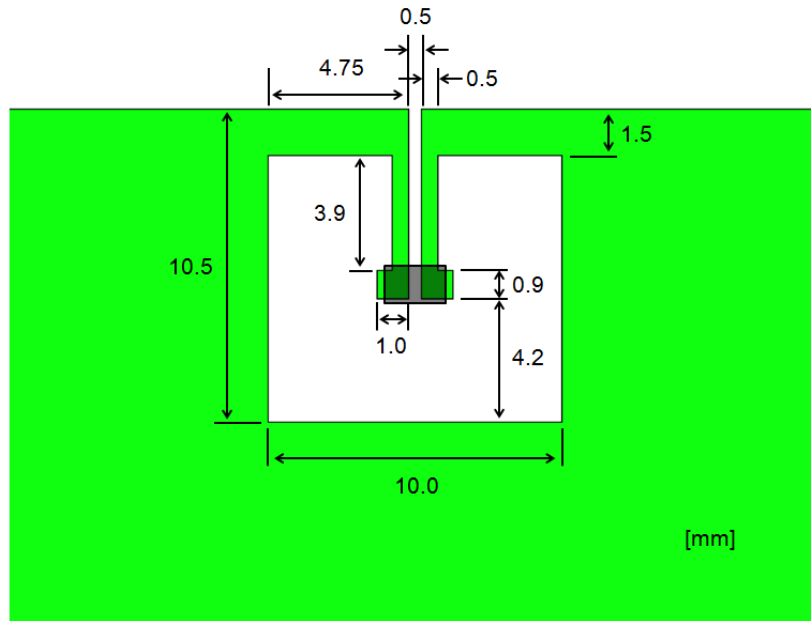

Mounting pattern (normal)  
Please conduct to PCB ground

**6-2. How to design layers below the mounting pattern**

Please remove all the copper pattern area from all layers of the PCB, if it is located under mounting pattern on surface layer.

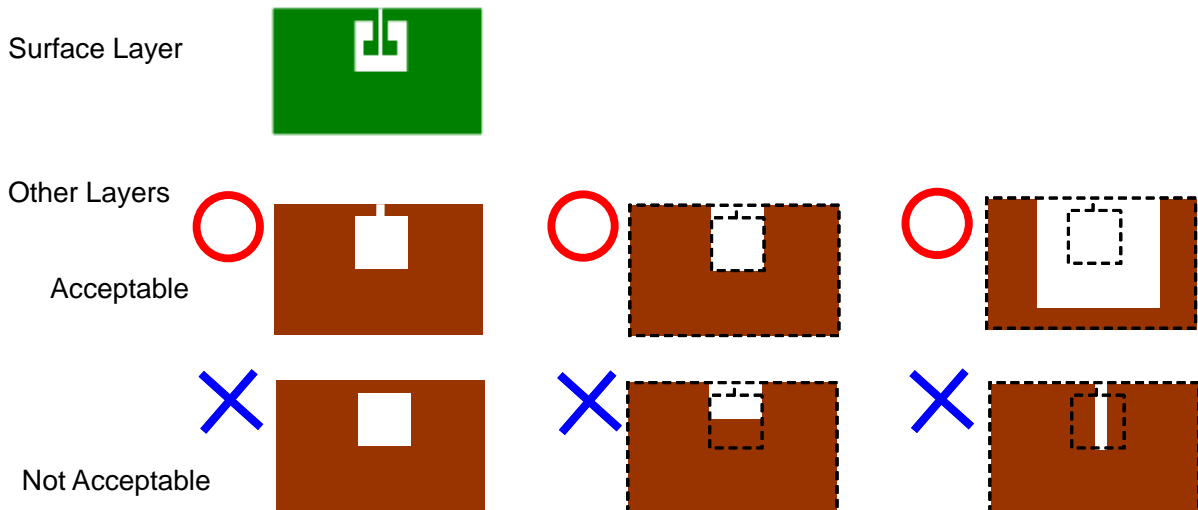

### 6-3 how to put via hole

Please put via holes as shown in the figure below. If there is no via hole in multi layered PCB, unnecessary inductance degrade performance.

#### 6-3-1 For normal pattern

The example of via hole layout

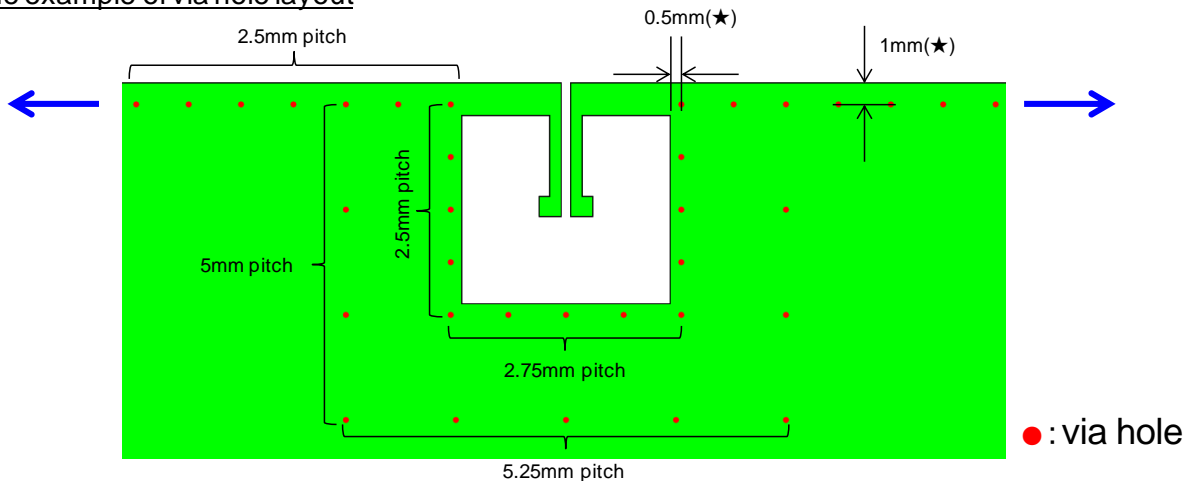

diameter: 0.3mm $\Phi$   
pitch : 2.5mm, 2.75mm (around pattern)  
5mm, 5.25 mm (other)

At the point of (★), The less value will get the less degradation.  
Also increasing the number of via holes will get PCB less degradation.  
At blue arrow direction, Please place the via holes to the edge of the board.  
(If there is a GND electrode on other layers)

#### 6-3-2 For small pattern

The example of via hole layout

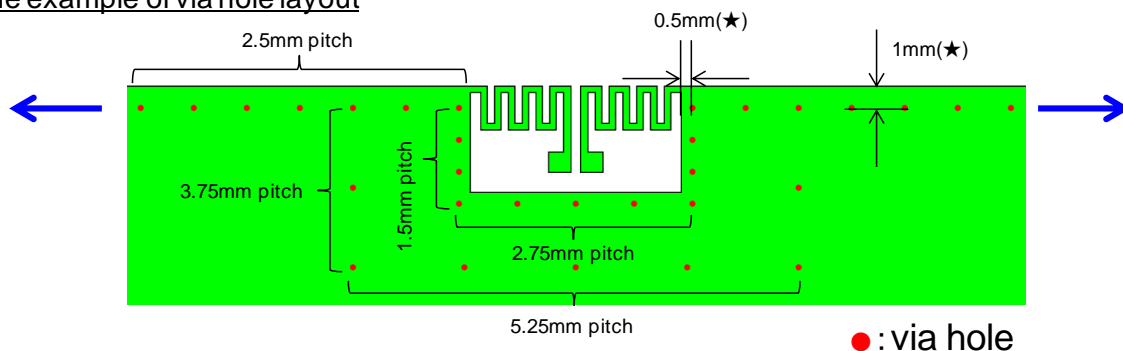

diameter: 0.3mm $\Phi$   
pitch : 1.5mm, 2.75mm (around pattern)  
3.75, 5.25 mm (other)

At the point of (★), The less value will get the less degradation.  
Also increasing the number of via holes will get PCB less degradation.  
At blue arrow direction, Please place the via holes to the edge of the board.  
(If there is a GND electrode on other layers)

**All Rights Reserved, Copyright© Murata Manufacturing Co., Ltd.**  
< Specification is subject to change without notice >

**6-4. Reading distance**

Max. 9.0meter (at 4wEIRP, with 15cm length of PCB ground)

The reading distance of MAGICSTRAP® onto PCB, depends on the length of PCB ground.

**technical information**

Reading distance is derived by the parameters of mounting pattern and length of PCB ground.

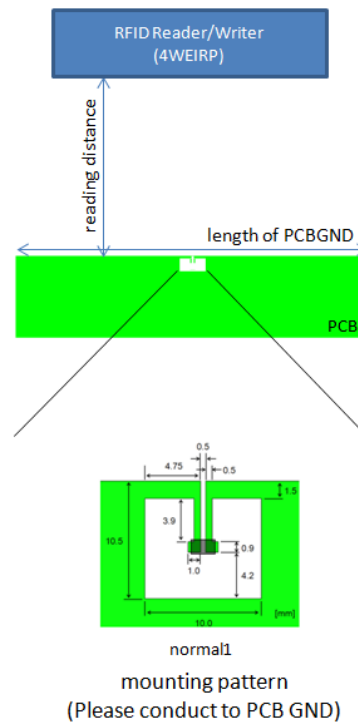
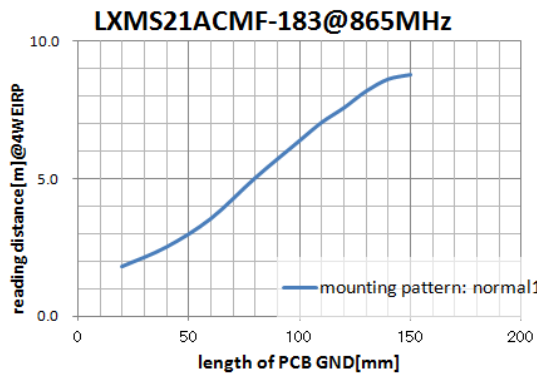
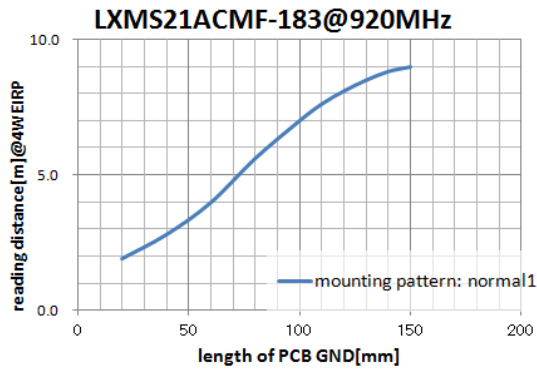

**6-5. Metal enclosure under printed circuit board:**

When the PCB is in close proximity to the metal enclosure, sensitivity is reduced. Removing material directly under the MAGICSTRAP® antenna pattern will greatly improve sensitivity.

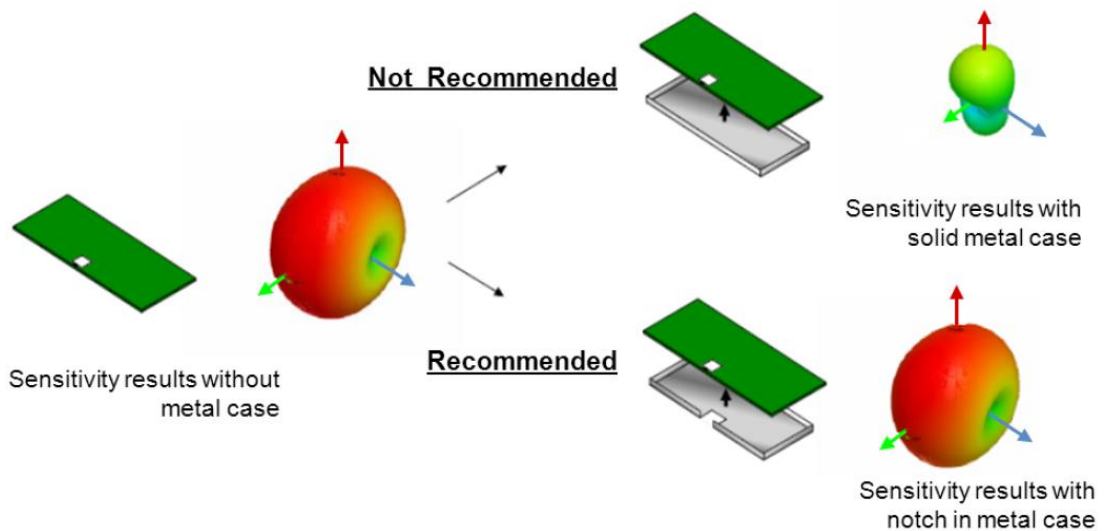

**6-6. Antenna location on PCB**

Important area of PCB ground is the edge part shown as “dark green” below. The mounting pattern should be located closest to the edge of the PCB. Variations of ideal design are also acceptable.

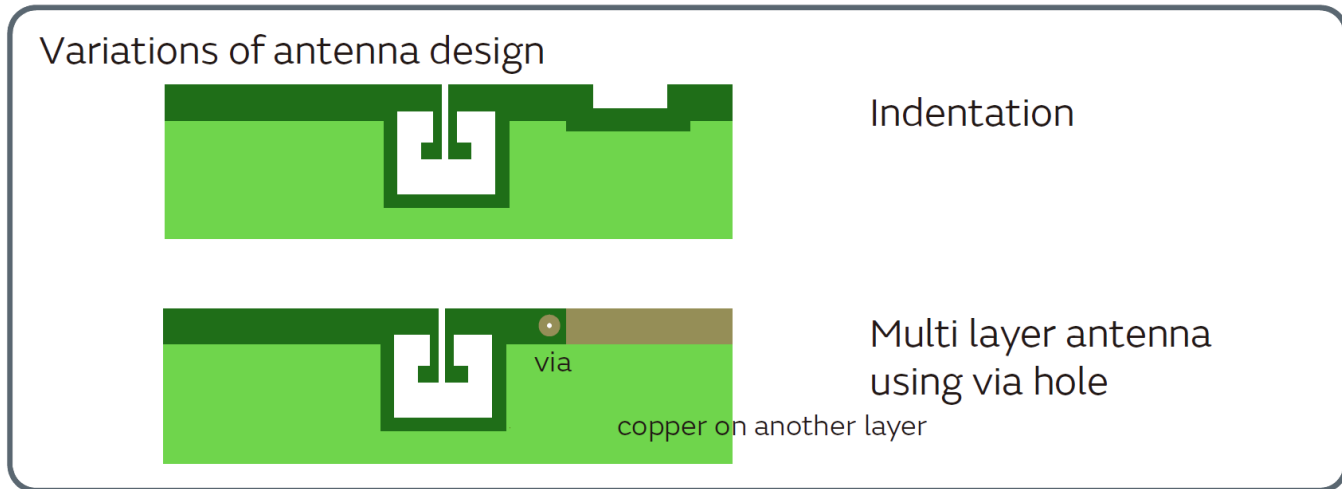
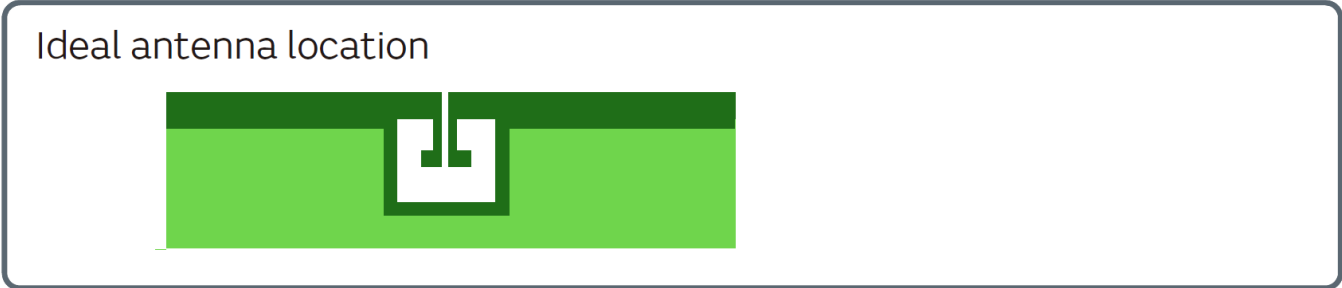

**6-7. Position of MAGICSTRAP® on PCB**

MAGICSTRAP® should be centered on the long side of the PCB to maximize read range. The following illustrates the relationship between “X” length and read range.

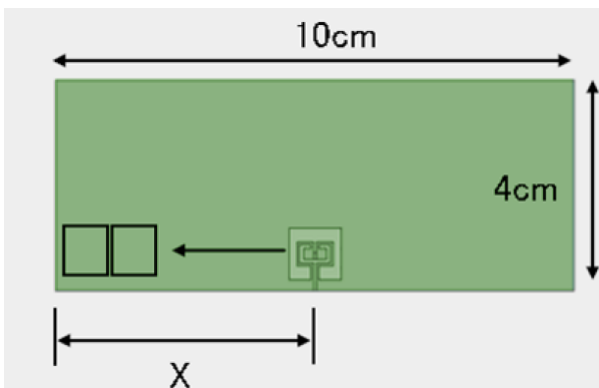

Length “X” (cm)	Read Range (m)
5	7
2	5
1	3.5

**All Rights Reserved, Copyright© Murata Manufacturing Co., Ltd.**  
 < Specification is subject to change without notice >

6-8. Soldering Conditions

Soldering is allowed up through 2 times.

Reflow soldering standard conditions(Example)

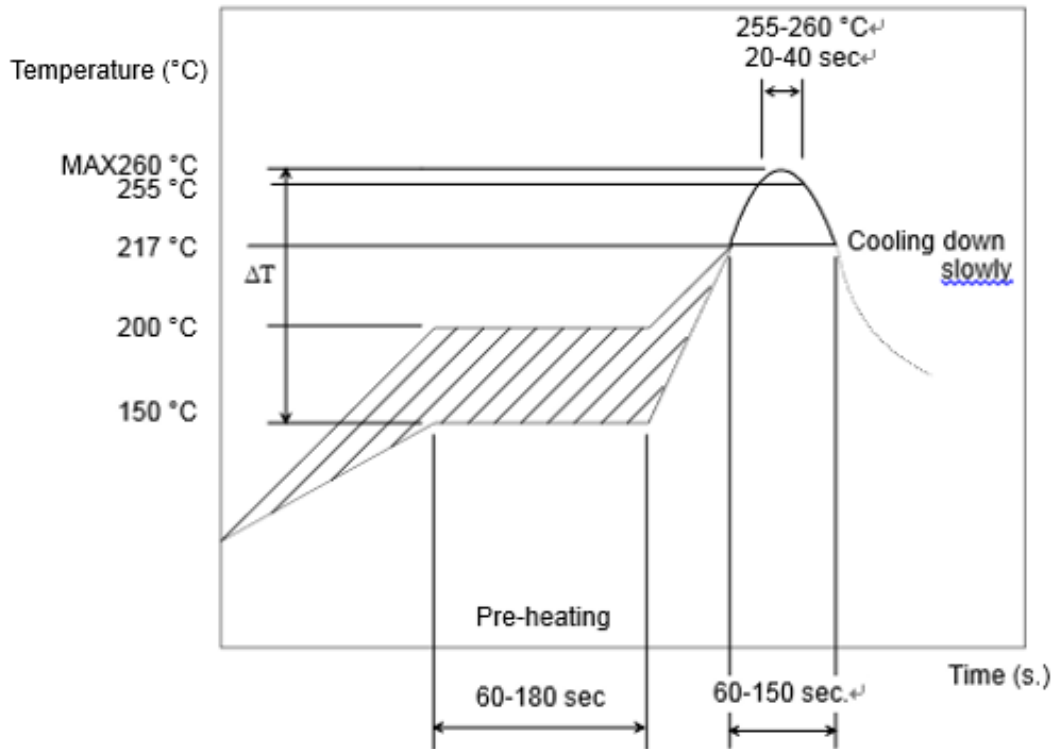



**7. Tape and Reel Packing**

**7-1. Dimensions of Tape**

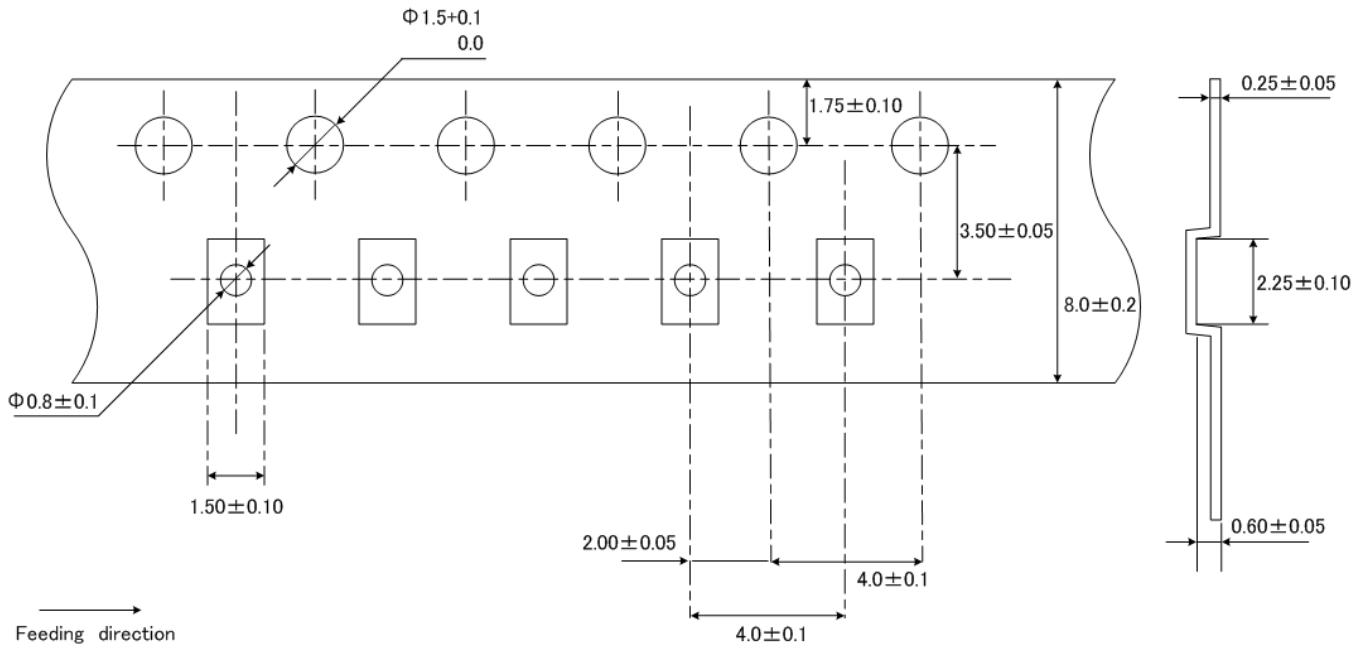

**7-2. Dimensions of Reel**

Unit: mm

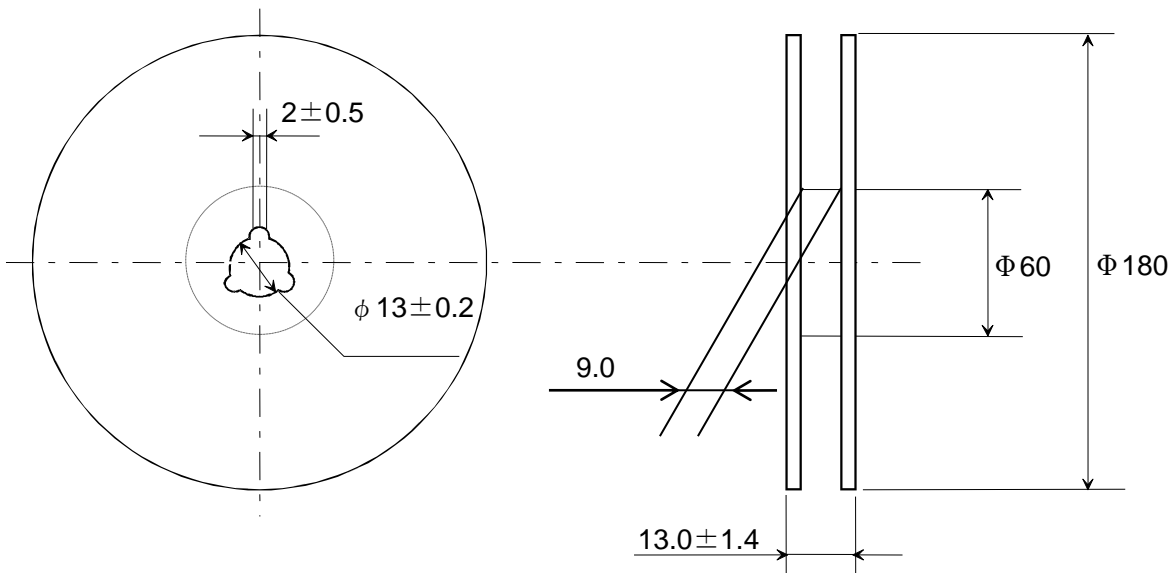

All Rights Reserved, Copyright© Murata Manufacturing Co., Ltd.  
< Specification is subject to change without notice >

7-3. Taping Diagrams

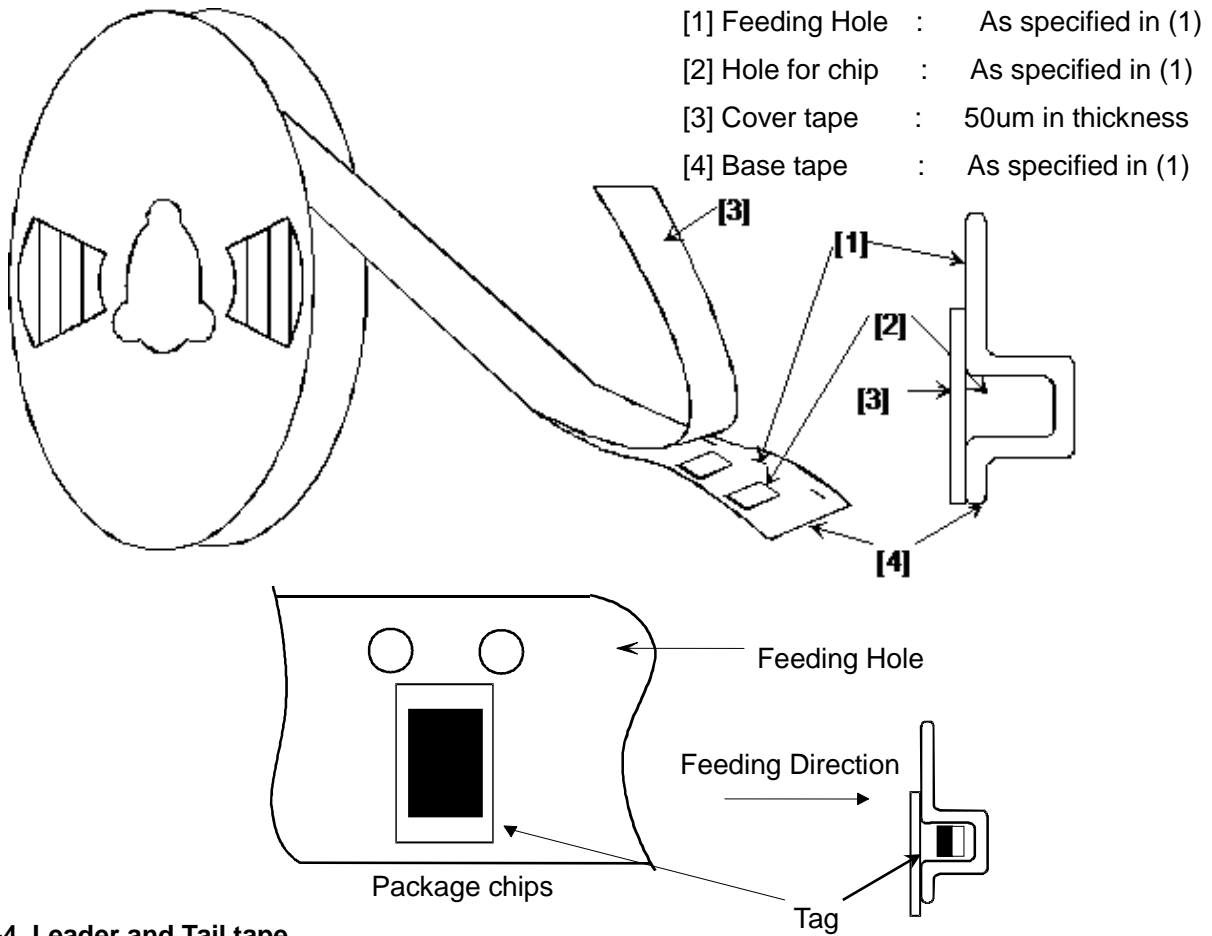

7-4. Leader and Tail tape

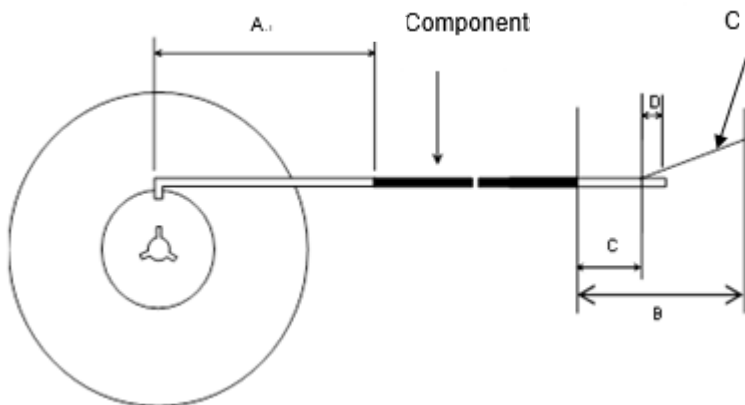

A	1160-1190 mm
B	400-500 mm
C	150-200 mm
D	20-40 mm

All Rights Reserved, Copyright© Murata Manufacturing Co., Ltd.  
 < Specification is subject to change without notice >

# UHF RFID Tag Data Sheet

## LXMS21ACMF-183

### 7-5. Taping direction

The tape for chips are wound clockwise, the feeding holes to the right side as the tape is pulled toward the user.

### 7-6. Quantity per reel

5,000 pcs

### 7-7. Minimum order quantity

5,000pcs

### 7-8. Material

Base tape: Plastic

Reel: Plastic

### 7-9. Peeling force

0.1~1.0 N in the direction of peeling as shown below.

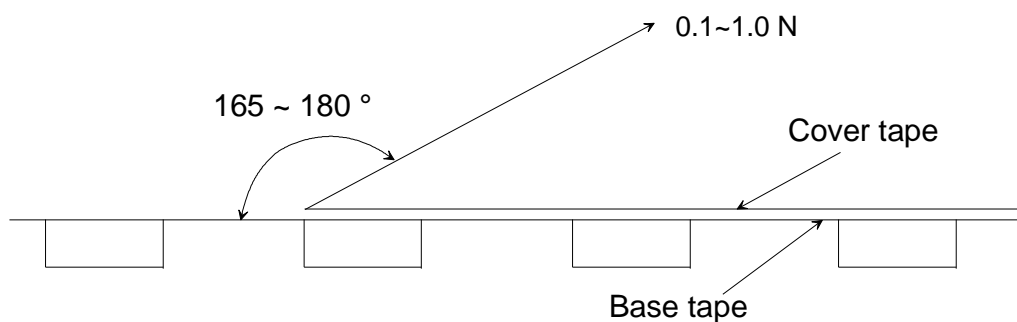

## 8. Contact window

URL : <http://www.murata.com/products/rfid>

Email : [magicstrap@murata.com](mailto:magicstrap@murata.com)

" MAGICSTRAP® " is the registered trademark of Murata Manufacturing. Co., Ltd.

For any inquiries/queries, please feel free to contact us.

**All Rights Reserved, Copyright© Murata Manufacturing Co., Ltd.**

< Specification is subject to change without notice >

## NOTICE

### 1. Storage Conditions:

To avoid damaging, be sure to observe the following points.

- Store products where the ambient temperature is 15 to 35 °C and humidity 45 to 75% RH.  
(Packing materials, In particular, may be deformed at the temperature over 40 °C.).
- Store products in non corrosive gas (Cl<sub>2</sub>, NH<sub>3</sub>, SO<sub>2</sub>, NO<sub>x</sub>, etc.).
- Stored products should be used within 6 months of receipt.
- This product is applicable to MSL1 (Based on IPC/JEDEC J-STD-020)

### 2. Handling Conditions:

Be careful in handling or transporting products because excessive stress or mechanical shock may break products.



#### Note:

Please make sure that your product has been evaluated and confirmed against your specifications when our product is applied to your product.

All the items and parameters in this product specification have been prescribed on the premise that our product is used for the purpose, under the condition and in the environment agreed upon between you and us. You are requested not to use our product deviating from such agreement.